



Interconnection Requirements

Document Number

IR-DG-001

Policy

INTERCONNECTION REQUIREMENTS FOR CUSTOMER-SITED DISTRIBUTED GENERATION

Effective Date

January 1, 2020

To ensure compliance, always refer to the latest version of this document posted on the LG&E and KU website: <https://lge-ku.com/residential/guides> or <https://lge-ku.com/business/guides>

SECTION 1 – INTRODUCTION / SCOPE

This document specifies the minimum requirements for safe and effective operation of any customer-sited distributed generation energy source that is electrically connected with the Louisville Gas & Electric and Kentucky Utilities (LG&E and KU) “Company” electric distribution system. Distributed generation (DG) is defined as a source of electric energy that is interconnected at either primary or secondary distribution voltage and is operated in parallel with the Area Electric Power System. DG energy sources include spinning generators, inverter-based generation such as solar, wind, and energy storage, and any other asset capable of sourcing energy. This document is intended for generation installations on the LG&E and KU distribution system (voltages up to 34.5 kV) and does not include larger installations that are connected to the bulk electric system or electric transmission system (69 kV and above). Installations that are directly connected to the transmission system, or those that generate power for resale must comply with additional LG&E and KU requirements as described below.

Generators connecting at transmission voltage levels (69 kV and above) or for wholesale business at any voltage level are under FERC jurisdiction and must submit an Interconnection Request to the ITO (Independent Transmission Operator) as required by the Small Generator Interconnection Procedures (SGIP), which is attachment N in the LG&E and KU Open Access Transmission Tariff (OATT). Generators connecting at distribution voltage levels and operating under retail tariffs are not under FERC jurisdiction and must comply with all State regulations, LG&E and KU requirements, and applicable codes and standards.

The minimum required protective relaying and/or safety devices and requirements specified in this document, are for protecting only LG&E and KU facilities and the equipment of other customers from damage or disruptions caused by a fault, overcurrent condition, malfunction or improper operation of the generation source. These requirements are also necessary to ensure the safety of utility workers and the public. Minimum protective relaying and interconnection requirements do not include additional relaying, protective or safety devices as may be required by industry and/or government codes and standards, equipment manufacturer requirements and prudent engineering design and practice to fully protect the customer’s generation source; those are the sole responsibility of such customer. Distributed generation installations are subject to being disconnected from the distribution system if the source substation line is opened for any reason. The installation of the generation equipment shall not cause any reduction in the quality of service to any LG&E and KU customers.

The practical limit for connection of generation to the LG&E and KU distribution system (operating at 34.5 kV or lower) is 1.5 MVA for typical feeders. Generation in excess of 1.5 MVA will be considered on a case by case basis. Generation of 5 MVA or greater may require a dedicated distribution feeder or a 69 kV or 138 kV connection and additional protection equipment. The need for a dedicated distribution feeder or a transmission connection will be determined by a LG&E and KU engineering evaluation.

SECTION 2 – DEFINITIONS

The following terms, as used in this document, shall have the meanings specified:

Advanced Inverter: A grid interactive Static Inverter with functions to allow for more elaborate monitoring and communication of the grid status, the ability to receive operation instructions from a centralized location, and the capability to make autonomous decisions to improve grid stability, support power quality, and provide ancillary services such as voltage regulation, power factor control and reactive power control.

Agreement: See “Interconnection Agreement”.

AHJ: Authority Having Jurisdiction, the organization, office, or individual responsible for enforcing the requirements of a code or standard or for approving equipment, materials, an installation, or a procedure.

ANSI: American National Standards Institute. See www.ansi.org.

Application: The standard form for applying to interconnect a generation facility with the LG&E and KU System also referred to as the “Interconnection Application”.

Backfeed: To energize any section of the LG&E and KU System from an electric source other than the normal utility source.

Backup Generator: An independent power generation source or sources located at a Customer’s facility installed for the sole purpose of supplying on-site generated power to selected loads upon failure or outage of the normal Utility source. A Backup Generator shall be understood to include Critical, Emergency and Standby Power Systems as defined in IEEE Std. 446 and the NEC.

Behind the Meter: A term used to describe a power generation application in which the generation facility is not directly interconnected to the LG&E and KU System but rather, to a Customer-owned electric system that is itself electrically connected to LG&E and KU System via a retail billing meter.

Bi-directional Meter: A retail billing meter having two separate metering registers, one to record electricity delivered to Customer and the other to record electricity received from Customer.

Business Day: Monday through Friday, excluding Federal and State holidays.

Clearance: Pertains to the holding of a section of line or piece of equipment out of service so that work may be safely performed. Clearance may only be issued by an administrative authority after appropriate lockout/tagout (LOTO) procedures have been followed.

Clearance Point: The physical location on a section of a power line or equipment that is to be visibly disconnected from all known power sources of power.

Closed Transition Transfer (CTT): The transfer of electrical load between two power sources (normally the Utility grid and Customer’s Generator) in which the power sources electrically synchronize and parallel for a period of time to transfer load between the power sources without interrupting power to the load. This is also referred to as a “make-before-break” Transfer Switch or Scheme. A CTT may be accomplished by either a Momentary Parallel Transition or a Smooth Parallel Transition.

Cogeneration Facility: Any facility that sequentially produces electricity, steam or forms of useful energy (e.g., heat) from the same fuel source and which are used for industrial, commercial, heating, or cooling purposes.

Continuous Parallel: A generation facility that electrically parallels with the LG&E and KU System for more than 15 seconds.

Customer: A LG&E and KU account holder or LG&E and KU “Customer of Record” that receives electric service from LG&E and KU and which may also generate electricity at the property receiving electric service. A Customer shall be understood to include any independent party or entity that either invests in, owns or operates the generating facility including without limitation its grantees, lessees or licensees.

Dedicated Utility Feeder: A Distribution System feeder placed into service with the sole purpose of serving a single Customer. A non-Dedicated utility feeder (sometimes referred to as a “Shared Feeder”) serves multiple Customers.

Disconnect Switch: A visible open disconnect device that Customer is required to install and maintain in accordance with the requirements set forth in this document. It will completely isolate a Customer's generating facility from the LG&E and KU System, including the Utility metering equipment located at the SES.

Distributed Energy Resource (DER): DER is a broad term that encompasses Distributed Generation (DG) and can also include other technologies such as demand response and energy efficiency. A DER is any source or consumer of electric energy that is connected to the distribution system, either behind the meter in/on the customer's premise, or directly on the utility's primary distribution system that contains some level of controllability. A DER includes both generators and energy storage technologies capable of exporting active power to the utility or other metered energy consumers. DER can also include controllable energy resources that can affect energy flows on the distribution system such as energy efficiency, demand response, direct load control, and others.

Distributed Generation (DG): Any type of electrical Generator, Static Inverter or generating facility interconnected with the LG&E and KU System that either (a) has the capability of being operated in electrical parallel with the LG&E and KU System, or (b) can feed a Customer load that can also be fed by the LG&E and KU System. A Distributed Generation facility is also referred to as a “Generating Facility” or “generating facility” in this document. DG is a subset of DER that only includes resources that can, or has the possibility to, generate electric power in parallel with the distribution system. DG does not include demand response or other controllable energy consumption.

Distribution System: The infrastructure constructed, maintained, and operated by LG&E and KU to deliver electric service at the distribution level (34.5 kV or less) to retail Customers. This is also referred to as the LG&E and KU System.

Electric Service: Service provided by LG&E and KU to Customer in accordance with all applicable LG&E and KU requirements, including but not necessarily limited to LG&E and KU Electric Service Handbooks, whereby electricity may be delivered by LG&E and KU to Customer, or electricity may be received by LG&E and KU from Customer.

The LG&E and KU Electric Service Handbooks are available at: <https://lge-ku.com/residential/guides> or <https://lge-ku.com/business/guides>

Energy Storage (ES or ESS): The capture of energy produced at one time for use at a later time. A device that stores energy with the potential to Backfeed.

Electric Supply/Purchase Agreement: An agreement, together with appendices, signed between LG&E and KU and Customer covering the terms and conditions under which electrical power is supplied to and/or purchased from LG&E and KU.

Fault Current: The level of current that can flow if a short circuit is applied to a voltage source.

FERC: Federal Energy Regulatory Commission.

Generating Facility: All or part of Customer’s electrical Generator(s) and or Energy Storage together with all protective, safety, and associated equipment and improvements associated with the interconnection to, or operation in conjunction with, the LG&E and KU System.

Generator: A Rotating Machine or Static Inverter used to produce electrical power.

Good Utility Practice: Any of the practices, methods, and acts engaged in or approved by a significant portion of the electric industry during the relevant time period, or any of the practices, methods, and acts which, in the exercise of reasonable judgment in light of the facts known at the time the decision was made, could have been expected to accomplish the desired result at a reasonable cost consistent with good business practices, reliability, safety, and expedition. Good Utility Practice is not intended to be limited to the optimum practice, method, or act to the exclusion of all others, but rather to be acceptable practices, methods, or acts generally accepted in the region.

IEEE: The Institute of Electrical and Electronic Engineers. See <http://www.ieee.org/index.html>.

Interconnection: The physical connection of Customer's generating facility with the LG&E and KU System.

Interconnection Agreement (also referred to as an "Agreement"): An agreement, together with appendices, signed between LG&E and KU and Customer, covering the terms and conditions governing the Interconnection and parallel operation of the generating facility with LG&E and KU.

Interconnection Application (refer to "Application"): An application form and all supplementary information specified and attached within this document.

Interconnection Generation Design Review Agreement: An agreement signed between LG&E and KU and Customer covering the terms for LG&E and KU to proceed with a detailed study (i.e. Interconnection Study) of the impact of Customer's DG on the LG&E and KU System.

Interconnection Requirements: The requirements set forth in this document and all additional requirements that are referenced in this document.

Interconnection Study (Study): A study or studies that may be undertaken by LG&E and KU (or an LG&E and KU designated third party) in response to its receipt of a completed Application for Interconnection and parallel operation with the LG&E and KU System. Interconnection studies may include, but are not limited to, Interconnection Feasibility Studies, System Impact Studies, and Facilities Studies.

Island: A condition in which a portion of a Utility electric power system is energized solely by one or more local electric power systems throughout the associated Point of Interconnection while that portion of the Utility electric power system is electrically separated from the rest of the Utility electric power system.

Kentucky Public Service Commission ("KY PSC" or "Commission"): The regulatory agency of the State of Kentucky having jurisdiction over public service corporations, including LG&E and KU, operating in Kentucky.

LG&E and KU: Louisville Gas & Electric and Kentucky Utilities.

LG&E and KU System (also referred to as the "Utility System"): Refers to LG&E and KU's' Electrical Transmission or Distribution System.

Main-Tie-Main (or Main-Tie-Tie-Main): A Transfer Scheme consisting of two main power source breakers and one or two tie breakers, designed such that electrical load can be transferred between two power sources.

Metering: The function related to measuring the transfer of electric power and/or energy.

Meter Disconnect: A lockable disconnect device or switch in accordance with OSHA LOTO requirements (i.e. OSHA 1910.147B), located within the same workspace as the production meter. Customer may be required to install and maintain this device in accordance with the requirements set forth in this document. It will completely isolate LG&E and KU required Generator Metering from any power source(s).

Microgrid: A group of interconnected loads and distributed energy resources with clearly defined electrical boundaries that acts as a single controllable entity with respect to the grid and can connect and disconnect from the grid to enable it to operate in both grid-connected or island mode.

Minimum Protective Devices, Relays, and Interconnection Requirements: The minimum required protective relaying and/or safety devices or requirements specified in this document, as may be revised from time to time, for the purpose of protecting only LG&E and KU and its other customer facilities from damage or disruptions caused by a fault, malfunction or improper operation of Customer's generating facility. Minimum Protective Relaying and Interconnection Requirements do not include relaying, protective or safety devices as may be required by industry and/or government codes and standards, equipment manufacturers and prudent engineering design and practice to fully protect Customer's generating facility or facilities; those are the sole responsibility of Customer.

Momentary Cessation: A protective mode when no current is injected into the grid by the inverter during low or high voltage conditions outside of its continuous operating range. This is accomplished by blocking the power electronics' firing commands and the inverter does not produce real or reactive current.

Momentary Parallel Transition: A form of Closed Transition Transfer in which the transfer of electrical load between two power sources occurs by electrically paralleling the power sources for a brief period of time in order to affect a rapid transfer of load between the power sources. A Momentary Parallel Transition is accomplished by paralleling the power sources for a period not to exceed ten cycles.

NEC: National Electric Code. See www.nfpa.org/nec.

NEMA: National Electrical Manufacturers Association. See <http://www.nema.org>.

NERC: North American Electric Reliability Corporation. See <http://www.nerc.com>.

Net Metering: A billing process whereby an electric "net metering" rate allows energy delivered by a Customer into the electric grid to be netted with energy received by Customer from the grid over the billing period. A Bi-directional meter is required to be installed in order to affect Net Metering.

Network: An AC power distribution system that includes automatic protective devices intended to isolate the network from faulted feeders while maintaining uninterrupted service to the Customer. Network service typically includes multiple parallel services fed via multiple parallel feeders and may include (if served via secondary voltage class) parallel step down transformation.

NFPA: National Fire Protection Association. See <http://www.nfpa.org>.

Non-Parallel Connection Agreement: An agreement, together with appendices, signed between LG&E and KU and Customer, covering the terms and conditions governing the non-parallel connection and operation of the generating facility with LG&E and KU.

Non-Wires Alternative (NWA): An electricity grid investment or project that uses non-traditional T&D solutions, such as distributed generation, energy storage, energy efficiency demand response, and grid software and controls, to defer or replace the need for specific equipment upgrades, such as T&D lines or transformers, by reducing load at a substation or circuit level.

NRTL: Nationally Recognized Testing Laboratory.

Operations Center: A Customer owned facility in which monitoring and/or control of the Generating Facility occurs. The Operations Center can be a combination of automatic and manual controlled/monitored devices (i.e. relays, generator controllers, switches, etc....) to ensure the reliability and safe operation of the generating facility. The operations center is generally manned 24-7 and shall be reachable via LG&E and KU.

Open Transition Transfer: The transfer of electrical load between two power sources (normally the Utility grid and Customer's Generator) in which the power sources are prevented from being electrically paralleled or interconnected with each other. Also referred to as a "break-before-make" transfer switch or scheme. An Open Transition transfer results in a momentary loss of power to the load from the two sources during the transfer (an Uninterruptible Power Source is sometimes used to prevent loss of power to the load or part of the load).

OSHA: Occupational Safety and Health Administration. See <http://www.osha.gov>.

Parallel System: A generating facility that can be electrically interconnected to a bus common with the Utility's electric power system and can operate in electrical parallel either on a momentary or continuous basis.

Potential Open Point: For the purpose of this document, a Potential Open Point constitutes any circuit breaker, contactor, switch or similar device that can be opened and/or closed, and which is not equipped with either a sync check or synchronizing function.

Production Meter: An LG&E and KU-owned electric meter installed at a Generating Facility and configured so as to record or allow calculated energy output of the generating facility. The Production Meter will be an AMI type, unless otherwise specified by LG&E and KU.

Point of Interconnection (POI): The physical location where LG&E and KU service conductors are connected to a Customer's conductors, bus, and/or service equipment to allow parallel operation of Customer's generating facility with the LG&E and KU System. Also referred to as the Point of Common Coupling (POCC, or PCC).

Qualifying Facility (QF): Any Cogeneration or Small Power Production Facility that meets the criteria for size, fuel use, efficiency, and ownership as promulgated in 18 CFR, Chapter I, Part 292, and Subpart B of the Federal Energy Regulatory Commission's Regulations.

Radial Line: A distribution line that originates from a substation and is normally not connected to another substation or another circuit sharing the common supply of electric power.

Readily Accessible: Capable of being reached quickly and conveniently on a 24-hour basis without requiring climbing over or removing obstacles, obtaining special permission, keys or security clearances.

Reclosing: The act of automatically re-energizing a utility power line in an attempt to restore power following a fault on the line.

Relay: An electric device that is designed to interpret input conditions in a prescribed manner and after specified conditions are met to respond to cause contact operation or similar abrupt change in associated electric control circuits.

Rotating Machine (also referred to as a "Rotating Generator"): An induction or synchronous machine (or machines) used to generate alternating current (AC) electric power.

Separate System: The operation of a generating facility that has no possibility of operating in parallel with, or potentially back-feeding onto, the LG&E and KU System.

Service Entrance Section (SES): The Customer-owned main electrical panel or equipment located at its premises to which the Utility delivers electric energy via the Utility service drop or service lateral.

Site Inspection (or LG&E and KU Site Inspection): Verification performed by an LG&E and KU qualified representative (inspector) prior to granting permission to parallel/operate a Generating Facility (generating facility). The inspection may include, but not limited to, verification that the generating facility is in compliance with the NEC as adopted by the local AHJ, meets all LG&E and KU and Interconnection requirements, and other applicable local and/or national safety codes.

Small Power Production Facility: A facility that uses primarily biomass, waste or renewable resources, including wind, solar, and water to produce electric power.

Smooth Parallel Transition: A form of Closed Transition Transfer in which the transfer of electrical load between two power sources occurs by electrically synchronizing and paralleling the power sources for a period of time in order to affect a smooth loading (sometimes referred to as “soft loading”) or unloading of the respective power source. A Smooth Parallel Transition is normally accomplished by paralleling the power sources for a period of 5 to 10 seconds.

Source Device: An electrical device (e.g. switching cabinet, primary transition, or primary metering device) which is directly powered by an LG&E and KU Distribution System circuit or feeder at distribution level voltage (34.5 kV or less).

Source Transfer Equipment: Equipment specifically designed and installed to transfer electrical load between two separate power sources. Such equipment may consist of either a Transfer Switch which must be tested and certified to UL 1008/UL 1008A, or a custom engineered Transfer Scheme which is not listed to UL 1008/UL 1008A. The load transfer may be accomplished via either an Open Transition Transfer or via a Closed Transition Transfer.

Static Inverter: An electronic device (or devices) used to convert direct current (DC) power into alternating current (AC) power.

Tap: The beginning connection point of Tap Conductors as defined by NEC Article 240.2.

Tap Conductors: Conductors that, other than service conductors, have overcurrent protection ahead of its point of supply that exceeds the value permitted for similar conductors that are protected as described elsewhere in NEC Article 240.4.

Totalized Metering: The measurement for billing purposes on the appropriate rate, through one meter, of the simultaneous demands and energy consumption of a Customer who receives electric service at more than one SES at a single site.

Transfer Scheme: Source Transfer Equipment which is specifically engineered, and custom designed for the purpose of transferring electrical load from one power source to another. Transfer Schemes are generally not tested to UL 1008/UL 1008A.

Transfer Switch: Source Transfer Equipment which may be designed to be automatically or manually operated for the purpose of transferring electrical load from one power source to another. Transfer Switches must be certified and tested to UL 1008/UL 1008A.

Transfer Trip Scheme: A form of remote trip in which a communication channel is used to transmit a trip signal from the relay location (e.g. utility substation) to a remote location (e.g. generating facility).

Transmission System: Utility-owned high-voltage lines (69 kV or higher) and associated equipment for the movement or transfer of electric energy between power plants and the Distribution System.

UL: Underwriters Laboratories Inc. See <http://www.ul.com>.

UL Listed: Equipment identified herein that is required to be tested and certified to an applicable UL Standard and which shall also be listed and labeled according to Section 110.3 of the NEC.

Utility: The electric power company (in this case LG&E and KU) that constructs, operates, and maintains its electrical power system for the receipt and/or delivery of electric power.

Utility System: See “LG&E and KU System”.

Utility-grade Relays: Relays specifically designed to protect and control electric power apparatus, tested in accordance with the following ANSI/IEEE standards:

- (1) ANSI/IEEE C37.90-1989 (R1994), IEEE Standard for Relays and Relay Systems Associated with Electric Power Apparatus.
- (2) ANSI/IEEE C37.9.01-1989 (R1994), IEEE Standard Surge Withstand (SWC) Tests for Protective Relays and Relay Systems.
- (3) ANSI/IEEE C37.90.2-1995, IEEE Standard Withstand Capability of Relay Systems to Radiated Electromagnetic Interference from Transceivers.

Wholesale Generation: A generating facility connected directly to the LG&E and KU System that sells energy and capacity directly to a utility under a power purchase contract.

SECTION 3 – APPLICABLE STANDARDS

This document is intended to serve as a reference for LG&E and KU engineers and Customers when planning for the parallel operation of a generating facility on the LG&E and KU distribution system. Minimum requirements for generation intertie are identified in the list of standards that follows to provide for safe and effective operation of the LG&E and KU system. Some installations may be required to install additional protection, after a review of the proposed generation installation. No specific protection is provided for the generator by the Intertie Protective Relays (IPR). The IPR and all other protection required for the generator are the responsibility of the interconnecting party.

Where feasible, generation equipment built and certified to applicable IEEE and UL standards will be permitted to be installed with little or no additional protection requirements, at the site of the generation installation. However, multiple installations on a single line or substation, or the installation of a large unit, may have sufficient impact that additional protection will be required.

All inverters to be used for connecting generation to the LG&E and KU system are required to be certified (listed) to applicable UL and IEEE standards. The term certified is understood to indicate a Nationally Recognized Testing Laboratory (NRTL) has tested the device to the appropriate standards. Any inverter not meeting the NRTL certification will either not be allowed to connect to the LG&E and KU system or will be required to install suitable external protection equipment to provide the same level of protection. Further, the inverter vendor must provide upon request copies of the certification of the inverter equipment from the NRTL. Self-certification or certification by a third party that is not listed on the OSHA web site will not be accepted.

For all generation installations, but especially the small residential and commercial installations, it is the responsibility of the generator owner and their engineer/electrician to determine if the operational voltage limits of the inverter will be exceeded at the maximum operational output of the generation during normal operation of the LG&E and KU system. It should be recognized that at certain times of the year, the LG&E and KU system voltage will approach the maximum limit as measured at the meter base of 126 volts on 120 volt nominal base, 252 volts on 240 volt nominal base. The addition of generation can cause this voltage to increase. The voltage at the inverters may become high enough for the inverters to trip off on over voltage. It is the generator owner's responsibility to take the possible voltage rise into consideration in the design of their facility.

Note: Generation will not be permitted to connect to a LG&E downtown network system. Installation of generation equipment on a distribution network can have a negative impact on the operation of the network. The LG&E network protectors cannot be used to isolate the generation from the LG&E system.

The following standards, where applicable, shall be adhered to when installing and operating a customer-sited generating facility or distributed generation.

- **IEEE 929:** Photovoltaic (PV) Systems Interface – small (10kW or less), intermediate (10kW to 500kW) and large (greater than 500kW)
- **IEEE 1547:** Standard for Interconnecting Distributed Resources with Electric Power Systems
- **IEEE 1547.1:** Standard Conformance Test Procedures for Equipment Interconnecting Distributed Resources with Electric Power Systems
- **NFPA 70:** National Electric Code (NEC).
- **NFPA 855:** National Fire Protection Agency Standard for the Installation of Stationary Energy Storage Systems.
- **UL 98:** UL Standard for Enclosed and Dead-Front Switches.
- **UL 1008:** UL Standard for Transfer Switch Equipment.
- **UL 1008A:** UL Standard for Medium Voltage Transfer Switches.
- **UL 1642:** UL Standard for Lithium Batteries.
- **UL 1703:** UL Standard for Flat-Plate Photovoltaic Modules and Panels.

- **UL 1741:** UL Standard for Inverters, Converters, Controllers and Interconnection System Equipment for Use with Distributed Energy Resources.
- **UL 1741 SA:** UL Standard Supplement A for Advanced Inverters, Converters, Controllers and Interconnection System Equipment for Use with Distributed Energy Resources.
- **UL 1973:** UL Standard for Batteries for Use in Light Electric Rail (LER) Applications and Stationary Applications.
- **UL 9540:** UL Standard for Energy Storage Systems and Equipment.

SECTION 4 – LG&E AND KU POLICY ON CUSTOMER-OWNED GENERATION

At LG&E and KU, we know that renewable energy sources such as wind and solar power play a role in supplying the energy needs of our communities. Additionally, the need for customer-sited generation, utilizing traditional spinning generators, may also exist. We want to make it easy for customers to understand safety regulations and to apply to connect renewable energy projects to the electricity grid.

As always, safety is our top priority. The rules and regulations governing the connection of distributed generation equipment are meant to ensure your safety and the safety and protection of LG&E and KU infrastructure.

All customer-sited generating facility installations must follow the interconnection process outlined by the Kentucky Public Service Commission (KY PSC). This process applies to all new installations, and any modifications to existing distributed generation installations. A link to the current KY PSC guidelines and interconnection request can be found here: <https://lge-ku.com/residential/billing/net-metering>

SECTION 5 – DISTRIBUTED GENERATION TYPES

Distributed generators include induction and synchronous electrical generators as well as any type of Static Inverter capable of producing AC power (e.g. Solar PV and Energy Storage). A Separate System is one so designed that the generation never interconnects (operates in electrical parallel) with, or is capable of ever backfeeding, the LG&E and KU System. A Parallel System is one where a Generator can electrically parallel or has the potential to be paralleled with the LG&E and KU System. Such parallel operation may be performed on either a momentary or on a continuous basis.

Customer may elect to configure its Generator as a Separate System with open transition transfer of load between two independent power systems, or Customer may configure its Generator to run in parallel with the LG&E and KU System.

Separate System

A Separate System is one in which there is no possibility of electrically connecting or paralleling a Backup Generator with the Utility System, or of a Backup Generator otherwise posing a potential risk of back-feeding the Utility System. Load must be transferred between the two power systems by utilizing a Transfer Switch specifically designed to operate in an Open Transition Transfer mode. The Transfer Switch must always disconnect the load from the LG&E and KU System prior to connecting it to the Generator. Conversely, the Transfer Switch must also disconnect the load from the Generator prior to re-connecting it with the LG&E and KU System. These requirements apply to both actual emergency operations as well as to testing the Generator.

The Transfer Switch shall satisfy either one of the following design conditions:

- (1) It must be tested and certified to UL 1008 (or UL 1008A), and/or
- (2) It must be a true double-throw, fail-safe mechanical throw-over design which inherently precludes any possibility of the Utility and Generator sources from ever being connected together, even in the event of a switch failure such as welded contacts at one of the power source switch contacts. Note that a Transfer Switch or Transfer Scheme comprised of two interlocked electrical breakers or contactors will not meet this requirement, irrespective of how they may be interlocked. The Transfer Switch for the purpose of qualifying as a Separate System as outlined in this Section shall be of the manually operated type and shall be tested and certified to UL 98.

In addition to meeting either of the design conditions specified above, the Transfer Switch installation shall also meet the following requirements in order to qualify as a Separate System:

- (1) The Transfer Switch must be a permanent installation in the facility and must be inspected by the AHJ.
- (2) The normal source (utility) electrical conductors and the emergency (generator) electrical conductors feeding the Transfer Switch shall not be routed in the same conduit or raceway or in any way share a common enclosure except inside the approved Transfer Switch.

An Open Transition Transfer Switch or Scheme that does not satisfy the requirements for a Separate System as outlined above constitutes a potential back-feed source to the LG&E and KU System. As such, LG&E and KU has certain requirements that must be adhered to.

In addition to submitting an application, if a customer is planning a separate system, the Company requires verification that the transfer scheme meets the non-parallel requirements. This is accomplished by submitting drawings to the Company for approval and, if the Company so elects, by field inspection of the transfer scheme. The Company cannot be responsible for approving the customer's generation equipment and assumes no responsibility for its design or operation. The only reason the Company reserves the right to approve the drawings and/or inspect the transfer

scheme is to ensure that its personnel can safely work on Company equipment, and to ensure that other customers served by the same system will not be adversely affected by the separate system.

Any closed transition switching (“make before break”), even momentary if greater than 100 ms (0 ms for a secondary grid or spot network) per IEEE 1547 and LG&E requirements, is considered parallel operation. Any generator system utilizing a closed transition scheme must be designed and constructed in accordance with the design requirements for parallel operation as further defined in this document.

Portable generators are normally not designed to be connected to a building’s permanent wiring system and are not to be connected to any such wiring unless approved Source Transfer Equipment is used, and the installation is inspected by the AHJ. Opening a source circuit breaker or disconnect switch (such as the main breaker in an SES) in order to connect a portable generator is prohibited. Failure to use approved Source Transfer Equipment can result in back-feed into the LG&E and KU System – the generator voltage can be stepped up to a very high voltage through the LG&E and KU transformer. This can pose a potentially fatal shock hazard to anyone working on the Utility power lines or equipment.

Most Uninterruptible Power Supply (UPS) systems do not specifically meet the separate system criteria, however if they are not capable of back feed (transfer of power to the utility), they will be classified as a separate system. If they can back feed, they must meet the requirements of the IEEE-1547 as well as the technical requirements for parallel operation.

Parallel System

In a Parallel System, a Generator is connected to a bus common with the LG&E and KU System, and a transfer of power between the two systems is a direct result. A consequence of such interconnected operation is that Customer’s Generator must be considered in the electrical protection and operation of the LG&E and KU System.

A Parallel System encompasses any type of generation source capable of sourcing energy (including rotating generators, Solar PV and Energy Storage systems) that can electrically parallel with, or potentially back-feed the LG&E and KU System. This includes any generating facility using a Closed Transition Transfer Switch or Transfer Scheme as well as any Static Inverter that can be configured or programmed to operate in a “utility interactive” mode.

LG&E and KU has specific interconnection, inspection and contractual requirements, as outlined in this document that must be complied with and information that needs to be submitted for all interconnected generators. These requirements include protective relaying, metering, special rate schedules, and other safety and information requirements. In some installations, a “visible open” Disconnect Switch meeting certain requirements, as outlined in Attachment A, may be required to isolate Customer’s System from the LG&E and KU System. The Customer may be responsible for having the generating facility protective schemes tested by a qualified testing/calibration company. LG&E and KU reserves the right to inspect the system and Customer will be required to sign an Interconnect Agreement and, if applicable, an Electric Supply/Purchase Agreement with LG&E and KU.

In certain instances, LG&E and KU and Customer will need to sign a “Non-Parallel Connection Agreement” and/or an “Operating Agreement”. LG&E and KU will advise Customer of requirements after reviewing the proposed design. LG&E and KU does not extend “blanket approval” to any specific type of Generator or generation scheme since each project is site specific and needs to be reviewed on a case-by-case basis.

In addition to the various other requirements specified in this document, Parallel Systems shall specifically comply with the technical requirements outlined in the Interconnection Technical Requirements section of this document.

Types of Generators

There are three general classifications of power producing equipment: synchronous generators, induction generators, and static inverters. Any of these may be used but there are different technical areas to address for each to ensure safe and reliable interconnected operation.

- (1) **Synchronous Generators:** This is the type of generator that most utilities, including the Company, use to produce power. A synchronous generator does not have to rely on the utility system for its excitation. Therefore, a synchronous generator is capable of keeping a utility line energized even after the line has been isolated from other generating sources. Under/over voltage and under/over frequency relays must be installed to prevent this from occurring. The Company reserves the right to inspect the generator's facility.
- (2) **Induction Generators:** An induction generator must inherently have the utility source to establish a magnetic field for generation. Depending on the generator size, this can create a voltage problem. The Company may require the generator owner to install capacitors (and capacitor switching equipment) to limit the adverse effects of reactive power flow on the Company's primary distribution system capacity and voltage regulation. It should be noted, however, that the installation of capacitors for reactive power supply at, or near, an induction generator greatly increases the risk that the induction generator may become self-excited if accidentally isolated from the Company's electrical system. The self-excited induction generator can produce abnormally high voltages which can cause damage to the equipment of Company customers. Over voltage relays can limit the duration of such over voltages but cannot control their magnitude because of the rapid voltage rise which occurs with self-excitation. Because of this, reactive power supply for large induction generators must be studied on an individual basis. In general, self-excitation problems are most likely in areas of low load density. As with large induction machines used as motors, the inrush current resulting from the starting (or synchronizing) of an induction machine used as a generator may cause an instantaneous voltage drop that can create problems for customers of the Company. For this reason, the Company must also study, on an individual basis, the effect the starting (or synchronizing) the induction generator will have on system voltage.
- (3) **Inverter-Based Systems:** Inverter-based systems convert DC power to AC by means of electronic switching. Switching can be controlled by the AC voltage supplied by the utility (line commutated) or by internal electronic circuitry (forced commutated). Line commutated inverters are generally not capable of operating without the utility's AC supply and cannot supply any appreciable fault current or continue to energize loads provided proper protective functions are in place. To accommodate such protective functions, any line-commutated inverter that is electrically paralleled with the LG&E and KU system shall be tested and certified to UL 1741/UL 1741 SA by a NRTL certified by OSHA to perform the UL 1741/UL 1741 SA test standard. Forced-commutated, or self-commutated inverters are capable of energizing load independently of the utility system. Any forced-commutated connected in parallel with the utility would need to be designed for that purpose. LG&E and KU would need to evaluate any connection request on a case by case basis. Under no circumstance shall a self-commutated inverter, which is normally designed to energize a subpanel independently of the utility, be directly connected the utility system unless a full interconnection request has been filed and approved.

SECTION 6 – DESIGN LEVELS

The KY PSC's interconnection guidelines set forth a two-tiered approach to simplify the interconnection process:

Level 1: applies to inverter-based systems up to 45 kilowatts (kW) in capacity, certified to the UL 1741 and complying with IEEE 1547. Systems cannot require the utility to make modifications to its system in order to be interconnected (the KY PSC guidelines provide additional technical requirements that must be met for Level 1 applications; see the order for details). LG&E and KU must notify the customer within 20 business days whether the interconnection application has been approved or denied. There are no application fees or related fees for Level 1 interconnection.

A level 1 generating facility meeting all of the following conditions will be approved:

- (1) For interconnection to a radial distribution circuit, the aggregated generation on the circuit, including the proposed generating facility, will not exceed 15% of the Line Section's most recent annual one-hour peak load. A line section is the smallest part of the primary distribution system the generating facility could remain connected to after operation of any sectionalizing devices.
- (2) If the proposed generating facility is to be interconnected on a single-phase shared secondary, the aggregate generation capacity on the shared secondary, including the proposed generating facility, will not exceed the smaller of 20 kVA or the nameplate rating of the transformer.
- (3) If the proposed generating facility is single-phase and is to be interconnected on a center tap neutral of a 240 volt service, its addition shall not create an imbalance between the two sides of the 240 volt service of more than 20% of the nameplate rating of the service transformer.
- (4) If the generating facility is to be connected to three-phase, three wire primary utility distribution lines, the generator shall appear as a phase-to-phase connection at the primary utility distribution line.
- (5) If the generating facility is to be connected to three-phase, four wire primary utility distribution lines, the generator shall appear to the primary utility distribution line as an effectively grounded source.
- (6) The interconnection will not be on an area or spot network.
- (7) LG&E and KU does not identify any violations of any applicable provisions of IEEE 1547, "Standard for Interconnecting Distributed Resources with Electric Power Systems."
- (8) No construction of facilities by LG&E and KU on its own system will be required to accommodate the generating facility.

If the above requirements are not met, LG&E and KU at its sole discretion, can approve or deny the application based on whether the generating facility can be safely and reliably connected to the distribution system.

Level 2: applies to systems that are not inverter-based or that use equipment not certified as meeting UL 1741 or for systems that fail to meet the other technical requirements outlined for Level 1 Applications. LG&E and KU has 30 business days to process a Level 2 application. LG&E and KU may require customers to submit an application fee of up to \$100 for processing and inspection purposes. If the utility determines that an impact study is needed, the customer is responsible for costs up to \$1,000 for the initial impact study.

The Customer may not operate the generating facility until an Interconnection Agreement is signed by the Customer and LG&E and KU and all necessary conditions stipulated in the agreement are met. If the application lacks complete information, LG&E and KU will notify the customer and processing times may be extended.

SECTION 7 – VOLTAGE LEVELS

There are three types of circuits which connect the Company's generating stations with its substations and customers: Transmission, Primary Distribution, and Secondary Distribution. Generation can be connected, depending on its output voltage, size, and other characteristics, to any one of these systems. This document only addresses primary and secondary distribution voltage interconnections.

- (1) PRIMARY DISTRIBUTION SYSTEM. Some large commercial and small industrial customers are provided service at the available voltages in this system, which is shown below. To which system a customer is provided service depends on the load and proximity of the system to the customer. The Primary Distribution System is used, primarily, to transmit power to the Secondary Distribution System.
 - a. 4,160 V / 2,400 V, three phase, 4-wire
 - b. 12,470 V / 7,200V, three phase, 4-wire
 - c. 13,800 V, three phase, 3-wire
 - d. 34,500 V / 19,920 V, three phase, 4-wire

- (2) SECONDARY DISTRIBUTION SYSTEM. This is the system to which the majority of the Company customers are connected, including those served under the Company's residential rate. The following voltages are available for secondary interconnection:
 - a. 120 / 240 V, single phase, 3-wire
 - b. 208 V / 120 V, three phase, 4-wire
 - c. 240 V, three phase, 3-wire
 - d. 480 V / 277 V, three phase, 4-wire
 - e. 480 V, three phase, 3-wire

Other primary and secondary voltages are rare but may be available in certain areas. System voltages listed above are not available in all locations. To prevent damage to the generation facility or to the utility infrastructure, ensure that the proper application process is followed as defined by the KY PSC.

The size of the generator, the proximity of the various systems with respect to the generator, in addition to other technical considerations will be used to determine which system a generator should (or can) connect to. The customer should consult with the Company, prior to purchasing its equipment, to determine which system is appropriate for interconnection.

This document only provides technical assistance to generators planning to interconnect with the primary or secondary distribution system. Generators connecting at transmission voltage levels (69 kV and above) or for wholesale business at any voltage level are under FERC jurisdiction and must submit an Interconnection Request to the Independent Transmission Operator (ITO) under the Small Generator Interconnection Procedures (SGIP) or Standard Large Generator Interconnection Procedures (LGIP).

SECTION 8 – INTERCONNECTION TECHNICAL REQUIREMENTS

GENERAL

The primary function of the Intertie Protective Relaying (IPR) is to isolate the generator from the LGE/KU system for faults on the LGE/KU system or whenever continued operation would be detrimental to LGE/KU or LGE/KU customers.

The secondary function of the IPR is to block closing of all circuit breakers that can be used to parallel the generation whenever the LGE/KU source is unavailable or abnormal.

GENERAL DESIGN CONSIDERATIONS

- (1) The generator installation must meet all applicable IEEE standards (IEEE 929-latest revision and IEEE 1547-latest revision, and IEEE 1547.1 latest revision) and UL 1741/UL 1741 SA latest version. It must also meet all applicable national, state, and local construction and safety codes.
- (2) The generator owner is responsible for providing the necessary protection for its own system, as well as protecting against adverse effects, from its operation, to the Company's system. Where applicable, the generator owner will provide protection for the various electrical problems outlined in the relaying requirements section.
- (3) The Company will install and own required revenue metering equipment. (See the metering requirements section.)
- (4) As detailed in Attachment A, Disconnect Switch Requirements for Distributed Generation Customers, the Customer shall furnish and install a safety disconnect switch on the Customer's side of the point of interconnection for those installations requiring a separate disconnect switch. Exceptions to this requirement as well as technical requirements are provided in Attachment A. The disconnect switch shall be capable of fully disconnecting the Customer's net metering generator from the Company's electric service under the full rated conditions of Customer's net metering generator. Customer shall be responsible for ensuring the location of the disconnect switch is properly and legibly identified for so long as the net metering generator is operational. The disconnect switch shall be accessible to Company personnel at all times.
- (5) If the customer is under the Small Qualifying Facility tariff (SQF) or the Large Qualifying Facility tariff (LQF) a manual load break disconnecting device will be installed by the Company at the point of the interconnection at the customer's expense. This device will be controlled by the Company to ensure Company personnel can service Company lines and equipment safely. It will be of the type allowing Company personnel to visibly see the electrical break.
- (6) The generator owner shall provide adequate facilities for proper synchronization of its generator with the Company such that synchronization can be accomplished without causing undesirable currents, surges, or voltage dips on the Company's primary distribution system. The generator shall parallel with the Utility without causing a voltage flicker at the point of common coupling (PCC) greater than 5%. Either induction starting (if the inrush will not exceed allowable limits), automatic synchronizing, or manual synchronizing supervised by a synchronizing relay must be provided. The generator owner must never attempt to parallel its system with the Company's primary distribution system when the generator's synchronizing facilities are malfunctioning or inoperative. Manual synchronizing without relay supervision is not permitted.
- (7) The generator owner shall provide means for automatically disconnecting its generator from the Company's primary distribution system for those occasions when the Company's primary distribution system becomes isolated from its source of generation, and for the proper resynchronization of its generator after such interruptions or isolations. Three phase automatic reclosing devices are installed on the Company's primary distribution system; thus, the speed of the generator's automatic isolation

- equipment must be such as to disconnect its generation prior to automatic re-energization of the circuit by the Company. (This is discussed further in the RELAYING REQUIREMENTS section below.)
- (8) For those periods of operation during which generating capacity greater than its load demand, the generator connected to the Company's primary distribution system shall maintain a net power factor of between 0.95 lagging (consuming vars) and unity (1.00). This requirement applies to Buy/Sell Options 2, 3, & 4 unless another voltage-var schedule is approved by the Company.
 - (9) Voltage variations due to the generation shall be within the voltage standards prescribed by ANSI C84.1, Range A.
 - (10) The phase voltages produced by the generator must be balanced. The generated waveform must be sinusoidal and free from distortion and excessive harmonics. Waveform distortion, and/or excessive harmonic content, can produce inaccurate revenue metering registration, increased losses in transformers, false relay operations, interference in telephone communications and radio/television reception, and may affect equipment (such as computers) used by customers served by the Company.
 - (11) Under certain conditions, the Company's primary distribution system may cause unbalanced phase currents to flow in the generator. It is the responsibility of the generator owner to protect its equipment from excessive negative sequence currents.
 - (12) The generator owner may be required to limit the phase and ground fault current contribution to the Company's system by transformer impedance, transformer connection, generator connection, neutral grounding, reactors, or other means.

MULTIPLE LG&E AND KU SOURCES

Under no circumstances shall two or more LGE/KU circuits of differing voltages (12.47 kV and 13.2 kV for example) or multiple circuits of the same voltage be paralleled through generation facilities without prior engineering evaluation and written approval from LG&E and KU. Where one or more sources are intended to back-up the primary supply to a generation facility, the electrical circuit to the primary supply must be interrupted before the circuit to the back-up is closed. (Key switch interlocks or break-before-make transfer switches are suitable devices for this type of transfer.)

RELAYING REQUIREMENTS

The Company is responsible for the quality and reliability of its service and must provide this service in a manner which is safe to the public and its personnel. Therefore, the Company reserves the right to determine what protective equipment it must provide, and to refuse to operate parallel with a generating facility that, in the opinion of the Company's engineering staff, is not (or cannot be) operated in a manner that ensures safe and reliable interconnected operation. A full list of relay types and associated requirements are included in Attachment B, Relay and Protective Device Functions and Requirements.

- (1) Generators connected to the Company's distribution system will be required to install "utility grade" protective relays that meet all ANSI/IEEE relay standards.
- (2) The protection package must be designed to separate the generator from the primary distribution system during faults and during abnormal conditions of frequency, voltage, voltage phase sequence, and non-contractual reverse power flow. It should be understood that the Company must reserve the right to add or delete protective equipment, as may be applicable for a particular generator, according to its size, equipment, or potential impact on the interconnected system and/or Company customers. Refer to the table and figures at the back of this document for a typical interface installation and protection device numbers. The specific requirements are:
 - Short circuits including ground faults. (Devices 50, 67, 59N) A circuit breaker and designated relays will be applied as necessary to provide protection for faults on either the Company's or the generator owner's electrical system.

- Overload. (Device 67) AC directional over current relay will be used to provide overload protection and also back up protection for short circuits.
 - Isolation. (Devices 27, 59, 81O, 81U) Should the Company's circuit to the generator become isolated from the Company's source of generation, the generator may cause abnormal voltage and frequency excursions. To prevent damage from these excursions, under/over voltage and under/over frequency relays will be installed.
 - Phase sequence. (Device 47) The designated relay will monitor the proper sequence for the initial connection and also subsequent connections after Company maintenance to the inter tie circuit.
 - Reverse power. (Device 32) The designated relay will protect against reverse power flow on one-way generator systems.
 - Synchronization Check Function. (Device 25) The designated relay blocks out-of-phase closing and also prevents closing and energizing a dead low voltage bus by the generator.
 - For installations interconnected to the utility through a transformer with connections that will not supply current to a ground fault on the utility system, a ground fault detector may be necessary. LGE/KU will advise Customer of any such requirements after a review of the Customer's proposed installation.
- (3) The generator owner has the dual responsibility of protecting its own equipment while connected to the Company's electrical system, as well as preventing its equipment from causing problems to the Company's system. As a result, the generator owner must provide protection for all of the conditions outlined in the above section, as well as unbalanced load and loss of excitation.

OPERATING REQUIREMENTS

- (1) For generator facilities with total installed capacities of 2.5 megawatts or greater, the Company will install the necessary equipment to telemeter continuous capacity (KW) data, KVAR data (if the generator owner uses a synchronous generator), and hourly energy (KWH) data to the Company's Automatic Generation Control (AGC) system.
- (2) For synchronous generators, a voltage-var schedule, in addition to voltage regulator settings, will be jointly determined by the Company and the generator owner to ensure proper coordination of voltages and regulator action.
- (3) The generating facility owner will maintain an operating log for each of its generators. This log will be used to record the on/off status of the generating unit and to serve as a record of alarms and relay targets (or other indications of unusual conditions). This log must also record all maintenance on the unit, and associated equipment (switch gear, protective relays, etc.).
- (4) The generating facility shall discontinue paralleled operation when requested by the Company:
- To facilitate maintenance, test, or repair of Company facilities.
 - During system emergencies (ref 807 KAR 5:054, Section 6).
 - When the generator's operation is interfering with Company customers.
 - When an inspection of the generating equipment reveals a condition hazardous to the Company's primary distribution system or reveals a lack of scheduled maintenance or maintenance records for equipment necessary to protect the Company's system (and its customers).
- (5) When the intertie breaker is out of service for maintenance, and service to the generating facility for load is maintained through a breaker bypass disconnect, the generator owner must provide a method by which the Company can lock the generator breaker open to ensure personnel and equipment safety during the period of maintenance.

OTHER CONSIDERATIONS

(1) Since each generator installation must be reviewed on an individual basis, it is extremely important that the generator owner contact the Company well in advance of the time parallel operation is desired. The generator owner should not order any equipment until the Company has reviewed the generator's plans and has defined what changes and/or additions will be necessary for safe and reliable interconnected operation. The customer is to provide all drawings necessary for the approval of the installation. The following are some of the approval drawings that may be required for approval:

- Control drawings and specifications
- CT/PT/meter locations
- Transformer data sheet and drawings showing kVA, connections, taps, impedance, primary/secondary voltages.
- One line and/or three line relay drawings/diagrams
- As built drawings

The time required to secure this approval depends on the size and location of the generator's equipment, as well as on other technical considerations. Example drawings are included in Attachment C.

(2) The generating facility cannot commence parallel operation until written approval has been given by the Company. The Company reserves the right to inspect the generating facility and to witness testing of any equipment or devices associated with the interconnection.

(3) The generator owner should be aware that some of the Company provided equipment, discussed in the above paragraphs, have somewhat lengthy delivery times. The time from placing an order, to receiving the equipment, can exceed one year. (The same is true for equipment the generating facility may require, such as large transformers, power circuit breakers, etc.) Therefore, the time required to design, order, receive, and install this equipment should be taken into consideration by a generator owner that is making plans to operate parallel with the Company.

(4) It may become necessary, in the future, to add or modify present technical requirements, and this could also affect existing generators. Such changes might include additional equipment for harmonic filtering, more complex utility relaying schemes, etc. The Company will not change its requirements unless such changes are necessary to ensure safe and reliable interconnected operation.

(5) All costs incurred by the Company to accommodate the interconnection of Customer's generation to LG&E/KU's electrical system must be borne by the customer. These costs include, but are not limited to, the following items:

- Engineering studies and design work necessary to permit the interconnection of the customer's generation to the LG&E/KU electrical system. This includes any preliminary preparation and estimating costs.
- New overhead and/or underground line extensions to interconnect the customer's generation to LG&E/KU's system.
- Conversion of single-phase lines to three-phase construction to accommodate the generation (if necessary).
- Increasing the capacity of LG&E/KU's distribution system to accommodate the customer's generation.
- Alterations, modifications, or additions to LG&E/KU's distribution system protection schemes necessitated by the interconnection of the customer's generation.
- Telemetry facilities, including the cost of equipment and communication facilities as well as maintenance costs associated with these facilities.
- Alterations, modifications, or additions to LG&E/KU's distribution system to maintain the quality of electrical service to LG&E/KU's customers.

PSC regulation for small power production and cogeneration (807 KAR 5:054) requires owners of qualifying facilities “to pay for any additional interconnection costs to the extent that such costs are in excess of those that the electric utility would have incurred if the qualifying facility’s output had not been purchased.” This also applies to any subsequent changes, either to equipment owned by the Company or the generator owner.

GENERAL REQUIREMENTS FOR INVERTER-BASED GENERATION SOURCES

- (1) Any generating facility comprising static inverters with an aggregate generator nominal nameplate rating of 10 MW or less and interconnecting with a Non-Dedicated Utility Feeder, shall utilize inverters that have been tested and certified to UL 1741 with Advanced Inverter functionality (UL 1741 SA or subsequent UL equivalent supporting the latest IEEE 1547 standard), by a NRTL certified by OSHA to perform the UL 1741 SA test standard.
- (2) LG&E and KU reserve the right to require any inverter-based installations with a total peak generating capacity greater than or equal to 1 MW to have an electronic recloser installed at the point of connection. Installations less than 1 MW may also require a recloser with remote controlling and monitoring upon evaluation by LG&E and KU. All costs of the recloser and associated installation will be at the customer’s expense.
- (3) Inverter-based installations with peak generating capacities greater than 500 kW may require supervisory control, alarms, metering, and associated communications as necessary. LG&E and KU will determine this requirement based on a combination of the peak generating capacity, minimum load on the circuit, and the geographical location of the installation.

ADVANCED GRID SUPPORT FUNCTIONALITIES (SMART CAPABILITIES) <10 MW

The requirements outlined in this section apply to generating facilities or net metered installations with an AC output rating of less than 10 MW.

The programming/set points shall be determined per LG&E and KU and proof of such shall be provided by Customer (i.e. certified test report, inverter settings print out, and/or LG&E and KU inspection/validation). Default mode shall be set to unity power factor unless otherwise determined by LG&E and KU. Measurement accuracy shall be in accordance with the latest IEEE 1547 standard.

At a minimum, the following grid support features are required unless otherwise specified:

- (1) Volt/var Mode – Voltage/VAR control through dynamic reactive power injection through autonomous responses to local voltage measurement
- (2) Volt/Watt Mode – Voltage/Watt control through dynamic active power injection through autonomous responses to local voltage measurement
- (3) Fixed Power Factor – Reactive power by a fixed power factor
- (4) Constant Reactive Power – Reactive power by a fixed percentage of kVA rating of the inverter nameplate (limited to 44%).
- (5) Anti-Islanding – Support anti-Islanding to trip off under extended anomalous conditions
- (6) Low/High Voltage Ride-Through (LHVRT) – Ride-through of low/high voltage excursions beyond normal limits
- (7) Low/High Frequency Ride-Through (LHFRT) – Ride-through of low/high frequency excursions beyond normal limits
- (8) Ramping – Capability to define active and reactive power ramp rates (typically managed by a DER plant control system)
 - a. Settings shall not cause voltage excursions outside of the limits specified in Section 8.4(F).
 - b. DER steps shall not exceed limits specified within Section 4.10 of IEEE 1547-2018.
- (9) Soft-Start Reconnection – Reconnect after grid power is restored

- (10) Cease to Energize – Capability to remotely turn off active power delivery
- (11) Power Curtailment – Capability to remotely curtail the active power production within the range of 0% to 100%
- (12) Frequency/Watt Mode – Frequency/Watt control to counteract frequency excursions beyond normal limits by decreasing or increasing real power

LG&E and KU reserves the right to specify the operating mode in which the Customer will operate the generating facility. If such a case arises, LG&E and KU will specify the associated set point(s). Such specification may be based upon the results of the Interconnection Study and/or changes to, or conditions arising on, the LG&E and KU System.

ADVANCED GRID SUPPORT FUNCTIONALITIES (SMART CAPABILITIES) >10 MW

Any generating facility, with an aggregate generator nominal AC nameplate rating of 10 MW and greater, shall be capable of meeting all of the operational/control modes specified below. As part of the Interconnection Study, LG&E and KU will specify whether these operational/control modes shall be measured at the inverters, service entrance or Point of Interconnection (POI).

- (1) Capability to operate in Power Factor Control (“PFC”) mode at a fixed power factor within the range of at least plus or minus 0.95 pf at any power output level up to the maximum rated MW output of the generating facility. If the point of measurement is different from the POI, it may be necessary to have a wider range of PF setpoints in order to deliver enough reactive power to the POI. Power Factor Control mode is defined as a site varying its reactive power output to achieve a constant power factor output. PFC may be unstable at very low loads. Generating facilities may revert back to unity power factor operation when operating below 10% of nameplate MW capacity. Battery Storage based generating facilities should be able to operate in Power Factor Control mode whenever importing or exporting more than 10% of nameplate MW capacity.
 - Customer shall set the generating facility to operate at 0.98 leading unless a different set point or operating mode is specified by LG&E and KU.
 - The reactive power level calculated at 0.95 power factor (either lagging or leading) with the generating facility producing full rated real power output represents the required reactive power capability of the generating facility. The generating facility must be capable of delivering or absorbing this amount of reactive power at the POI in any of the active control modes specified in this Section.
- (2) Capability to operate at any fixed reactive power (“Mvar”) output at any power level within the full reactive power range while the generating facility is producing power. Battery Storage generating facilities should be able to operate at any fixed reactive power output level while the inverters are connected to the grid.
- (3) Capability to operate in Automatic Voltage Regulating (“AVR”) mode to regulate the voltage to a selected voltage set point within a voltage range of 0.95 pu to 1.05 pu at the point of measure, to the extent that such voltage regulation can be achieved with the available reactive power capability. Voltage regulation shall be within 0.50% of the voltage set point.

LG&E and KU reserves the right to specify whether Customer will operate the generating facility in PFC, Mvar or AVR mode. If such a case arises, LG&E and KU will specify the associated set point(s). Such specification may be based upon the results of the Interconnection Study and/or changes to, or conditions arising on, the LG&E and KU System.

SOURCE TRANSFER EQUIPMENT

The requirements outlined in this Section apply to a Customer facility utilizing Source Transfer Equipment to transfer all or part of the facility electrical load between two or more power sources – typically one source being the Utility and the other being a Backup Generator.

Typically, Source Transfer Equipment consists of either a transfer switch listed to UL 1008/ UL 1008A, or a true double throw switch listed to UL 98. This equipment meets the LG&E and KU Open Transition requirements; therefore, customer is not required to install a Utility Disconnect Switch.

Other types of Source Transfer Equipment may be comprised of custom-built transfer schemes, such as Kirk-key interlocks, two main transfers, main-tie-mains, etc. These are not listed to UL 1008/UL 1008A and are considered to be a potential back-feed source. Therefore, customer will be required to install a Utility Disconnect Switch and submit drawings showing the interlock logic for LG&E and KU review and approval.

While either a Transfer Switch or Transfer Scheme may be used to transfer Customer load between a Utility source and a Backup Generator, a Transfer Scheme must be used when transferring from one Utility source to another Utility source, for instance when a Customer is fed via two Utility services. While Backup Generators are designed to primarily operate in a stand-alone mode (electrically isolated from the Utility source) in order to power emergency load, they may be designed to electrically parallel with the utility for short periods (< 15 seconds) in order to affect a power transition between power sources.

All Source Transfer Equipment shall have adequate interrupt ratings and fault withstand capabilities in accordance with OSHA Rules and Regulations as well as NEC Articles.

The connection with, and the operating modes of, Source Transfer Equipment connected to the LG&E and KU System is subject to LG&E and KU review and acceptance as is described below. LG&E and KU may request additional details following LG&E and KU receipt of a Customer Application and associated Supplementary Information. An Interconnection Study may be required depending on the size, configuration, location and/or operating mode of the Source Transfer Equipment. LG&E and KU will advise Customer of any such requirement following an initial engineering review of the proposed design.

SECTION 9 – METERING REQUIREMENTS

This Section applies to any Generating Facility that electrically parallels with the LG&E and KU System other than a Backup Generator.

The Customer must provide and install, at Customer's expense, meter sockets and metering cabinets in accordance with LG&E and KU service standards, in Readily Accessible locations acceptable to LG&E and KU, to accommodate any meter(s) that are required by applicable rate schedule(s) or other LG&E and KU agreement or other LG&E and KU requirements. Such standards are specified in the LG&E and KU Electric Service Handbook, available at the following websites: <https://lge-ku.com/residential/guides> or <https://lge-ku.com/business/guides>

LG&E and KU will furnish, own, install and maintain meter(s) as required by LG&E and KU, and any meter(s) that may be required by the applicable electric rate schedule to measure the output of the customer-sited Generator(s). The responsibility for the costs of providing and maintaining any required meters and communication circuitry as required will be specified in the applicable rate schedule or other LG&E and KU agreement. In some installations, multiple meters may be required depending on the applicable rate schedule. Refer to the LG&E and KU Rates and Tariffs, readily accessible on the Company's website, or your agreement with LG&E and KU for specific metering requirements related to your rate schedule.

Any Metering provided by LG&E and KU as described in this Section shall be located at the customer's service entrance in a standalone meter base, or in appropriately sealed compartments of switch gear, and no Customer wiring, connections, or equipment is permitted in any such sealed metering compartment or meter base.

Where an intertie transformer is used, the Company will install metering on the high voltage side (and/or on the low voltage side with loss compensation) to measure KWH (in), KWH (out), KW (in and out), and KVARH (in and out), where applicable. All revenue meters will be provided by the Company. Space for Company metering equipment must be provided by the generator owner and must be accessible to the Company at all times. The Company reserves the right to require additional metering (and associated communications equipment) as may be required. The generator owner must provide space in its switch gear for the Company to install this equipment.

If Customer installs third party metering equipment, Customer shall ensure that no wiring, or other Customer-owned equipment enters into any LG&E and KU sealed compartment or enclosure. CTs and associated circuitry installed shall be in accordance with the NEC and manufacturers' instructions and shall not violate the UL listing of the metering enclosure or switch gear. Proof of such may be required by LG&E and KU. Customer-installed meters and associated equipment installed to measure Generator output shall be located on the Generator side of LG&E and KU Production Meter. Third party metering equipment must be clearly labeled to distinguish it from the LG&E and KU Production Metering equipment.

SECTION 10 – SCADA COMMUNICATIONS REQUIREMENTS

An LG&E and KU SCADA remote terminal unit (RTU) will be required for rotating generator installations equal to or above 2.5 MW. All costs incurred must be borne by the customer. The RTU will allow LG&E and KU to remotely determine:

- Status of all circuit breakers and motor-operated switches between the point of common coupling and the generator(s). This would include the high side breaker, low side breaker, and generator breaker.
- Three-phase megawatt and megavar flows at the point of contact.
- Three phase voltage at the point of contact.
- Hourly integrated megawatt hours delivered to the LG&E and KU system.
- Hourly integrated megawatt hours delivered to the generation facility.
- Status of the direct transfer trip and protective relay equipment.
- Alarm condition of various pieces of equipment considered critical.

A SCADA-controlled trip control from LG&E and KU to the generator facility may be required and will be evaluated on a case-by-case basis. At the generator option, any of the following devices may be operated (tripped) by this SCADA trip signal:

- (1) The high side breaker
- (2) The low side breaker
- (3) The generator synchronizing breaker (if different from 1 or 2 above).
- (4) The unit Master Fuel Trip device
- (5) The Turbine Master lockout device UNIT TRIP SIGNAL
- (6) The Turbine Stop valves

The intent of the SCADA UNIT TRIP SIGNAL is to isolate the generation from the LG&E and KU system, in the safest possible manner. At some locations, operation of the high side breakers may cause the generation to over speed. The above optional trips are designed to allow for a more controlled shut down of the generation, by eliminating the fuel flow, or energy source to the turbine BEFORE the breaker between the generator and LG&E and KU system is opened. For these installations, the LG&E and KU SCADA UNIT TRIP SIGNAL will be used to provide the trip signal. The generator will provide a suitable interface from the LG&E and KU SCADA to their equipment.

SECTION 11 – RATE SCHEDULES APPLICABLE TO DISTRIBUTED GENERATION

LG&E and KU has adapted a Net Metering Service (NMS) tariff that complies with all provisions of the Interconnection and Net Metering Guidelines approved by the Public Service Commission of Kentucky (PSC) which can be found at as Appendix A to the January 8, 2009 Order in Administrative Case 2008-00169. This service is available to any customer-generator who owns and operates a generating facility located on Customer’s premises that generates electricity using solar, wind, biomass or biogas, or hydro energy in parallel with the Company’s electric distribution system to provide all or part of the Customer’s electrical requirements and who executes Company’s written Application for Interconnection and Net Metering. The generating facility shall be limited to a maximum rated capacity of 45 kW.

Qualifying generators not on the NMS and less than 100 kW can qualify for the Small Capacity Cogeneration and Small Power Production Qualifying Facilities tariff (SQF). Qualifying generators greater than 100 KW can qualify for the Large Capacity Cogeneration and Small Power Production Qualifying Facilities tariff (LQF). All retail customers with generators connected in parallel with the Company that sell any energy or capacity to the Company will be under the Net Metering (NM), Small Qualifying Facility (SQF), or Large Qualifying Facility (LQF) tariffs.

Attachment A

DISCONNECT SWITCH REQUIREMENTS FOR DISTRIBUTED GENERATION CUSTOMERS

PURPOSE AND SCOPE

This document describes the requirements for low-voltage (0–600 V), isolating, disconnect switches on customer generation systems interconnected to a LG&E and KU overhead or underground service. This document also describes LG&E and KU’s minimum functional and location requirements for switches. A disconnect switch device provides a visible open clearance point when it is necessary to isolate the customer’s generator from the LG&E and KU system.

EXEMPTION TO THE DISCONNECT SWITCH INSTALLATION REQUIREMENT

Applicants with inverter-based generating systems that are supplied by LG&E and KU single phase services up to 240 volts may be exempted from installing a disconnect switch, as determined by LG&E and KU, if interconnection with the generation source(s) meets all of the following conditions:

- (1) The meter base is self-contained (not transformer-rated).
- (2) The meter base accepts form "S" socket-based (e.g., FM2S) meters (not bolt-on meters).
- (3) The meter base is rated for 320 amps (CL 320) or less of "continuous" current.
- (4) Service voltage is single-phase, 120/240 volt or 120/208 volt.
- (5) Generator power output must be less than or equal to 10 kVA.
- (6) Inverter must be UL listed or IEEE 1547 compliant (for inverter-based generation only).
- (7) Generator must not be capable of self-commutation or generating its own voltage in the absence of grid supply voltage.

Any generation system that does not meet all of the conditions listed above for the generator/inverter, service voltage, and meter panel, must install a disconnect switch, as required by LG&E and KU and described in this document.

GENERAL INFORMATION

1. Provide a disconnect device to electrically isolate the customer's generator from the LG&E and KU system in order to establish a clearance point for maintenance and repair work in accordance with LG&E and KU safety rules and practices. The isolating disconnect device does not have to be rated for load break and therefore must not be used to make or break parallels between the LG&E and KU system and the generator(s).
2. Only use alternating current (ac) disconnect switches specifically approved by LG&E and KU for this purpose. LG&E and KU employees shall be allowed to inspect and approve the installation before operation of the customer's generation system will be permitted. This process may be performed through the standard application and drawing submittal process and/or on-site inspection.
3. The disconnect device must be installed between the LG&E and KU meter and all generation sources.
4. The disconnect device must be physically located for ease of access and visible to LG&E and KU employees within 10 feet of the meter. The device must be located in close proximity, or within line of sight, of the meter.
5. General or light duty disconnect switches typically are installed when the voltage is 240 V or less and the ampere rating 600 amps or less. Use heavy-duty disconnect switches for all applications above 240 V and/or 600 amps.
6. The ampacity rating of a disconnect switch must be equal to or greater than the ampere rating of the generator.
7. The neutral conductor shall not be switched and connected per NEC requirements. If a 3-phase switch is used for single/split phase service, the neutral shall not be terminated on any switched terminal and shall either pass through the disconnect switch enclosure or terminate on a dedicated neutral bus bar.
8. Three-pole switches may be used in single-phase applications.
9. Disconnect switches with an interlock are allowed provided they meet all of the functional requirements. An interlock system allows the switch to be opened (off) by the producer but cannot be closed (on) until reset by LG&E and KU.
10. All disconnect devices must have locking provisions that accept a LG&E and KU padlock with a 5/16-inch lock shaft. Keyed locks are not allowed. If the disconnect device is operable without opening the enclosure, the operating handle must be lockable. If the enclosure must be opened to operate the disconnect device, the enclosure must be lockable.
11. Molded case circuit breakers, pull-out type disconnects, or any other similar device are not acceptable as an approved disconnect switch.
12. For applications not described, contact the LG&E and KU Electrical Engineering & Planning department.
13. Interconnections in any LG&E and KU sealable compartment are NOT allowed without written authorization from the Electrical Engineering & Planning department. For any questions, contact LG&E and KU's Electrical Engineering & Planning department.

DISCONNECT SWITCH REQUIREMENTS

Basic

As specified in the LG&E and KU Interconnection Requirements for Customer-Sited or Distributed Generation, the generating facility must have an ac disconnect switch, unless it qualifies for exemption based on the criteria listed in this document under “Exemption to the Disconnect Switch installation Requirement.” When required, the device must meet all of the LG&E and KU requirements, as specified in this document.

All disconnect switches must conform to nationally recognized standards and meet all applicable certification requirements. These include but are not limited to: NFPA 70–National Electrical Code (NEC), Underwriters Laboratories (UL), or other Nationally Recognized Testing Laboratory (NRTL).

Functional

- Manually operated: Operated by a person and not operated electronically.
- Gang-operated: One switch handle opens and closes all phases simultaneously.
- Includes marking or signage on the switch that clearly indicates the open (off) and closed (on) positions.
- Lockable in the open (off) position using a LG&E and KU padlock.
- Allows visible verification that an air-gap of separation has occurred between the blades and contact points.
- A fusible ac disconnect switch is required for generators that do not have over-current protection (i.e., breakers, fuses) at the point of interconnection with the utility.
- Adequately sized to handle fault and overcurrent conditions.

Location

- Easily accessible by LG&E and KU 24/7, when requested.
- Located on the same wall as, and in line of sight of, LG&E and KU’s electric revenue meter.
- Distance between meter base and disconnect switch shall be a minimum of 6 inches and a maximum of 3 feet. If disconnect switch cannot be located next to the meter base, customer shall provide labeling as to the location of the disconnect switch.
- When wall–mounted or floor standing (pad–mounted), installed at a typical vertical height of 5 feet 6 inches (66 inches), as measured from the ground to the center of the disconnect switch enclosure.
- Clearly marked on the submitted single-line diagram indicating the manufacturer, model type, voltage rating, current rating, and location.
- Installed in a safe and acceptable location that meets the same working space requirements as a meter panel.

DEFINITIONS:

Back Feed: The energizing of a utility's distribution system from a non-utility generation source.

Disconnect Switch: A disconnect device that the customer is required to install and maintain in accordance with the requirements described in this document. It will completely isolate the customer's generating facility from the electric utility's distribution grid. The device includes a visible open, as defined below.

Distributed Generation: Any type of customer-owned electric generator, static inverter, or generating facility that has the capability of being operated in parallel with an electric utility's distribution system.

Distribution System: The infrastructure constructed, maintained, and operated by a utility to deliver electric service to retail customers at primary and secondary distribution voltages.

Generating Facility: All or part of the customer's electrical generator(s) or inverter(s) together with all protective, safety, and associated equipment necessary to produce electric power at the customer's facility.

Onsite Generation System: A facility or energy system for generating of electricity that:

- Uses renewable energy to generate electricity.
- Is isolated from the distribution system at the customer's premise when the utility grid is de-energized.
- Operates in parallel with the utility's distribution facilities.
- Is intended primarily to offset part or all of the customer's requirements for electricity.

Open Position: The disconnect blades are separated from the contacts for each phase, preventing the flow of electricity between them.

Visible Open: An air gap must be visible at the trailing edge of the moveable disconnect blades when the switch is in the open position.

RELEVANT DIAGRAMS AND FIGURES

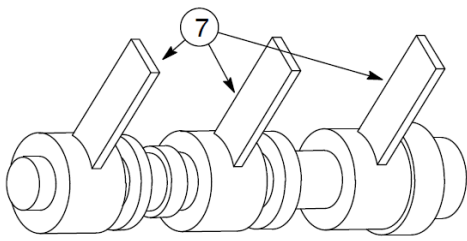

Detail A – Blades

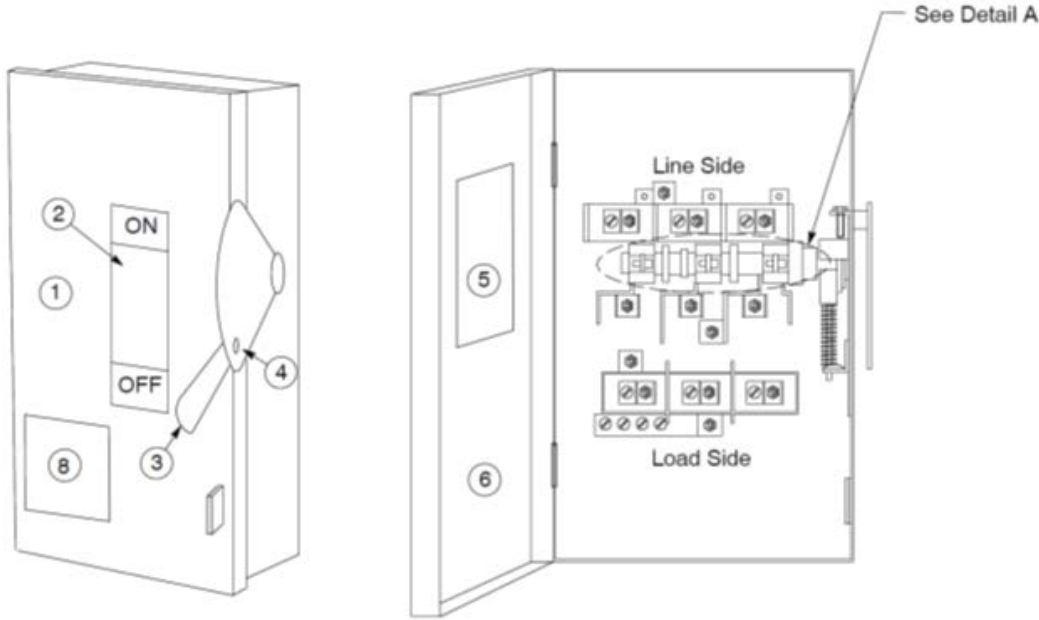

Figure 1 - Typical AC Disconnect Switch

Table 1 - List of Items Required for the AC Disconnect Switch

Item	Description
1	AC Disconnect Switch Enclosure – General or heavy-duty, indoor or outdoor, fused or unfused, UL/NRTL certified. As required.
2	Visible ON/OFF label.
3	Switch Handle – Manual, single pole for gang operation.
4	Provision for Locking in the Off (Open) Position – Accommodates a LG&E and KU padlock with 5/16-inch lock shaft.
5	Device Label – Includes relevant information (device ratings, UL certification, etc.) about the device.
6	Operable Door – Allows visible verification of blade position. Viewing window is optional.
7	Blades – Solid or Fused. Allows visible verification that separation from contacts has occurred.
8	Label stating “Utility Disconnect Switch” – Placed on the outside in the front of the disconnect switch.

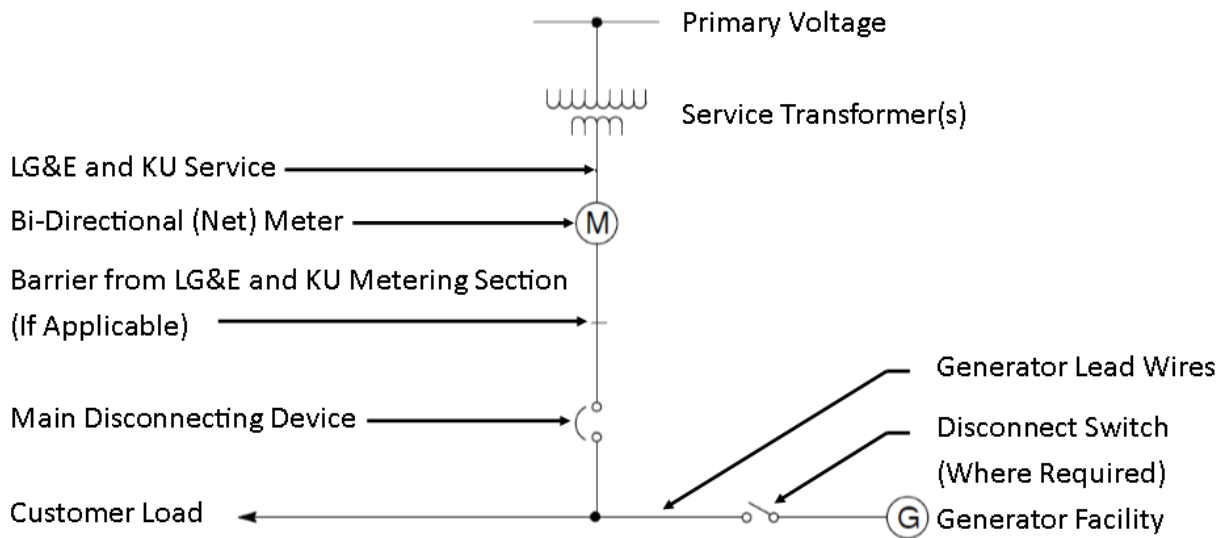

Figure 2 - Typical Disconnect Switch Wiring Diagram

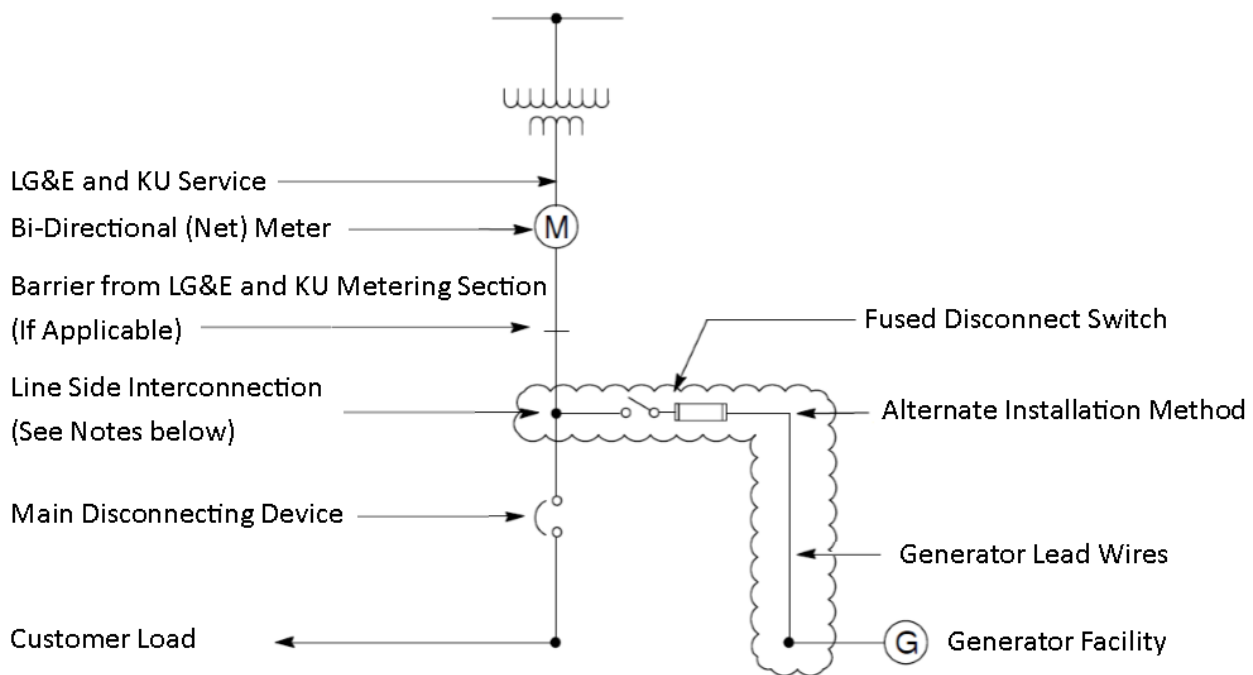

Figure 3 - Alternate Installation Method

NOTES (Figure 3):

- (1) Line side interconnection shall be made outside of the meter base in a junction box separate from the meter.
- (2) Fused disconnect must comply with all applicable NEC requirements for installation and rating.

NOTE:

1. LOAD BREAK DISCONNECT SWITCH IS PROVIDED/INSTALLED BY THE CUSTOMER.
2. DISCONNECT SHOULD BE LOCATED ON SAME WALL AS METER BASE. DISTANCE BETWEEN METER BASE AND DISCONNECT TO BE A MINIMUM OF 6 INCHES AND A MAXIMUM OF 3 FEET.
3. IF DISCONNECT CANNOT BE LOCATED NEXT TO THE METER BASE CUSTOMER SHALL PROVIDE LABELING AS TO THE LOCATION OF THE DISCONNECT SWITCH. LOCATION MUST BE ACCESSIBLE TO THE UTILITY 24/7.
4. METER BASE TO BE INSTALLED AT A TYPICAL HEIGHT OF 5'-6" TO THE CENTER OF BASE ABOVE GRADE.
5. DISCONNECT TO BE INSTALLED ON EITHER SIDE OF METER BASE AT THE SAME LEVEL. DO NOT INSTALL DISCONNECT DIRECTLY ABOVE OR BELOW METER BASE EXCEPT WHERE APPROVED BY LG&EKU.
6. LINE SIDE WIRES TO BE CONNECTED TO TOP LUGS OF METER BASE AND THE DISCONNECT SWITCH.
7. LOAD SIDE WIRES TO BE CONNECTED TO BOTTOM LUGS OF METER BASE AND THE DISCONNECT SWITCH.

8. CUSTOMER IS RESPONSIBLE FOR THE CONNECTION FROM THE DC TO AC INVERTER TO THE DISCONNECT SWITCH AND THE DISCONNECT SWITCH TO THE CUSTOMER PANEL.
9. CUSTOMER IS RESPONSIBLE FOR THE CONNECTION TO THE LOAD SIDE FROM THE METER BASE TO THE CUSTOMER PANEL. NO ADDITIONAL CONNECTIONS MAY BE MADE IN THE METER BASE.
10. SWITCH TO HAVE LABEL "PHOTOVOLTAIC SYSTEM UTILITY DISCONNECT SWITCH."
11. METER BASE AND DISCONNECT SWITCH TO BE INSTALLED TO MEET ALL APPLICABLE REQUIREMENTS OF THE NATIONAL ELECTRIC CODE (NEC).

SWITCH REQUIREMENTS

1. DISCONNECT SWITCH IS TO BE PURCHASED, INSTALLED AND OWNED BY THE CUSTOMER.
2. BREAKERS AND/OR FUSED DISCONNECTS ARE NOT ALLOWED.
3. DISCONNECT MUST PROVIDE A VISIBLE OPENING OF THE PHASES. UTILITY WILL HAVE INTERNAL ACCESS TO DISCONNECT SWITCH 24/7.
4. DISCONNECT MUST INCLUDE A HANDLE FOR OPERATION THAT IS LOCKABLE IN THE OPEN AND CLOSED POSITION. DISCONNECT SWITCH COVER MUST BE SECURABLE BY A PADLOCK.
5. DISCONNECT SWITCH COVER MUST BE SECURABLE BY A PADLOCK.
6. DISCONNECT MUST BE RATED FOR THE AVAILABLE FAULT CURRENT PER THE NATIONAL ELECTRIC CODE.

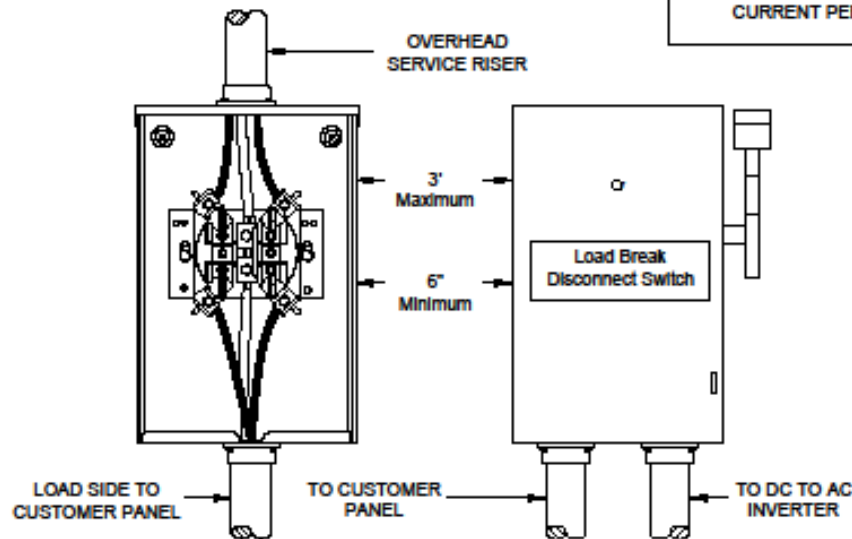

CLEARANCE REQUIREMENTS:

1. DISCONNECT SWITCH TO HAVE SAME CLEARANCE REQUIREMENTS AS THE ELECTRIC METER BASE. SEE STANDARD 812001 AND 812002 FOR MORE DETAILS.
2. METER BASE AND/OR DISCONNECT SWITCH MUST BE A MINIMUM OF 3 FEET AWAY FROM GAS METER (IF PRESENT) MEASURED HORIZONTALLY.
3. METER BASE AND/OR DISCONNECT SWITCH TO BE INSTALLED 5'-6" ABOVE GRADE OR 6'-6" ON DRIVEWAYS OR SIDEWALKS.
4. METER BASE AND/OR DISCONNECT SWITCH TO MAINTAIN 2 FEET OF CLEAR WORKING SPACE TO ANY OBSTRUCTIONS.

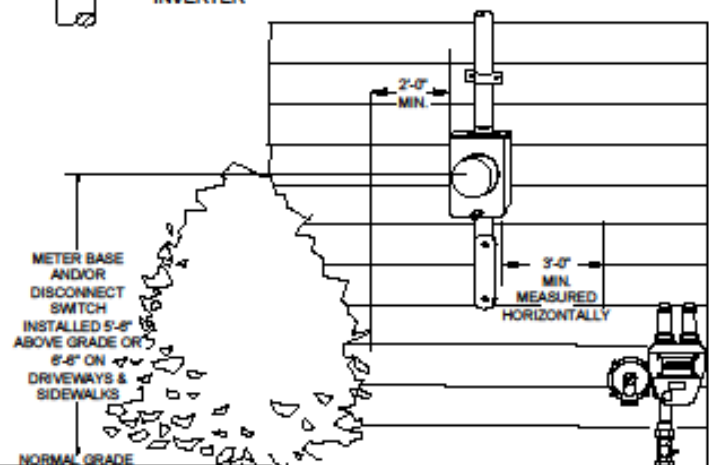

Attachment B

RELAY AND PROTECTIVE DEVICE FUNCTIONS AND REQUIREMENTS

Device	Function	Description	Time Delay Settings
21Z1	Zone 1 Distance	Provides a trip signal for a power system fault of the LG&E and KU supply line.	As per the requirement.
21Z0S	Out-of-step	Provides a trip signal for loss of power system-generator synchronism.	As per the requirement.
25	Synchronism Check	Provides a 'permission to close signal' to the breaker used to parallel the generation to the LG&E and KU system.	As per the requirement.
27GEN	Generator Voltage Check	Used to block closing of generator breaker (or other) if voltage is present on the generator side. Used primarily with induction generators.	As per the requirement.
27T	Time Delay Undervoltage	Set at 88% of nominal voltage with a time delay to override local voltage dips.	0 - 2 Sec.
27I	Instantaneous Undervoltage	Provides a trip signal of an undervoltage condition for less than 50% of nominal voltage; also provides a block closing signal until source is normal.	0 - 0.160 Sec.
27N	Narrow Band High Accuracy Undervoltage	Set above 27I or 27T; provides an alarm to generator operator and a trip after a delay (via 62L) of several minutes. (99% reset)	As per the requirement.
27DC	Battery Monitor	Set to trip the generator breaker when the battery reaches @90% of nominal DC voltage with a time delay sufficient to override momentary voltage transients.	0 - 10 Sec.
32	Power Directional	Monitors power flow into LG&E and KU system.	0 - 5 Min.
51V	Torque-Controlled Time Overcurrent	Set to approximately 25% of the machine full load rating with the torque control being supplied by the 27 relay(s).	As per the requirement.
50/51	Time and Instantaneous Overcurrent	This is the phase overcurrent protection to monitor phase current flow on the high side of the transformer.	As per the requirement.
50/51N	Time and Instantaneous Overcurrent Neutral	This relay is connected to monitor the neutral current flow in the high side of WYE connected transformers. It is usually set to 1 amp secondary current.	As per the requirement.
59T	Time Delay Overvoltage	Set at 110% of nominal voltage.	0 - 1 Sec.
59I	Instantaneous Overvoltage	Set at 120% of nominal voltage.	0 - 0.160 Sec.
59N	Narrow Band High Accuracy Overvoltage	Set below 59I/59T; provides an alarm to generator operator and a trip after a delay (via Overvoltage 62L) of several minutes.	As per the requirement.
62	Auxiliary Timer (Short Time)	Used with 27I and/or 59I to produce 27T and/or 59T function.	As per the requirement.

62L	Auxiliary Timer (Long Time)	Used with 27N and 59N to provide several minute delay to allow plant operator to correct voltage deviation.	As per the requirement.
67	Directional Overcurrent	This is the IPR protection and it connected to monitor directional phase current flow on the high side of the transformer.	As per the requirement.
81O	Over Frequency	Typically set at 60.5 Hz.	0 - 0.160 Sec.
81U	Under Frequency	Typically set at 59.3 Hz for generation less than 45 kW.	0 - 0.160 Sec.
		Typically set at 57.0 Hz for generation greater than 45 kW.	0 - 0.160 Sec.
		May be set between 59.8 to 57.0 Hz for large (greater than 45 kW) units to coordinate with load shedding relays.	0 - 300 Sec.
DTT1	Direct Transfer Trip	Sends a signal from LG&E and KU Terminal A to trip generator.	As per the requirement.
DTT2	Direct Transfer Trip	Same as DTT1 except to Terminal B.	As per the requirement.

Attachment C

EXAMPLE(S) OF ACCEPTABLE SCHEMATIC DIAGRAMS

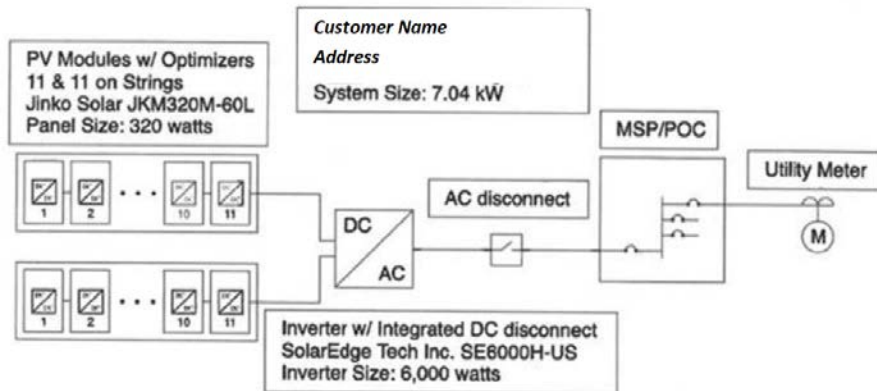

Figure 1 - Example simplified single line electrical diagram for solar PV installation.

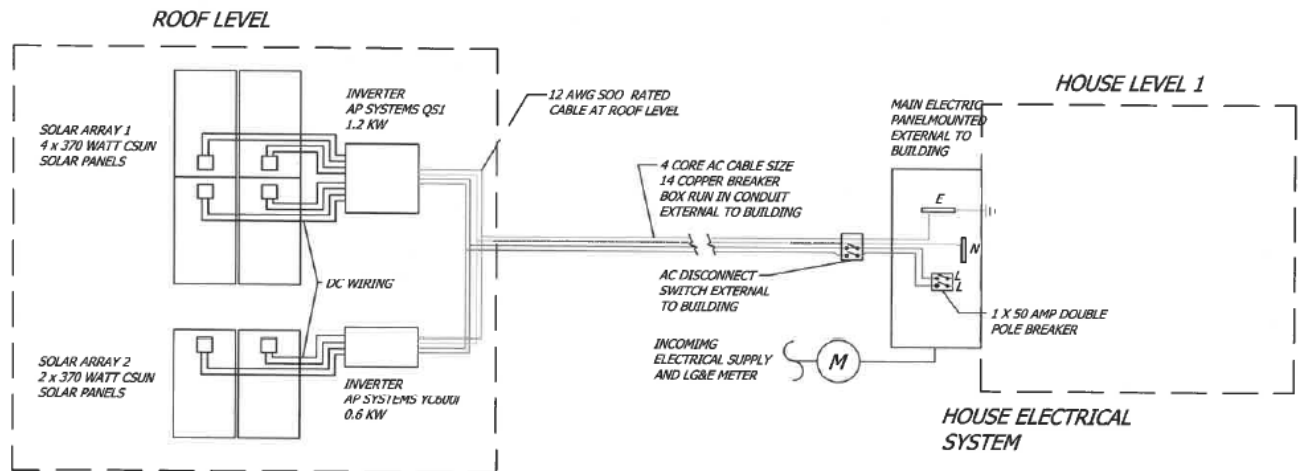

Figure 2 - Example detailed electrical schematic for solar PV installation.

Attachment D

LG&E AND KU PARALLEL STANDBY GENERATION REQUIREMENTS

The following figures are available on the LG&E and KU website [here](#) for residential installations and [here](#) for business installations and are individually hyperlinked below.

SPEC-251 C: [Type 1 – Line Side of Customer Transformer Connected Grounded Wye Only](#)

SPEC-252 C: [Type 2 – Line Side of Customer Transformer Connected Ungrounded Wye or Delta](#)

SPEC-251 D: [Type 3 – Secondary Interconnect to 4.16 kV, 12.47 kV, or 34.5 kV System](#)

SPEC-252 D: [Type 4 – Secondary Interconnection to 13.8 kV System](#)