

Electric Service Customer Guide

Distribution Operations | Asset Management



Revised March 2025

Louisville Gas and Electric Company (LG&E) provides retail gas and electric service in a defined service territory in and around the Louisville, Kentucky area. The contents of this handbook are intended to address utility-provided electric service issues within the prescribed service territory. A separate document, "Customer Gas Piping Handbook", details customer requirements for natural gas service.

This handbook provides LG&E's customers and/or their contractors with important information to help ensure that customer-owned electrical facilities interface safely and reliably with those of the utility. It presents LG&E's approved construction methods for facilities, including metering facilities provided by the customer for the utility's use. It also details certain requirements for the construction of the interface point between customer and utility wiring. Additionally, it addresses some important procedural aspects involved with service modifications, repairs and conversions. Following the instructions in this manual will help LG&E meet your needs in a timely and efficient manner. Although the book covers service requirements for the most common types of installations, it is an abbreviated guide and does not cover service requirements for complex or special installations. LG&E service representatives are available to assist customers in complying with the requirements of this handbook and to provide additional support that may be required to complete complex or non-standard projects.

The intention of this guide is to meet or exceed the requirements of the Kentucky Uniform Building Code, National Electrical Code, Kentucky Public Service Commission Rules and Regulations, National Electrical Safety Code and other relevant publications. However, the information contained herein does not preempt any of the rules, codes or regulations contained in the aforementioned publications. It is the customer's responsibility to notify LG&E of any conflicts between utility standards and the requirements of any of the above publications.

The Kentucky Uniform Building Code requires that all customer-provided electrical facilities meet the requirements of the National Electrical Code and any other state or local ordinances in existence at the time of installation. It also requires that all new electrical facilities and any repairs or modifications made to existing electrical facilities be inspected and approved by a certified electrical inspector of the Inspection Authority having jurisdiction. LG&E is prohibited from extending or reconnecting permanent service before the Authorized Inspection Authority has approved all work.

By publishing this handbook, LG&E is not assuming liability or responsibility for the customer's internal wiring, equipment or equipment operation. Furthermore, LG&E maintains the right to refuse service to installations, which do not comply with LG&E's requirements for service or are found to be either unsafe or unacceptable to the Authorized Inspection Authority. LG&E is not responsible for the continuing inspection or surveillance of the customer's wiring, equipment or equipment operation.

LG&E recognizes that alternate designs may be permissible under governing codes and regulations. However, LG&E must grant approval to any alterations or exceptions to the requirements of this guide prior to construction. **LG&E reserves the right to modify the requirements found in this handbook or any of its service policies, procedures and/or standards at any time. It is the responsibility of the customer or contractor to ensure that any referenced document is the version currently approved for use by LG&E. It is also the responsibility of the customer to notify LG&E of any changes to existing wiring, equipment, building structure, electrical loading and/or other service requirements that may affect safety or electric system performance.**

The Electric Service Handbook— Customer’s Guide is intended to be a helpful reference for customers and their builders and electrical contractors who are planning a new electrical service within the Louisville Gas and Electric Company (LG&E) service territory. It also details requirements for other types of common electrical work that involves LG&E, such as rewiring work, damage repair and conversions of electric services from overhead to underground. It provides important information on the requirements for temporary and permanent electric service for residential, commercial and industrial installations.

Throughout this book, the term “customer” is used generically to address the party responsible for meeting the service requirement found in this handbook. In reality, the customer’s electrical contractor and/or builder will utilize much of the information in this handbook. However, the customer is ultimately responsible for meeting the requirements outlined in this handbook.

The contents of this handbook are intended to guide the customer through all of the necessary steps to arrange for service. It also contains detailed drawings that cover many of the requirements that must be met before LG&E can provide service. While the information in this book covers the requirements for most common types of new services, it is not intended to cover every LG&E policy and/or standard for service that may apply or provide all of the necessary information needed for complex or special installations. LG&E’s service representatives are available to assist customers and contractors in complying with the requirements of this handbook and to provide any additional support that may be needed to complete complex or other non-standard projects.

LG&E reserves the right to modify the requirements found in this handbook or any other service policy, procedure and/or standard at any time. It is the responsibility of the customer or other responsible party to ensure that any referenced document is the version currently approved for use by LG&E.

LG&E/KU/ODP Service Territories

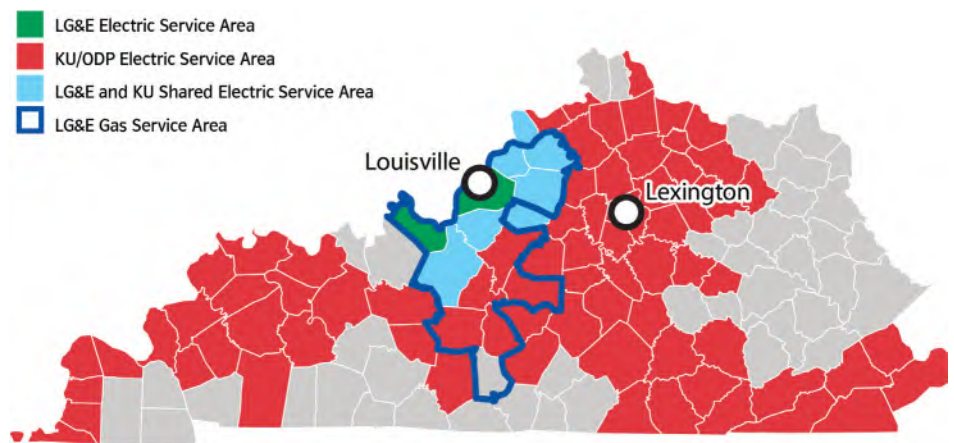

**LG&E Customer Service by Phone 589-1444
(Outside Louisville at 1-800-331-7370)**

ELECTRICAL SAFETY

Safety First—Providing Safe Electrical Service.....	8
Personal Safety	8
Downed or Low Power Lines	8
Lines on Vehicles.....	8
Electrical Safety—A Practical Guide for Children and Adults	9
Electric Safety Tips for Children	9
Making Home Improvements	9
Contractor Safety	10

GENERAL INFORMATION

Important Telephone Numbers.....	12
Service Rates, Rules and Regulations.....	13
Other Sources and Applicable Codes.....	13
Applying For Electric Service.....	14
Service Requirements, Restrictions And Limitations.....	15
Steps For Obtaining New Electric Service	16
Brief Summary Of New Service Process.....	17
Planning for Service	19
Permitting and Inspection Of Electrical Work.....	19
Customer Contributions For Construction.....	19
Customer Information	19
Electric Service Design Parameters.....	21
Available Service Voltages And Configurations.....	21
Choice Of Overhead and Underground Service.....	23
Service Location.....	24
General Metering Information	24
Easements And Clearance Requirements.....	25
Requirements For Electric Service Equipment.....	26
Access and Clearance to LG&E Service Equipment	26
Special Equipment Requirements.....	27

METER INFORMATION

General Requirements.....	29
Obtaining Meter Bases And Associated Equipment	31
Installation Of Metering Equipment.....	31

TEMPORARY AND PERMANENT SERVICE

Temporary Services 600 Volts Or Less.....	38
Temporary Overhead Services	39
Temporary Underground Services.....	40
General Information For Permanent Residential Service.....	42
Grounding.....	42
Motor Restrictions	42

Available Service	43
Permanent Single-Family Residential Electric Services.....	44
Line Extensions	44
Permanent Overhead Residential Electric Services.....	45
Permanent Underground Residential Electric Services.....	46
Mobile Home Services	47
Line Extensions	47
Service Equipment	47
Overhead Services.....	48
Underground Services	49
Multi-Family Structures	51
Line Extensions	51
Special Metering Requirements	51

COMMERCIAL/INDUSTRIAL SERVICES

Introduction	53
Type Of Service	53
Service Voltages	53
Installation Costs.....	54
Number/Type Of Services.....	54
Grounding.....	54
Overhead Services (600 Volts or Less).....	54
Permanent Underground Service (600 Volts or Less).....	55

SPECIAL PROCEDURES

Overhead to Underground Service Conversions.....	58
Conversion Costs	58
Rewire Procedure	59
Burnout Procedure.....	60

SUPPLEMENTAL INFORMATION

Reading Your Own Meter	62
Emergency Power Sources.....	63
Requirements For Emergency and Standby Generators.....	63
Portable Generator Safety.....	63
Landscaping And Vegetation Near Electrical Lines.....	64
Clearance To Overhead Lines.....	64
Tree Safety.....	65
Clearance To Underground Lines.....	65
Planting Near Electrical Equipment.....	66

SERVICE-RELATED DRAWINGS	68
---------------------------------------	----

ELECTRICAL SAFETY



ELECTRICAL SAFETY

Safety First—Providing Safe Electrical Service

The health and safety of our customers and employees is our highest priority. We also believe strongly in the concept that safety is everyone's responsibility. LG&E's employees and contractors will not perform any work in areas considered to be unsafe or install or connect any electrical facilities that are, in the opinion of our employees or contractors, unsafe or not in

compliance with utility requirements or governing codes and regulations. Both LG&E and customer-owned electrical facilities must be planned, designed, built, maintained and operated to minimize the risk of injury and property damage during construction and throughout the operating life of the facility.

Personal Safety

DOWNED OR LOW POWER LINES

At LG&E, we believe in Safety First, and the safety of our customers and the public is important to us. We rely on you to tell us about unsafe conditions, such as downed power lines. Power lines can be brought down by equipment failures or during storms by lightning and high winds, by fallen trees or by other damage such as vehicle accidents. Never touch, move or go near any kind of downed or low hanging line—**even if it looks harmless**.



If you see a downed or low wire **immediately call LG&E at 589-1444 (Outside Louisville at 1-800-331-7370)**. Stay away from the downed or low wires and use extreme caution since

there is no way to know if a wire is an energized electric line or something else like a telephone or cable television line. You don't have to touch a downed line to be seriously injured. You can be shocked just by going too close to a downed line because the earth in the area around the fallen line becomes energized. Even if you do not see sparks, you should assume the line is energized. Always warn others to **STAY AWAY** from downed lines.

If a person is injured, immediately call 911. Then immediately call LG&E at 589-1444 (Outside Louisville at 1-800-331-7370) to report downed lines. NEVER touch downed power lines or try to move a person or object in contact with these lines!

Serious injury and even death can result from coming into contact with a downed electric line. Touching any object, such as a fence, vehicle, building or even a tree that is in contact with a downed or low line, can also injure you. Assume that touching anything near to, or in contact with a downed line is just as dangerous as the downed line itself and stay away.

Remember, be safe! Assume every low hanging or downed line is an energized electric line. Report it as quickly as possible and LG&E will send someone to investigate. Stay away and help keep others away until LG&E arrives and makes the area safe.

LINES ON VEHICLES

Should a fallen line come into contact with a vehicle, the vehicle itself may become energized. In many cases, the safest thing to do is stay in the vehicle until help arrives. Keep others away from the vehicle. Any person attempting to touch or leave the vehicle could be electrocuted. If possible, stay in the vehicle until LG&E has made the line safe. If it is not safe to remain in the vehicle in the event of fire or other danger, **do not step from the vehicle. Jump as far away as possible, keeping both feet together. NEVER touch the vehicle and the ground at the same time.** Hop or shuffle your feet in very small steps to move to safety.



ELECTRICAL SAFETY

A Practical Guide for Children and Adults

With the flick of a switch, you can heat, cool and light your surroundings with electricity. It's so easy that it seems as if electricity could never be any trouble, but care must be taken with this helpful energy we need for everyday living. Safe use of electricity can prevent fires in your home and injuries to you and your family. Here are some tips for all members of your household to follow when using electricity.

Please read and discuss these safety tips with your children, and do not forget to tell them to **"play it safe"** around the house and outdoors by staying away from electrical equipment and wiring. Most importantly, tell them to call an adult immediately if they see any problems with electrical wires or equipment.

Electric Safety Tips for Children

INDOORS

NEVER touch electrical appliances, light switches or anything using electricity if you have wet hands or are standing on a wet surface. Electricity travels through water, and you could be shocked or seriously injured. Keep all electrical devices away from bathtubs and showers.

NEVER stick metal objects in electric outlets or inside appliances or other electrical equipment. Again, you could be shocked or seriously injured.

ALWAYS install electric outlet protectors when small children will be around.

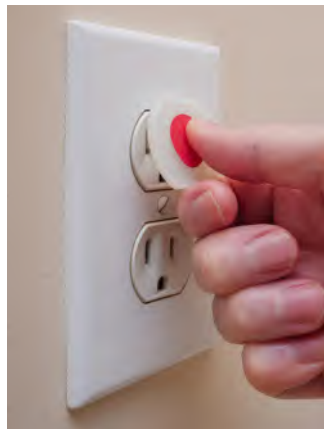

OUTDOORS

NEVER climb or play around trees that are close to overhead lines! If you see a tree limb that is too close to a line, call LG&E to have it removed. If a pet or any animal gets trapped on a utility pole, **call LG&E at 589-1444 (Outside Louisville at 1-800-331-7370)** anytime, day or night, and let us help you. Never try to help the animal yourself!

NEVER climb on or play near the metal or brick fences that surround electrical equipment. The fences around electric substations are there to keep people away for their safety. Never try to get a ball or other object that has fallen inside the fence. Do not reach through or under the fence to retrieve objects. **DO NOT** try to get it yourself. **Call LG&E at 589-1444 (Outside Louisville at 1-800-331-7370)**, and we'll be happy to help.

NEVER fly drones, kites or model airplanes anywhere near overhead lines! Play in parks or other open spaces with no power lines to prevent the danger of severe injury. Even a kite string or toy control wire can carry electricity and cause serious injury should it touch a power line.

Making Home Improvements

Making home improvements—such as adding a garage or a pool to your property—can be a good investment that can add to the value of your home. Before you build, however, you should plan the addition or installation carefully to save yourself time and inconvenience. If you're adding an extension, such as a new room or a screened porch, consider the new roofline carefully. If a power line will come near the completed addition, be sure to call us first. It may be necessary to have the line moved before you begin the project.

If you are thinking about installing a swimming pool, do not build it under electrical lines. If a power line should drop into the pool, you or your family could be injured or killed. Pools should only be built in areas at least 25 feet away from the power line in each direction with at least 17 feet between overhead lines and diving boards, decks or slides.

Also, pools and decks should be installed at least five feet away from all underground lines. Improperly situated pools must be corrected at the customer's own expense or we will be forced to shut off electricity to the home.

If you have further questions, please call us before you begin to build.



Do you work near power lines?

If so, you should be aware that electrocution is one of the top five causes of workplace deaths in the U.S. If you forget about safety precautions or don't know about or understand the risks

involved in the work being done, you or someone you work with could be electrocuted. It only takes one mistake.

Plan ahead before you start work

- Survey the job site carefully before work begins; identify any safety risks and anticipate potential safety problems. Hold a safety and or tailgate meeting each day before work begins at each work site to remind workers what to look out for. Continually warn others about nearby power lines and other electrical hazards. Consider all overhead lines to be energized power lines, no matter what they look like. Note a hazard zone around power lines and stay outside of it.
- If you must work near lines, barricade or otherwise mark the area off and follow all OSHA-required work practices. When working within what could be an unsafe distance to LG&E's electric facilities or that may otherwise be in violation of federal, state or local regulations, the individual(s) must notify LG&E at **589-1444 (Outside Louisville at 1-800-331-7370)**. LG&E will work with the Customer to ensure the work can be performed safely and may cover, de-energize, or temporarily move its facilities in the work area as deemed appropriate to provide a safer working environment, provided reasonable advance

notice is given. While covering lines can make a job site safer, it is not a replacement for safe work practices and is not intended to allow equipment to come too close or contact lines. LG&E reserves the right to recover the cost of any such work when requested by the customer.

- Before digging, call Kentucky **811** to have them coordinate with member utilities to locate and mark underground lines free of charge. Not only will this make work safer, but it also reduces potential costs to repair damage to LG&E's electric and gas lines or those of other utilities. There is no cost to have Kentucky 811 locate underground utilities, but you must call before starting work.
- Report any activities that could damage power poles, such as excavations that might reduce pole stability by calling LG&E at **589-1444 (Outside Louisville at 1-800-331-7370)** before work begins. Temporary bracing may be necessary, and LG&E may impose a charge to cover the cost for any work required.

Keep your distance

OPERATING A BOOM OR CRANE

Don't rely only on ground rods, line covers, warning devices or insulating boom guards to protect you from a power line contact. Instead, designate a person whose only responsibility is to direct you away from power lines.

WORKING WITH POLES, LADDERS OR ANTENNAS

Keep them from reaching or falling into lines by making sure

they clear lines by at least 10 feet in every direction. Under some circumstances, electricity can arc to equipment that is close to a power line, even if it is not touching the line.

WORKING ON THE GROUND

Stand clear of equipment, guide wires and loads that will instantly conduct electricity if they hit a power line. If you're guiding a load, be aware of the location of the crane boom and power lines.

If you hit a power line

- If you're in the equipment, stay there if you can! It is safer to stay in the equipment than to try to get out. Try to move the equipment away from the line. If you can't, stay where you are and wait for rescue workers.
- Have someone call LG&E at **589-1444 (Outside Louisville at 1-800-331-7370)** immediately to shut off the power. Call 911 for medical help if there are injuries. Warn everyone to stay away from the load, guide wires, equipment and anything in

contact with the equipment, all of which could be conducting a deadly amount of electricity.

- If you must get out of the equipment because of fire or other danger, jump free rather than stepping off. Never touch a grounded surface and equipment that is contacting a power line at the same time. Remember that even the ground in the area of a power line contact may carry dangerously high voltage. Hop or shuffle your feet in very small steps to move to safely away.



GENERAL INFORMATION

IMPORTANT PHONE NUMBERS

To Report A Power Outage 502-589-1444

Wire Down, Gas Leak or Other Dangerous Condition (24-Hrs.)

Outside Louisville 1-800-331-7370

Customer Service 502-589-1444

Outside Louisville 1-800-331-7370

LG&E's Customer Service Walk-In Center Is located at
701 South Ninth Street (corner of 9th and Broadway)

METER INFORMATION AND SERVICES (8 a.m. - 5 p.m.)

Meter Reading Appointment Time 627-2280

Service Order Appointment Time and Dispatch 627-2275

Meter Tampering Investigation 627-2460

LG&E Electric Meter Shop 364-8270

(Meter Base pick-up 8 a.m. - Noon)

REGIONAL ELECTRICAL INSPECTION AGENCIES

(Area code 502 unless otherwise noted.)

State Fire Marshall 573-0382

Metro Louisville 574-3321

Jeffersontown 267-8333

Tri-County

Trimble Co. and Carroll Co. 255-4667

Henry Co. and Lagrange 241-4235

Bullitt County 955-4034

Hardin, Meade Co. and West Point (270) 769-5479

Oldham County 222-3967

Shelby County 829-0054

Spencer County 477-9135

KY Electrical Inspectors Office 573-0365

OTHER IMPORTANT NUMBERS

Kentucky Dig Safely 811

Call Kentucky 811 (dial 811) to determine the location of existing underground utilities that may interfere with your installation. Please call at least two working days and not more than ten working days prior to your planned excavation.

GENERAL INFORMATION

Service, Rates, Rules & Regulations

All electric service supplied by LG&E is provided in accordance with the applicable rates, rules and regulations of the Kentucky Public Service Commission (KPSC), psc.state.ky.us and Louisville Gas and Electric Company lge-ku.com

The administrative rules of the KPSC can be found in the document **Kentucky Administrative Regulations Pertaining to the Kentucky Public Service Commission, Title 807, and Chapter 7 - Utilities**. This document is available for public inspection at the Commission, on the KPSC Internet site (above), at LG&E's Customer Service Center at 701 South Ninth Street in Louisville, Kentucky, and also at the LG&E Internet site (above). This document establishes general rules and regulations for all types of public utility service (water, gas, electric, telephone, etc.) that falls under the jurisdiction of KPSC. Specific sections of this document apply to electric service.

LG&E's rates and requirements for electric service are documented in **Louisville Gas and Electric Company Rates, Rules and Regulations for Furnishing Electric Service**. This document can be found at each of the same locations as the KPSC administrative regulations. This document sets out specific rates and requirements for electric service provided by LG&E within the defined LG&E service territory.



LG&E provides electric service to all new residential customers under a single rate plan, the Residential Rate R. Non-residential Customers will be placed in one of several different customer plans depending on factors such as expected peak demand and other characteristics of use. The rates and chargeable energy components for non-residential service plans vary by the class of service, and in some cases, by the service voltage provided and even the time of use. Each class of service will also have different service restrictions and customer requirements. LG&E's service representatives will work closely with customers to determine the appropriate rate plan and all other necessary service parameters. This will ensure new customers are placed on the most cost-effective rate plan available for their service size, voltage and characteristics of use.

Other Sources and Applicable Codes

NATIONAL ELECTRICAL SAFETY CODE (ANSI C-2)

The NESC® covers work practices and requirements for electric supply facilities under the control of public and private utilities and certain other similar systems under the control of qualified persons, such as those associated with a large industrial complex. The NESC® covers the requirements for utility systems up to the Point Of Delivery. The NESC® also covers street and area lighting under the exclusive control of utilities or other qualified employees operating similar systems. (IEEE Service Center, 445 Hoes Lane, P.O. Box 1331, Piscataway, New Jersey 08855-1331.)

NATIONAL ELECTRICAL CODE (ANSI-NFPA 70)

The NEC® covers, in general, the design, alteration, modification, construction, maintenance and testing of utilization (i.e. non-utility) wiring and equipment, including certain utilization wiring of a temporary nature. The NEC® code generally covers all aspects of utilization wiring beyond the Point Of Delivery. (National Fire Protection Association, Batterymarch Park, Quincy, Massachusetts 02169.)

KENTUCKY BUILDING CODE

This document establishes rules that are intended to establish a uniform building code in the state of Kentucky (Department of Housing, Buildings and Construction) dhbc.ky.gov

GENERAL INFORMATION

Applying For Electric Service

The first step in arranging for new service is to contact LG&E and make an application for service. LG&E cannot begin the process of arranging for service until the application for service has been accepted. To avoid unnecessary delays in receiving service, please make your application for service as far in advance as possible of the date service is required. LG&E will require sufficient time to design, plan and install the necessary electrical facilities for new services. Additional time will be required if LG&E must extend or enhance facilities to provide service.

Requests for new temporary and permanent residential, commercial and industrial services can be made online at lge-ku.com, by phone through Customer Service (residential services) or the Business Service Center (commercial/industrial services).

For Residential Services, contact:
Customer Service(502) 589-1444
(Outside Louisville)**1-800-331-7370**

For Commercial/Industrial Services, contact:
Business Service Center (502) 627-3313
(Outside Louisville)**1-800-331-7370**

At the time an application for new electric service is made, the customer should be prepared to provide the following:

- ▶ Name(s) on the account
- ▶ Responsible parties' Social Security Numbers
- ▶ Service address (city, street address and zip code)
- ▶ If the service is for a home, and the home will be constructed in a subdivision, you will also need to provide the subdivision name and lot number
- ▶ Current home and work telephone numbers
- ▶ Expected in-service need date for new service
- ▶ Temporary service requirements (if necessary)

Special Notes:

- If both temporary and permanent electric service is needed at the same site, separate applications must be completed. However, both applications can be made at the same time and the process is the same as applying for permanent service. See the section on Temporary Electric Service.
- If a gas service is also required, it will be necessary to request a gas service at the same time an application for electric service is made.
- The submission of an application for service constitutes the customer's permission for LG&E to conduct a credit history check.

At the time an application for service is made, the customer will be given an account and/or order number. This information should be retained for the purpose of tracking the progress of the service request. The customer will also be given contact information for an LG&E service representative called a Service Locator.

LG&E's Service Locator will be the customer's primary contact and will guide the customer through all of the necessary steps to acquire service.



GENERAL INFORMATION

Service Requirements, Restrictions And Limitations

Certain restrictions and limitations apply for establishing and maintaining electrical service. Below is a partial list of some of these restrictions and limitations.

CONTRACT ACCEPTANCE AND TERMS

LG&E has the right to reject, **for valid reasons**, any application or contract for service.

Applications for electric service are not transferable, and new occupants of premises are required to make an application for service before service is provided. Customers who have been receiving electric service must notify LG&E when they wish to discontinue service and are responsible for paying for all electric service furnished until the time a request to discontinue service has been made.

LG&E may require a minimum cash deposit or other guarantee to secure payment of bills. Service may be refused or discontinued for failure to pay the required deposit. For more information regarding LG&E's deposit policy, contact Customer Service.

USE OF SERVICE RESTRICTIONS

Customers are prohibited from using an electric service for purposes other than those set forth in the customer's application or contract. All of the customer's equipment, apparatus and appliances must have such characteristics or be equipped with corrective devices to enable LG&E to maintain a satisfactory standard of service.

Electric energy furnished under LG&E's standard application or contract is for the use of the customer only. No customer shall resell such energy to any other person, firm or corporation without the written consent of LG&E and approval of the KPSC.

REFUSAL OR DISCONTINUANCE OF SERVICE

In accordance with and subject to the rules and regulations of the KPSC, LG&E retains the right to refuse or discontinue service to an applicant or customer under certain conditions. LG&E will charge the customer for disconnections and reconnections of electric service resulting from non payment of bills, unsafe conditions or for violations of the company's rules and regulations. Refusal or discontinuance of service with or without notice, and without liability, can occur under various other circumstances. These conditions are set forth in LG&E's Tariffs filed with the KPSC and the rules and regulations of the Commission.

Since it is LG&E's obligation to provide safe and satisfactory service to all customers, LG&E reserves the right to refuse or discontinue service without notice if, in the opinion of LG&E, the customer's wiring, equipment or appliances are unsafe or unsuitable for receiving electric service or are harmful to the service of other customers. LG&E will make a reasonable effort to notify the customer prior to disconnection and shall inform the customer of the steps, which must be taken to have service, restored.

COST OF TEMPORARY SERVICE

The customer is required to pay the entire cost of all material, labor and expenses incurred by LG&E associated with supplying electric service for any temporary, short-term use, or intermittent loads, including seasonal or infrequently used loads.

SERVICE AND LIABILITY LIMITATIONS

LG&E is not liable for any injury or damage to persons or property resulting from the presence, use or abuse of electricity on the customer's premises. LG&E shall be held harmless for any injury or damage to persons or property resulting from defects in customer wiring, equipment, apparatus, or appliances or resulting from any cause whatsoever other than the negligence of LG&E.

LG&E will exercise reasonable care and diligence in an endeavor to supply service continuously and without interruption, but LG&E does not guarantee continuous service. It is the responsibility of the customer, when deemed necessary or desirable, to install any equipment necessary to protect the facilities against disruptions in service, including complete or partial loss of service (lost phase), voltage surges, over/under voltage conditions, etc.

LG&E shall not be liable for any loss or damage resulting from interruption, reduction, delay or failure of electric service not caused by the willful negligence on the part of LG&E, or resulting from any cause or circumstance beyond the reasonable control of the company. Disruptions considered beyond the control of the utility include, but are not limited to, outages resulting from storm conditions, lightning, interference by animals, unanticipated equipment failures, tree contacts, high water conditions, public interference (such as vehicle accidents, vandalism, etc.), failure of customer equipment, etc. LG&E is also not liable for any loss of service resulting from the need to de-energize lines and equipment without notice to allow employees and/or its contractors to safely perform work or to respond to emergencies.

CUSTOMER ELECTRICAL LOADING AND ENERGY USE RESTRICTIONS

LG&E reserves the right to place restrictions on the type and manner of use of all customers' electrical equipment. Examples of loads that may be restricted include loads too large for the service ratings, highly fluctuating loads and other offending loads such as those with objectionable harmonic levels or characteristics otherwise detrimental to LG&E's electrical system or its ability to provide acceptable service to other customers. When necessary, LG&E will require the customer to remove or correct any unacceptable loads at their own expense.

LG&E's service connections, transformers, meters, and associated equipment used to provide service have definite

GENERAL INFORMATION

capacity limitations and can be damaged by changing service requirements, especially increased loading requirements which can overload utility equipment. Therefore, the customer must notify LG&E prior to increasing loading requirements or making any other alterations to the service entrance equipment that could affect utility equipment. Failure to properly notify LG&E of such additional requirements could result in damage to the customer's and/or LG&E facilities resulting in unexpected service interruptions and delays in restoring service while repairs are made. Customers may also be subject to charges by LG&E for corrective actions required to restore the utility's system and for damage to other customers' facilities.

The customer will not be permitted to install wiring or connect any device that is detrimental to the LG&E electric system or to the service of other customers. LG&E will assume no responsibility for the customer's electrical wiring or apparatus or for the maintenance or removal of any portion thereof.

The Point Of Delivery for electrical energy supplied by LG&E shall be at a service point designated by LG&E. At this point, LG&E's facilities are physically connected with the facilities of the customer. Metering points seldom but may differ from this location. The Point Of Delivery varies by the characteristics of the service and whether the service is provided overhead or underground.

The customer is responsible for furnishing, installing and maintaining all electrical apparatus and wiring to connect with LG&E's electric service facilities. All customer wiring and equipment shall be installed and maintained in conformity with applicable codes and the rules and regulations of the Inspection Authority having jurisdiction.

Steps For Obtaining New Electric Service

A summary of the steps involved to complete the new service process can be found below. The steps cover all customer/contractor responsibilities from service application to preparing

for service. More detailed information on planning for service and detailed standards for service requirements follow this section. A brief summary of the work LG&E will perform is also provided.

Quick Steps Check List

To Complete The New Service Process A Customer Must:

1. Contact LG&E to apply for service (This step must be completed first.)
2. Contact the appropriate LG&E Service Locator to obtain a service location and electric meter location.
3. Provide detailed load information and a copy of the site plan for all commercial or industrial services.
4. Sign a service contract and pay any amount due in customer contribution (if required). No work can be performed before this is done.
5. Obtain a permit for electrical work from the appropriate Electrical Authority and have all work inspected and approved once completed.
6. Install all required customer facilities provided for LG&E's use according to company standards and notify LG&E when these facilities are ready for approval.
7. Convey to LG&E all necessary Rights-of-Way.

GENERAL INFORMATION

Brief Summary of New Service Process | Customer/Contractor Steps

1. Customer must contact LG&E to apply for service.

Visit our website at www.lge-ku.com or call:

For Residential Services:

Customer Service (502) 589-1444

(Outside Louisville)..... 1-800-331-7370

Mon. – Fri. (7 a.m. – 7 p.m.)

For Commercial/Industrial Services:

Business Service Center (502) 627-3313

(Outside Louisville)..... 1-800-331-7370

Mon. – Fri. (7 a.m. – 6 p.m.)

All requests for new temporary and permanent residential, commercial, and industrial services MUST be made through Customer Service (residential services) or Business Service Center (commercial/industrial services). At the time of requesting service, LG&E must be given a valid address. Please provide ALL available information (street name, house

number, lot number, etc.). If the site will need gas service, the applicant must let the service representative know at this time. The customer should:

- Retain account and/or order number for future reference.
- Provide the best known need date for service.
- Obtain the contact information for the LG&E Service Locator for the service area.

Application for a temporary service and a future permanent service at the same location can be made at the same time even though they are processed as two separate service applications.

Note: Customer must contact LG&E to apply for service before applying for city/county inspection by either the owner or the responsible builder/contractor.

2. Customer must work with the appropriate LG&E Service Locator to receive an electric service and meter.

EXCEPTION: A service location will not be required for temporary and permanent 120/240V 1-phase 3-wire services, less than 300A, provided to single-family homes in dedicated underground subdivisions where underground facilities have been pre-installed by LG&E. In these installations, it is practical for the contractor/builder to identify all of the service parameters, including the service entrance/meter location for temporary and permanent service from the information

provided in the standard drawings in the back of this handbook. **See Drawing # 52 01 06 for permanent underground service requirements and # 52 10 02 for temporary underground service requirements.** It is the contractor’s responsibility to contact the LG&E Service Locator for unusual construction requirements and/or when there is any confusion as to where the service entrance equipment should be located or where the customer’s underground service conductors should terminate.

3. Customer must provide detailed load information and two copies of the site plan for all commercial or industrial services (Commercial and Industrial Customers Only).

Load data must be provided on LG&E’s Electrical Load Data Submittal Sheet. A copy of the electric data submittal form can be found in this handbook, and both gas and electric

forms can be requested from the LG&E’s Service Locator. Completed forms should be returned to the LG&E Service Locator.

4. Customer must sign a service contract and pay any amounts due in customer contributions (if required) before any work can be performed.

5. Customer must obtain a permit for electrical work and have all work inspected and approved.

The Kentucky Uniform Building Code requires the electrical inspection of all new buildings before service is connected. After service has been requested, the electrical contractor or responsible party should contact the appropriate Inspection Authority having jurisdiction in their area to arrange for the inspection and approval of all electrical work.

When the Authorized Inspection Authority has approved electrical work, a green approval sticker will be posted at the job site. LG&E must be notified of the approval by the Authorized Inspection Authority before the work to energize the service can be scheduled. LG&E cannot energize the service if there is no approval sticker in place.

GENERAL INFORMATION

6. Customer must have installed all LG&E required-customer provided underground facilities and notify LG&E when these facilities are ready for inspection. (Commercial and Industrial Customers Only)

LG&E requires commercial and industrial customers to provide certain service facilities on private property for use by LG&E. This includes items such as underground duct, equipment pads, manholes, etc. that may be required to provide service. These facilities must be constructed to LG&E's standards. Following acceptance of the completed facilities by LG&E,

control of these facilities is transferred to LG&E; however, the customer continues to own and be responsible for any necessary maintenance of these facilities. These facilities must be completely installed, inspected and approved by LG&E before service work can begin.

7. Customer must obtain a permit for electrical work and have all work inspected and approved.

The customer must convey to LG&E all necessary rights-of-way on the customer's property required for LG&E to place

facilities and provide service. Any rights-of-way needed from other property owners will be obtained by LG&E.

8. Customer must provide a centerline drawing for underground commercial/industrial services which completely describes the location of customer provided facilities and any easements granted on the customer's property. (Commercial and Industrial Customers Only)

LG&E's Service Locators will work with customers to finalize the location of all LG&E electric facilities on the customer's property. It is the customer's responsibility to provide detailed survey information, including bearings and calls for any underground facilities provided by the customer for LG&E's

use as well as any easements granted to LG&E for the extension of electric facilities. Facility and easement information need not be provided for any sections parallel to a property line provided a detailed property record plat has been provided.

Brief Summary of New Service Process | LG&E Steps

1. LG&E will design the utility service and provide the customer with any necessary documents related to the service for use by the customer, including design and construction drawings, forms, standards, etc.

2. LG&E will work to obtain all necessary permits from public entities for the installation of LG&E facilities in public way. LG&E will also obtain all work permits required to perform work in public way associated with providing service to the customer. LG&E will obtain all necessary easements required from other property owners, if applicable.

3. LG&E will install all required utility service facilities and energize the service once all of the above customer and contractor requirements have been met and LG&E has been notified that the Authorized Inspection Authority has approved all work.

GENERAL INFORMATION

Planning for Service

The following sections provide some general information that customers should consider when designing and preparing for electrical service. More comprehensive information about many of the topics discussed below can be found elsewhere in this manual.

PERMITTING AND INSPECTION OF ELECTRICAL WORK

In the majority of the territory served by LG&E, local electrical inspection authorities have jurisdiction for determining the safety and suitability of customer-owned electrical systems. LG&E works closely with these agencies to ensure that electrical service can be provided and used safely. See the telephone listings near the front of this section for a list of inspection agencies.

All new customer-owned electrical systems must be inspected and approved by the appropriate Authorized Inspection Authority before LG&E will energize a service.



LG&E also requires an inspection of existing services when they have been disconnected for any safety reason, been repaired, expanded or otherwise modified or have been inactive for more than one year. LG&E can also require a re-inspection of a service at any time if, in the opinion of LG&E, providing electrical service has created or could create an unsafe condition. The customer must arrange to have a licensed electrical contractor complete any necessary work and have the facility re-certified by the appropriate Inspection Agency. Service restoration cannot occur until the Authorized Inspection Agency notifies LG&E of its approval of the electrical facilities.

CUSTOMER CONTRIBUTIONS FOR CONSTRUCTION

In accordance with the tariffs, customers are responsible for all costs associated with temporary services. In almost all cases, customers will also be responsible for all costs associated with serving seasonal, temporary or lightly used services.

Customers may also be responsible for some or all of the cost for permanent service. In many cases, LG&E can provide permanent electrical service from existing facilities in the area with little or no cost to the customer. Sometimes, however, LG&E must extend electric lines to provide service. Extensions of LG&E's facilities to serve a new site are made in accordance with the provisions of the company's Rates, Rules and Regulations for Furnishing Electric Service. The portion of such extensions that LG&E will furnish at its cost depends on the service type, the size and type of loads and the type of LG&E's facilities available at the service location. LG&E's service representatives will inform the customer of any service-related costs.

LG&E is obligated to provide service to each customer in the least-cost manner. The customer is responsible for the incremental cost of any service request that exceeds the minimum standard or results in any increased cost to serve. This includes most requests for underground service, requesting service at locations other than the one specified by LG&E, changes in specified service voltage, etc. LG&E's service representative will notify the customer of any additional charges.

LG&E is not obligated to begin design or construction work until the customer has signed a contract for service. The contract sets out terms and conditions for service and obligates a customer to pay for electrical service and any other service-related costs before construction begins. No service or metering equipment can be installed until this step is completed.

CUSTOMER INFORMATION

To avoid unnecessary delays and/or costs, it is critical that the customer apply for service and notify LG&E of service needs as soon as practical. Shortly after applying for service, an LG&E service representative will begin working with the customer to gather information and finalize the necessary service parameters. LG&E determines the type of electrical service provided based

on a combination of the customer's needs (service size/type/voltage), characteristics of use and the electrical facilities LG&E has or can reasonably make available at the service location. The information LG&E requires the customer to provide varies by the type of service requested. Below is a typical listing of electrical service information that LG&E requires.

GENERAL INFORMATION

Planning for Service *(continued)*

RESIDENTIAL CUSTOMERS

The Residential class of service is largely restricted to service for single-family units for lighting, heating/cooling, cooking, refrigeration and other common purposes typical of domestic use. After an application for service is made, an LG&E service representative will contact the customer to determine any required service parameters. The customer needs to be able to provide the following information:

- Planned electrical entrance size (in amps)
- Type of service requested (overhead or underground)
- Type of heating (electric heat, electric heat with heat pump or gas)
- Size and, if appropriate, number of A/C units (specified in tons of cooling)
- Type of major cooking appliances (gas or electric)
- Type of water heater, tank or tankless (gas or electric)
- Other large loads (large tools or appliances, pools, hot tubs, saunas, etc.)

Residential services are not designed nor intended to provide service for unconventional or high demand equipment such as “on demand” water heaters or other intermittent, high demand

or frequently started devices such as welders, large motors, etc. If any such equipment interferes with service to other customers or if LG&E cannot adequately serve these loads, the customer will have to remove the equipment at their expense. Additionally, the customer is responsible for any costs associated with upgrading LG&E facilities to serve any unconventional equipment or loads.

Residential services have maximum starting current restrictions that apply to motors, compressors and other devices that have large starting currents, including HVAC units and associated equipment. **Maximum Locked Rotor (inrush) current is restricted to 125 amps at 240 volt and 50 amps at 120 volts.** These restrictions apply to all motors and other associated equipment arranged for simultaneous starting. Large A/C units or other large motors, compressors, etc. may require supplemental starting equipment to ensure inrush currents do not exceed these values. The customer is responsible for any costs associated with making corrections to the equipment, upgrading LG&E’s service or, if required, removing offending loads if they exceed the above values.

COMMERCIAL AND INDUSTRIAL CUSTOMERS

For commercial and industrial services, the following information must be provided before LG&E can begin planning to provide service:

1. Service size, design loads and voltage requested. This information should be submitted on LG&E’s “Electrical Load Data Submittal Sheet”. A sample of this form is provided in Drawings section of this publication.

Load type and size information can usually be provided well before electrical system plans are completed. Because this form contains information used to determine electrical energy requirements, someone experienced in making such assessments should complete it. LG&E uses the information to prepare the utility system design and specify equipment for your project. Early completion of this requirement is critical for providing service in a timely manner. Design work cannot begin and equipment cannot be ordered until detailed loading information is provided.

2. Site plan for the facility being served (two copies).

LG&E’s Service Locators use site plans to finalize location of all LG&E electric facilities on the customer’s property.

The site plan should indicate all rights-of-way and/or easements, property lines, streets, electric/gas/water utility lines, building layouts, streams, future buildings, pools, decks, buried objects or other obstructions or facilities that may affect electric service. LG&E uses this information to design and construct the facilities necessary to provide safe and reliable service. For LG&E to complete its design, the customer must stake all property corners so that the Service Locator can locate easements and/or service routes.

LG&E requires additional information when providing underground service. The customer must provide detailed survey information, including bearings and calls, for any underground facilities provided by the customer for LG&E’s use as well as any easements granted LG&E for the extension of electric facilities. Facility and easement information need not be provided for any sections parallel to a property line provided a property record plat has been provided to LG&E that contains this information. If appropriate, the Service Locator will return one copy of the site plan to the customer approving the electrical service arrangement or detailing any required changes.

GENERAL INFORMATION

Electric Service Design Parameters

When planning a new service, many decisions need to be made before LG&E can begin the process of providing service. Some decisions, like service voltage for commercial and industrial customers, must be decided in conjunction with LG&E. Other decisions, such as service size, number of phases and whether to request service overhead or underground will usually be made based on customer needs and preferences.

LG&E will provide each customer with a single-service voltage/configuration and will provide this service to a single location at the facility. Customers provided three-phase service is expected to provide any necessary voltage transformation needed for lighting and outlet loads. At LG&E's discretion, a single-phase lighting service may be provided to three-phase power customers taking 240 volt or 480 volt 3-phase, 3-wire service.

The decisions that have to be made by new residential customers are relatively easy. There is only a single service offering, 120/240 volt 1-phase 3-wire service up to 800 amps, unless otherwise approved by LG&E. The customer must only decide whether to request the service be provided underground or overhead. If the new home is in an established underground residential

subdivision, then service will be provided underground. In other cases, either type of service can usually be provided although there may be additional costs involved if underground service is requested.

The service choices for commercial and industrial customers are more complex. There are more service voltages and wiring configurations available, but the type of service provided may be restricted by loading requirements and/or by LG&E's existing facilities available near the service location. When reasonable, LG&E provides service from existing electric facilities when existing facilities are appropriate and have adequate capacity or can easily be upgraded to have the required capacity. If existing facilities cannot provide adequate service, the customer can request a specific service voltage and wiring configuration (3-wire, 4-wire, etc.) but the final determination of all service parameters will be made by LG&E. Therefore, commercial and industrial customers must work closely with LG&E's Service Locators to determine service parameters before beginning their electrical system design. See "Available Service Voltages and Configurations" below for additional information.

AVAILABLE SERVICE VOLTAGES AND CONFIGURATIONS

GENERAL INFORMATION

LG&E supplies only alternating current service with a nominal frequency of 60 cycles per second at the voltages identified below.

While residential customers will be provided with a single-service offering, commercial and industrial customers can generally be served from one of several voltage offerings subject to the restrictions found in the preceding section. Commercial and industrial customers can choose to be served at secondary voltage levels, which are typically considered to be 480 volts and below for LG&E's customers. Customers can also choose to be served at primary voltage levels up to 34,500 volts. Transmission voltage service up to 345,000 volts is available to LG&E's largest industrial customers.

Each service voltage class (secondary, primary and transmission) offers different benefits and different sets of customer requirements and responsibilities. Service at secondary levels is a bit more costly than service taken at either primary or transmission levels. However, it places the least burden on the customer in terms of equipment and maintenance costs. The customer does not have to own or maintain high voltage lines or equipment and is not responsible for the equipment necessary to transform high voltage to usable levels. If a service is provided overhead, the service lines are brought right to the building at a usable voltage level. (If service is provided underground, the customer is responsible for the low voltage service lines to the building.)

When service is provided at primary or transmission levels, the customer's monthly utility costs are less, but the customer's equipment installation and maintenance costs increase. LG&E brings high voltage lines to the customer's property, but terminates its high voltage lines at or near a property line. The customer is responsible for providing and maintaining all high and low-voltage facilities beyond this point, including transformation and protective equipment.

Choosing a class of service voltage is an important decision for commercial and industrial customers. It is one of the first decisions to be made because it significantly affects the electrical system design for both the customer and LG&E. The customer must carefully weigh the benefits and disadvantages, both financially and operationally, of the different service offerings. LG&E Service Locators are available to help customers understand the costs, benefits and limitations involved with each service voltage level.

Unless expressly authorized by LG&E, no temporary or permanent electrical work should start until LG&E has determined the service size, voltage, wiring configuration and metering requirements. LG&E is not responsible for any delays, reconstruction work or additional cost incurred by customers or their contractors/builders if work is started before all of the necessary service parameters have been finalized.

GENERAL INFORMATION

Electric Service Design Parameters *(continued)*

SINGLE-PHASE SERVICE VOLTAGES

Customers requesting the residential class of service will be provided with 120/240 volt single-phase, 3-wire service up to a maximum of 800 amps unless otherwise approved. All new residential services are now required to be a minimum of 100 amps. LG&E no longer provides 120 volt 2-wire service for any customer class. Single-phase service for any non-residential purpose will fall under another class of service. LG&E's standard 120/240 volt single-phase service is available throughout LG&E's electric service territory and can be provided from either overhead or underground lines.

See chart at right for single-phase offerings are available.

SINGLE-PHASE SECONDARY SERVICE VOLTAGES	APPLICATION
120/240 volt 3-wire	Residential and commercial services
240/480 volt 3-wire	Overhead service only for non-residential customers

THREE-PHASE SERVICE VOLTAGES

Besides being restricted by the presence of existing service equipment, voltage offerings provided by LG&E may also be restricted based on the size of the service requested and/or the characteristics of the load being served. LG&E retains the right to designate the service voltage and configuration based on the availability of facilities of adequate capacity and type at the service location.

The three-phase secondary voltages shown below are generally available throughout LG&E's service territory but may be restricted to either overhead service only or underground service. Not all primary and transmission voltages are available in all parts of LG&E service territory.

See chart at right for standard LG&E service offerings.

THREE-PHASE SERVICE VOLTAGES	APPLICATION
Secondary	
120/208 volt 4-wire grounded wye	Service from either overhead or underground
240 volt 3-wire, corner grounded delta	Service from overhead service feeds only
277/480 volt 4-wire grounded wye	Service from underground service only
480 volt 3-wire ungrounded delta	Service for motor loads only
Primary	
2,400/4,160 volt 4-wire grounded wye	Restricted Service Area
7,200/12,470 volt 4-wire grounded wye	Restricted Service Area
13,800 volt 3-wire impedance grounded delta	Restricted Service Area
34,500 volt 4-wire grounded wye	Restricted Service Area
Transmission	
69,000 volt 4-wire grounded wye	Restricted Service Area
138,000 volt 4-wire grounded wye	Restricted Service Area
345,000 volt 4-wire grounded wye	Restricted Service Area

GENERAL INFORMATION

Electric Service Design Parameters *(continued)*

CHOICE OF OVERHEAD AND UNDERGROUND SERVICE

Because LG&E is required by the KPSC to provide service in the least-cost manner, service will typically be provided from overhead electric lines and equipment where available unless there is some benefit to LG&E to do otherwise.

When underground service is specifically requested by a customer and the cost to provide overhead service would be less, the customer is responsible for the difference in cost between underground and overhead service. LG&E also reserves the right to restrict the type of service to either overhead or underground

service when circumstances necessitate it. For example, underground service may be prohibited in areas subject to flooding and overhead service may be limited at facilities where service cannot be provided safely or reliably from overhead lines and equipment.

While the customer installs, owns and maintains the underground service and is free to choose the method of installation, LG&E strongly encourages customers to install all underground service conductors in approved conduit to avoid damage, to extend life of the cable system and to facilitate replacement when necessary.

OVERHEAD SERVICES

When providing secondary service overhead, LG&E typically brings service conductors to the home or facility being served although service can be terminated at a customer-owned pole or structure. Service lines will be terminated at a location designated by LG&E. In overhead installations, LG&E installs, owns and maintains these service conductors all the way to the home or facility including the electrical connections made at the service entrance. LG&E is responsible for connecting the customer's wiring to LG&E's service conductors at the service entrance. The provisions for attaching the service lines to the building or structure are provided by the customer to LG&E's approved standards. The customer is responsible for all wiring and equipment beyond the weatherhead

with the exception of the electric metering devices.

For industrial and commercial customers taking overhead service at higher voltages, special requirements apply. LG&E will terminate high-voltage overhead lines at or near a property line. Metering equipment will generally be located at or near this point. Beyond this point, the customer is responsible for the distribution and transformation of electrical energy. The customer will provide, own and maintain all electrical equipment, structures, lines and cable systems beyond this point. For additional information, see the section above, "Available Service Voltages and Configurations."

UNDERGROUND SERVICES

Underground Residential Service

When secondary service is provided underground to residential customers, LG&E normally brings its electric service lines to a point at or near the customer's property line. LG&E will not extend a service line to the home as it would for an overhead service. LG&E places either a service enclosure or a transformer on each lot to provide service. The Point Of Delivery will be at the connection point at the transformer or in the service enclosure. LG&E is responsible for connecting the customer's wiring to utility equipment and/or service conductors. Beyond this point, the customer is responsible for installing and maintaining the service conductors and all other wiring and equipment with the exception of electric metering devices. Sometimes it will be impractical to provide adequate service from near the property if the distance between the property line and the home is great and LG&E will have to extend lines onto the customer's property and place a transformer closer to the home. The customer will be responsible for the additional cost to extend underground lines onto the customer's property and must grant an easement for these facilities.

must grant an easement and provide all conduit systems, manholes, splice boxes, enclosures, equipment pads and other associated facilities necessary for LG&E to extend service onto the property. These facilities must be constructed in strict compliance with LG&E standards. While the customer provides and maintains these facilities, these facilities remain under the exclusive control of LG&E and may not be accessed or modified in any way without prior authorization by LG&E. No facilities from other utilities may be placed in manholes, splice boxes, enclosures, conduit systems, etc. that are provided for LG&E's use. However, LG&E may allow the customer to place other cable systems in a common trench adjacent to LG&E's conduit system provided the cable systems do not enter manholes, splice boxes, enclosures or conduit systems under the control of the utility. **Water and sewer piping will not be allowed in a common trench.**

For industrial and commercial customers taking underground service at higher voltages, special requirements apply. LG&E will terminate high-voltage cables at or near the property line. Metering equipment will generally be located at or near this point. Beyond this point, the customer is responsible for the distribution and transformation of electrical energy. The customer will provide, own and maintain all electrical equipment, structures, lines and cable systems beyond this point. For additional information on primary services, see the section above titled "Available Service Voltages and Configurations."

Underground Commercial and Industrial Secondary Service

It is seldom feasible to provide service to Commercial and Industrial customers from the property line and LG&E must extend its facilities onto the customer's property. When this is necessary, the customer

GENERAL INFORMATION

Electric Service Design Parameters *(continued)*

DOWNTOWN LOUISVILLE NETWORK SERVICE

By ordinance of the City of Louisville, LG&E is required to provide service in a well-defined but limited portion of downtown Louisville from underground facilities when service is taken from the front of the building. This area is defined as the downtown “Ordinance” area. LG&E will choose the method of providing service underground in this area. Due to the complex nature of providing service in this area, customers establishing such

service must work closely with their LG&E service representative. Special equipment and customer requirements may apply.

There is no additional cost to the customer for basic underground service in the downtown ordinance area; however, the customer may be required to provide an equipment room or below grade vault in order to accommodate the supply equipment.

SERVICE LOCATION

Regardless of whether service is provided overhead or underground, at secondary or primary voltage, etc., LG&E designates the location on the property or on the facility where service will be taken. For overhead services, the service location will usually be the corner of the house or building closest to the LG&E lines where the service will originate. For underground services, this point is normally an enclosure or a piece of equipment somewhere near the property line closest to LG&E’s service lines or equipment unless LG&E has to extend facilities onto the customer’s property in order to provide adequate service.

Overhead service entrances must be located where service can be provided without having to cross over or under another structure, swimming pool or property not owned by the customer. They must also be located to facilitate proper connections and to provide adequate clearances over roads, drives, structures and the

building being served in accordance with the latest revision of The National Electrical Safety Code (NESC®) and National Electrical Code (NEC®). Underground services must be located such that there are no conflicts with other utilities or other structures, such as buildings or swimming pools.

The meter base should be located on the facility in an accessible location at the point closest to the service entrance unless approval is given to locate the metering equipment elsewhere. For additional information on metering requirements, see Part 2 “Metering Requirements.”

LG&E’s Service Locator will work with the customer to determine the appropriate location for the service entrance and metering equipment.

GENERAL METERING INFORMATION

Because metering requirements can be somewhat confusing and complex depending on the service size/type, a separate section of this handbook, titled Metering Requirements, contains specific information on metering. Standards drawings detailing metering installations can be found in Drawings section of this handbook.

In general, every service installation will require one or more electric meters and the associated meter base(s). The customer is responsible for installing the meter bases. LG&E provides and installs the electric meter(s) once the service is ready to be energized. The customer is responsible for providing and installing most meter bases. For additional information on meter base requirements, see Part 2 “Metering Requirements”.

Regardless of who provides the meter base, the customer installs, owns and maintains the base and other required enclosures for the life of the system. However, the base is considered to be under the exclusive control of the utility as long as the service exists. The meter base will be sealed by LG&E and access to the meter base is prohibited without authorization.

In addition to meter base requirements, customers may be required to provide additional enclosures and associated equipment for larger single-phase and three-phase services, which require instrument rated metering. All enclosures required to house the special metering equipment and other associated equipment, such as connectors, by-pass switches, conduit, structural supports, pads, etc. will be provided, owned and maintained by the customer; they must nonetheless be approved for use by LG&E before installation.

Like meter bases, all metering enclosures, compartments and other associated equipment will be sealed by LG&E and access to these areas without authorization is prohibited.



GENERAL INFORMATION

Electric Service Design Parameters *(continued)*

EASEMENTS AND CLEARANCE REQUIREMENTS

GENERAL INFORMATION

LG&E obtains easements whenever it is necessary to locate electric supply lines or equipment on private property. The location of these easements can affect the service location and the cost of the installation. Easements give LG&E the right to access, construct, operate and maintain electric lines, cable systems and associated equipment used to provide electric service. Often LG&E's electric facilities are located in common easements with other utilities such as gas, telephone, cable TV, etc. The customer shall provide, without cost to LG&E, satisfactory right-of-way and suitable locations and/or housings for any of LG&E's equipment necessary for supplying service.

The customer continues to own and maintain all property within the easement boundaries and the land is available for many uses. However, easements place restrictions on land use. These restrictions help ensure electric lines are protected, accessible, continue to meet code requirements and can be operated and maintained safely. These restrictions, in part, prohibit the placement of any permanent structures within the easement boundaries. Easements also restrict making any large changes in ground profile that could affect clearance to overhead facilities or burial depth to underground facilities. Easements also restrict the use of land for dumping or extensive storage purposes. These restrictions usually exclude small obstructions, such as fencing not exceeding eight feet, dog houses, gardens, etc., provided they do not obstruct access to poles and equipment. Generally, it is permissible to place landscape plantings within easements. However, special restrictions apply to trees planted in easements for overhead lines and for any landscaping placed around ground-mounted electric enclosures. See the section titled "Landscaping and Vegetation Near Electrical Lines."

Easement restrictions specifically prohibit items, such as buildings and building attachments or extensions (decks, awnings, etc.), garages, large sheds, flag poles, fuel tanks, lighting structures,

swimming pools (above or in-ground), radio/TV antennas, piping systems, signs, large playground equipment, etc. Many times, the reason for the easement may not be apparent if electric facilities have been placed underground. Customers should always check property records before placing anything significant on their property. All easement violations will be corrected at the owner's expense. In many cases, easement violations cannot be corrected except by removal of the offending object.

All easements must be obtained before LG&E can begin installing electrical facilities on private property. The easement and service route must also be cleared of construction materials, dumpsters, dirt piles, trees, fences, etc. before LG&E begins any work. LG&E will trim existing trees along its overhead route to provide safe clearances. However, trimming for service lines to the home or building is the responsibility of the customer. The service route is considered to be the area required for LG&E to run lines to the service entrance point for overhead services and to the customer-utility interface point for underground services.

Any work permits and/or easements required to perform work in public way or to install facilities on property other than for the customer being served will be obtained by LG&E.

Electric easement widths vary according to the characteristics of the electric lines and the nature of nearby obstructions. Typically, easements are taken to provide adequate clearances to all existing obstructions and most common types of future obstructions, such as buildings, signs, etc. However, some special installations that may be added after the lines are in place have clearance requirements that may exceed typical easement dimensions. These include special types of obstructions like swimming pools, grain bins, signs, etc. Some additional information on special easement and clearance restrictions can be found below.

SWIMMING POOLS AND OTHER SPECIAL EASEMENT RESTRICTIONS

For obvious safety reasons, LG&E does not allow placing a swimming pool anywhere near overhead or underground lines and/or service drops. Pools must never be placed on any utility easements. The NEC® and NESC® electrical codes both have specific requirements for pools that limit how close a pool may be to any electric facility. See Section 7 for NESC® clearance requirements for pools. LG&E strictly enforces these restrictions.

To be sure there is adequate clearance to meet governing codes, a swimming pool should not be located within twenty-five feet (25') of LG&E's overhead distribution and service conductors,

as measured horizontally from the edge of the pool. Special requirements also apply to pools with diving boards, platforms, slides, etc. Larger distances may be required for clearance to higher voltage lines. Pools should not be installed within five (5) feet measured horizontally, from the edge of the pool or its auxiliary equipment to any underground lines or equipment, including the customer's own underground service line. Customer pool installations must meet the requirements of the latest editions of the NEC® and NESC®.

GENERAL INFORMATION

Electric Service Design Parameters *(continued)*

ADDITIONAL REQUIREMENTS FOR SERVICE LINES

In addition to normal easement restrictions, similar restrictions apply to any overhead secondary service lines serving the customer. Easements are normally not required for these lines because they serve the property owner. Providing and maintaining clear access for the overhead service line is a requirement for

service. While no easement is in place for overhead services, NEC® and NESC® electrical codes prohibit placing many objects under or near overhead service lines. Anything placed under or near the service line, which violates a code or regulation will be corrected or removed at the owner's expense.

If a customer has any questions concerning use of land held in easement, they should contact LG&E Customer Service at 502-589-1444 (Outside Louisville, call 1-800-331-7370)

Requirements for Electric Service Equipment

LG&E frequently has to place poles, guys and ground-mounted electrical equipment on the customer's property to provide service. As a condition for service, the customer is required to provide and maintain an adequate location and space for any necessary electrical service equipment. The customer may also be responsible for providing protection for utility equipment in the form of fencing, barriers, etc. when necessary to prevent damage from vehicle impacts, the operation of other mechanized equipment nearby or any other activities which present a risk of damage to utility equipment.

The space must be sized to provide necessary clearances, oil containment and lighting while conforming to safety codes and LG&E specifications. No customer or third-party items of any kind are to be attached to LG&E facilities or customer facilities under the control of LG&E without prior written permission from the company.

ACCESS AND CLEARANCE TO LG&E SERVICE EQUIPMENT

Access to metering and supply equipment owned or controlled by LG&E must be available during normal working business hours (8:00 a.m. - 5:00 p.m. Monday-Friday) and all other reasonable times as may be required to install, remove, operate and maintain service-related equipment. Access must also be provided at any time for the purpose of dealing with service outages, equipment damage and to correct any type of safety hazard or address any other type of emergency. The customer shall not construct or permit the construction of any structure or device that will restrict LG&E's access to its equipment for any reasonable purposes.

It is LG&E's policy not to take possession of customer keys. If metering or other service supply equipment must be placed in a lockable location, acceptable and agreed upon provisions to access the equipment must be provided. A double-locking system or lockable boxes that allow LG&E access, for example, may be required. Electronic locks present a problem and an agreed-upon access arrangement is required between the utility and the customer. LG&E's Service Representatives will assist with the location and selection of lockable boxes.

Structures and other obstructions near LG&E's electrical equipment can jeopardize the safety of LG&E's employees and

contractors working on and around electrical equipment. Customers should not place any landscaping, fences, sheds or any other structural obstruction near metering equipment or other ground-mounted electrical equipment. Minimum clear space requirements vary by the type of equipment or enclosure involved. LG&E representatives are available to work with customers to avoid any conflicts between LG&E equipment and customer facilities or landscaping.

In general, a minimum of three feet of clearance in front of and two feet to each side of electric meters is required for reading and maintaining electric meters. Larger clear space requirements are necessary in front of other types of metering enclosures with large doors or covers. Adequate clear space on the sides, above and below such enclosures must be provided such that the enclosure covers/doors can be fully opened and/or covers removed so that the internal equipment can be worked on safely. Removable doors, where permitted, must be of a size and weight suitable for handling safely by a single person.

Clear space around other ground-mounted equipment is also required and varies by the type of equipment and the voltage involved. In general, a minimum of 3' from the sides and back of

GENERAL INFORMATION

any padmounted equipment is required. Clear space requirements increase to as much as 10' in front of high voltage padmounted equipment containing a door or cover. Contact your Service Representative for specific clearance information.

LG&E's employees and contractors are authorized to remove any obstruction that interferes with safely working on or

around its electrical equipment. LG&E is not responsible for damage to the customer's landscaping or other structural obstructions that interfere with the ability of its employees or contractors to work safely.

SPECIAL EQUIPMENT REQUIREMENTS

EQUIPMENT VAULTS

Where practical, all LG&E service facilities including transformers and switchgear are to be placed outside of buildings and other structures. LG&E may waive this requirement if the only space available for placing the equipment is inside a building or underground in an enclosure such as a fireproof vault. In these cases, the customer must construct suitable housing for the equipment. The structure must have adequate size, ventilation, oil retaining capacity and lighting to conform to building codes, safety codes and LG&E specifications. It must also meet all applicable fire codes and be approved by the Authorized Inspection Authority.

When vaults are required, customers will secure vault specifications from LG&E and consult LG&E regarding the location and construction of equipment vaults while building plans are being prepared.

Vaults or rooms shall be so located so as to be easily accessible by direct entry from outside the building for the purpose of

installation, maintenance and removal of LG&E equipment. Vaults must be of fireproof construction, be adequately ventilated and drained, and shall comply in all respects with the NEC® and any other applicable codes.

Transformer vaults will contain only transformers, switchgear and other electrical service related equipment. All customer equipment, including secondary fuses, switches, circuit breakers and LG&E's meters will not be installed in transformer rooms and vaults. Customer access to these locations is prohibited unless approved by LG&E. If access is necessary, an LG&E representative is required to be present at any time access is needed. LG&E reserves the right to recover the cost of providing a representative for this purpose.

LG&E reserves the right to serve other customers from its equipment located in vaults on the customer's premises, provided this does not interfere with the customer's service.

SPECIAL REQUIREMENTS FOR OIL-FILLED TRANSFORMERS

Even when padmount transformers and other types of oil-filled equipment are placed outside, special restrictions apply to where they can be located in proximity to buildings. In addition to access considerations, requirements restrict how close oil-filled equipment can be placed to buildings. Details on these requirements can be found on Standards Drawing # 42-06-20 in Drawings section of this handbook.

These guidelines permit oil-filled equipment to be located closer than normal minimum requirements if other steps are taken to reduce the fire potential of the installation. Depending on the type of building involved, clearances may be reduced by using a combination of barrier walls, oil retention pit and/or fire-rated roof over equipment. Please note that the oil retention pit does not qualify as oil containment under environmental regulation purposes. It is strictly to reduce the potential for spreading burning fluids in the event of a catastrophic failure.



METER INFORMATION

CONTAINS FCC ID: R7PEQ1R156

CONTAINS IC: 5264A-ED1R156

Landis
Gyr

GRIDSTREAM RF
90E4D73C



MODULE MODEL:
SE 1049440 FOCUS RFX



ZigBee
Certified product

Va
DEL
DEL
A
000000
000000 kWh
240

Type **FOCUS RXRe-SD**
FORM 2S CL200 240V 3W 60Hz TA=30 Kh 7.2

LG&E 1009596



NXA001009596LTL11

METER INFORMATION

This section contains specific information related to electric metering. Drawings section of this handbook contains the accompanying meter-related drawings. Metering requirements

vary by class of service and the characteristics of the installation. LG&E's service representatives will work with the customer or contractor to determine the necessary requirements.

Requirements for Electric Service Equipment

LG&E-PROVIDED METERING EQUIPMENT

LG&E provides the electric meter(s), instrument-rated transformers and meter-related control wiring required for the purpose of revenue metering for permanent services. The customer is responsible for the installation of all other metering-related equipment including LG&E-provided meter bases, instrument transformers and other enclosure systems required for metering. LG&E will install the electric meter and any related meter wiring once customers have met all of their requirements for electric service.

The contractor is responsible for protecting meter bases, metering transformers and other associated equipment provided by LG&E against loss, damage and theft. It is the customer's responsibility to notify LG&E should service no longer be needed. LG&E will then disconnect service and retrieve the meter and, if applicable, instrument-rated transformers.

METER BASES

LG&E provides meter bases for **single-phase and three-phase temporary and permanent services larger than 400 amps**; these installations require instrument transformers and special bases.

Customers must provide their own single-phase and three-phase, self-contained meter base for services 400 amps and less for both temporary and permanent service. (LG&E will

provide bases for all instrument-rated metering installations.) All customer-provided meter bases must be approved for use by LG&E. Drawings section of this handbook contains an approved listing of bases that are available from local suppliers within LG&E's service territory. LG&E reserves the right to decline service if the customer installs an unapproved meter base.

The customer is responsible for providing an LG&E-approved meter base for single-phase and three-phase temporary and permanent services 400 amps and less. Approved bases for single and three-phase services can be purchased from suppliers in the LG&E service territory.

LG&E does not provide any multiple (ganged) metering assemblies.

CURRENT AND POTENTIAL TRANSFORMERS

LG&E provides any instrument-rated transformers necessary for metering larger single-phase and three-phase services. However, the customer or electrical contractor is responsible for installing the secondary transformers (600 volts or less). Primary instrument transformers (voltages of 600v or greater) will be installed

by the Electric Meter Department. The Electric Meter Department issues the Instrument transformers to the customer or contractor provided the customer has submitted the necessary service load data on the current Electrical Load Data Submittal Sheet.

SPECIAL METERING ENCLOSURES AND EQUIPMENT

In addition to meter bases, larger services may also require additional compartments, enclosures, equipment supports, conduit, etc. to house instrument transformers and other associated metering equipment and wiring. Compartments to be provided by the customer include instrument transformer cabinets, switchgear metering compartments, primary metering compartments and any other special enclosures.

The customer is required to provide and install any special equipment, such as bypass switches, special connectors and surge protection equipment, if required. LG&E will provide and install control wiring for instrument transformers. The customer is to complete all other wiring. The customer must provide and install enclosure systems and equipment to LG&E's specifications. (See Drawings section for detail drawings.)

METER INFORMATION

GANGED METERING

Customers must provide multiple (ganged) metering assemblies, which are typically used for multiple-tenant facilities. Special requirements apply, and customers must work closely with the LG&E Service Locator and the Electric Meter Department to ensure they meet all the requirements for

service. All such equipment must be pre-approved before purchase and installation. LG&E reserves the right to decline service if the customer installs unapproved equipment or enclosures.

OWNERSHIP AND CONTROL OF EQUIPMENT

LG&E retains ownership of the electric meter(s) as well as, if applicable, instrument transformers and associated wiring. Metering installations must not be modified or moved by anyone other than an authorized LG&E representative.

regardless of the reason for replacement. Additionally, the appropriate Authorized Inspection Authority must permit, inspect and approve the electrical work.

Customers own and maintain all meter bases provided by the customer. Customers also own and maintain any other required metering compartments, enclosures and associated equipment. In the event the meter base or other enclosure has to be replaced due to failure, damage or rewiring work, the customer will be responsible for the total cost of replacement, including, in some cases, the cost of a new meter and/or base. A qualified electrical contractor should complete the replacement of the meter base

All meter bases, enclosures and compartments are under the exclusive control of LG&E and will be sealed by LG&E for safety and security. Access to the meter base or any other sealed enclosures without LG&E's authorization is prohibited.

The matrix below is a summary of who provides, installs, owns and controls each component of the metering systems. Maintenance of any component is the responsibility of the component owner.

RESPONSIBILITY MATRIX FOR METERING EQUIPMENT

ITEM	PROVIDE	INSTALL	OWN	CONTROL
Electric Meters (All, Permanent and Temporary)				
Electric Meters	LG&E	LG&E	LG&E	LG&E
208V & 240V Meter Bases (All, Permanent and Temporary)				
Up to 400A—Self-Contained Meter Base	Customer	Customer	Customer	LG&E
Greater Than 400A —Instrument Rated Meter Base	LG&E	Customer	LG&E	LG&E
480V Meter Bases (All, Permanent and Temporary)				
Up to 200A				
Self-Contained Meter Base*—Requires Disconnect	Customer	Customer	Customer	LG&E
Greater Than 200A—Instrument Rated Meter Bases	LG&E	Customer	LG&E	LG&E
Meter Related Equipment				
Meter Base Connectors and Hubs	Customer	Customer	Customer	LG&E
Current/Potential Transformers—Instrument Rated Metering	LG&E	Customer**	LG&E	LG&E
Metering Transformer Wiring —Instrument Rated Metering	LG&E	LG&E	LG&E	LG&E
Meter Compartments—C.T. Cabinet, etc.	Customer	Customer	Customer	LG&E
Metering Compartment Connectors	Customer	Customer	Customer	LG&E
Conduit for Meter Related Wiring, Meter Stands, etc.	Customer	Customer	Customer	LG&E
Meter Supports, Pads, Pedestals, Etc.	Customer	Customer	Customer	LG&E
Meter Bypass Switches—When Required	Customer	Customer	Customer	LG&E
Source Side Load Break Disconnect 480V Metering*	Customer	Customer	Customer	LG&E

* 480V self-contained metering requires a source side non fused load break disconnect installed by the customer in accordance with 2020 NEC 230.82. The switch is provided, owned and installed by the customer but is controlled by the utility so that the meter may be removed safely with the service de-energized. The switch does not meet the requirements for a main service disconnect for the service because it under the control of the utility.

** For primary and transmission voltage LG&E installs

METER INFORMATION

Obtaining Meter Bases And Associated Equipment

LG&E provided meter bases as defined above can be obtained between the hours of 8 a.m. and noon on Mon., Wed. and Fri. from the Electric Meter Department located at:

LG&E's Auburndale Operations Center
Door # 61
6900 Enterprise Drive
Louisville, Kentucky

Approved self-contained meter bases for single and three-phase services 400 amps and less can be purchased from suppliers in the LG&E service territory.

These instructions apply when obtaining metering equipment from LG&E: For single-phase and three-phase meter installations above 400 amps, no base, current transformers or potential

transformers will be issued before an LG&E Service Locator reviews and approves the project's design. LG&E uses load information provided by the customer on the current Electrical Load Data Submittal Sheet to specify electrical metering systems. The Service Locator will provide the Electric Meter Department with a sketch of the designated service location and estimated maximum expected demand (not service entrance size) based on the information provided.



Installation Of Metering Equipment

LOCATION OF METERING

The customer is responsible for providing and maintaining an approved location for the installation of metering equipment, including the metering systems, current transformers, potential transformers, test devices and related enclosures.

All meter bases should be installed outdoors in easily accessible, secure and non-hazardous locations approved by LG&E. The locations must be free from obstructions, corrosive hazards, extreme temperatures and excessive vibration. When it is

impossible or impractical to install the meter base outside, LG&E may approve the installation of the electric meter base in a secure, non-hazardous, accessible indoor location. Approval to install metering equipment indoors must be granted prior to placement of the equipment. It will be the customer's responsibility to relocate any metering equipment not installed in an approved location.

CUSTOMER-FURNISHED EQUIPMENT REQUIREMENTS

All meter bases, metering transformer cabinets and all other enclosures and equipment, including any connector systems the customer provides must be listed for its intended application by a recognized testing organization, such as UL®. Enclosures and compartments intended for outdoor use must meet the minimum requirements of NEMA® 3-R. Such equipment when mounted indoors must meet a minimum of NEMA® 1 requirements. Customer-provided connectors not specified

by LG&E must be clearly marked with the intended conductor size and conductor type (copper and/or aluminum).

All meter bases, metering transformer cabinets and all other enclosures and switchboxes installed for metering must be equipped with provisions to accept an LG&E meter seal. All compartments and enclosures other than the meter base must have provisions for padlocking.

INSTALLATION REQUIREMENTS

No disconnect means will be allowed in front of the electric metering point with the exception of the disconnect required for 480V self-contained metering except by special authorization of LG&E or when required by the NEC® and approved by LG&E. No junction boxes, splice boxes, panels or other compartments, etc. will be allowed ahead of the electric metering point without approval of LG&E unless they are intended for the purpose of housing metering equipment and under the exclusive control of LG&E.

All meter bases, enclosures and compartments must be installed level, plumb and securely fastened to walls or other supports. Customers are responsible for installing equipment in compliance with all relevant LG&E standards and in a manner that protects the metering devices from loss, damage and theft both during construction and while in service.

All meters are to be mounted such that the meter centerline height is 5'-6" above finished grade. If this height cannot be

METER INFORMATION

obtained while meeting other location requirements, the meter can be located between 4'-0" and 6'-0" above finished grade. When special circumstances do not permit this mounting height, LG&E may allow a deviation in the mounting height requirement, but in no case will meters be mounted above 6'-0" above finished grade or less than 3'-0" above finished grade.

The working space directly in front of all metering equipment must be at least 48" wide (2'-0" on either side of the meter) and

6' deep measured from the front of the meter. Contact the Service Locator assigned to your project should the need exist for deviations from these rules.

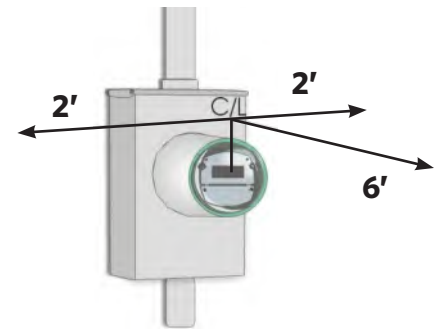

SPECIAL REQUIREMENTS FOR MULTI-METER INSTALLATIONS

All grouped or multiple meter equipment must be approved by LG&E Electric Meter Department prior to installation. Only one customer is to be metered from a given service. Meters at these sites must be a ring-less type with by-pass horns.

When multiple meters are installed at a site, each service to the premise must be uniquely identified with a tag or label in a permanent manner to identify which portion of the premise is served. Placing tags or labels on lids that can be inadvertently interchanged is not acceptable. When the premise is served from a trough system or by multiple individual services, labels should be installed in a visible location on the side of the base.

For ganged meters, labels should be placed on main disconnect if it is immediately adjacent to the meter. If no other form of labeling is possible, one label must be affixed to the lid and another matching label placed inside the meter base in a visible location. See LG&E Standard Drawing # 81 20 03 found in Drawings section.

The customer's name is not acceptable premise identification. The labels must be readily visible and at least one-half inch high. The approved means of permanent markings include engraved nameplates, outdoor rated adhesive type letters, wide-tip permanent markers and paint or paint sticks, Felt-tip pens and label maker tape are not considered permanent marking. The facility owner is responsible for ensuring identification labels remain securely in place and remain readable and unobstructed throughout the life of the equipment. Service will not be established until marking is complete.

METER REMOVAL

LG&E sometimes receives requests to remove self-contained meters so customers can repair or modify internal wiring. Only qualified personnel, authorized by LG&E, are permitted to cut seals and remove meters. LG&E may grant exceptions to qualified electricians for emergency work. Contact the LG&E Meter Department at 502-364-8270. LG&E must be notified as soon as repairs or modifications have been completed.

Extreme caution must be used when meters are removed or installed.

Never remove meters until the source has been disconnected or all loads beyond the meter have been disconnected or otherwise shut off. Manufacturers do not design meters to interrupt load and damage to the metering equipment and/or personal injury could result if the meter is removed under load.

Never remove an instrument-rated meter under any circumstance. Removal of an instrument-rated meter will not provide a break in the incoming service, and extremely high voltages will develop in the meter base and associated instrument transformer wiring if the meter is improperly removed

Removing the meter also does not guarantee the service cannot remain energized by another energy source, such as a standby generator, Uninterruptible Power Supply (UPS) system, etc. Any party that removes a meter, whether authorized or not, accepts all liability for damage or alteration to equipment, injury to persons or property, and loss of revenue from the time the seal is removed until 72 hours after LG&E has been notified that the meter is ready to be resealed.

All meter sockets must be covered and sealed with a transparent cover at any time a meter is not installed for any reason. Unused meter bases must also be sealed with a transparent cover.

METER INFORMATION

INDEX OF METER-RELATED DRAWINGS

The following matrix details the meter applications and the appropriate reference standards. Each of the referenced drawings can be found in Drawings section of this handbook.

REFERENCE DRAWINGS FOR RESIDENTIAL AND COMMERCIAL METERING REQUIREMENTS

SERVICE VOLTAGE	SERVICE AMPACITY	APPLICABLE STANDARD DRAWING	
120/240V And 240/480V 1Ø 3-Wire OR 120/208 (Network) 3-Wire	0 to 200 Amps	1 Conductors Max./Ø	81-20-10*
	>200 to 400 Amps	2 Conductors Max./Ø	81-10-41* and 81-20-02
	>400 to 1200 Amps	2 Conductors Max./Ø	81-10-02*
240V 3Ø 3-Wire Corner Grounded Delta	0 to 200 Amps	1 Conductors Max./Ø	81-20-10*
	200 to 800 Amps	1-2 Conductors Max./Ø	81-10-03
	800 to 2000 Amps	5 Conductors Max./Ø	81-10-10
	Over 2000 Amps	Switchgear	81-10-30*
Switchgear		81-10-30	
480V 3Ø 3-Wire Ungrounded Delta	0 to 200 Amps	1 Conductors Max./Ø	81-20-11
	200 to 800 Amps	1-2 Conductors Max./Ø	81-10-05
	800 to 2000 Amps	5 Conductors Max./Ø	81-10-11
		Switchgear	81-10-30
	Over 2000 Amps	Switchgear	81-10-30
120/208V 3Ø 4-Wire Grounded WYE OR 277/480V 3Ø 4-Wire Grounded WYE	0 to 400 Amps	2 Conductors Max./Ø	81-20-10
	400 to 800 Amps	2 Conductors Max./Ø	81-10-07
	800 to 2000 Amps	5 Conductors Max./Ø	81-10-12
		Switchgear	81-10-32
	Over 2000 Amps	Switchgear	81-10-32

* Refer to Standard Drawing 81-10-40 for additional requirements on self-contained meter bases.

METER INFORMATION

The following table also details other meter installation drawings of interest.

ADDITIONAL DRAWINGS FOR 1-PHASE RESIDENTIAL AND COMMERCIAL SERVICE INSTALLATIONS

SERVICE VOLTAGE	SERVICE AMPACITY	APPLICABLE STANDARD DRAWING		
		Meter Socket	Overhead	Underground
			All	All
120/240 Volt 1-Phase 3 Wire	0 to 200 Amps	81-20-10*	81-20-02	52-01-06 and 81-20-06
	Over 200 Amps to 400 Amps	81-10-41*		52-01-06
	Over 400 Amps to 1200 Amps	81-10-02* and 81-20-10**		

* Refer to Standard Drawing 81-10-40 A for additional requirements on self-contained meter bases.

** Single-phase transformer-rated bases require fifth and sixth jaws located in the nine and three o'clock positions.



METER INFORMATION

Service Type—Single-Phase 120/240 Volt, 2 / 3 wire	MANUFACTURERS	CATALOG NUMBERS
125 Amp Overhead/Underground	Milbank	U7487-XL-TG-K
	Durham	UHT-RS101B
	Siemens	UAT111-0PZ
	Siemens	UAT111-0PQG
	Eaton	UHTRS101BCH
225 Amp Overhead/Underground	Brooks	601U43W1B41-B20A00
	Milbank	U7040-XL-TG-KK
	Durham	UHT-RS212B
	Siemens	UAT417-0P
	Siemens	UAT417-XPQG
Lever Bypass	Eaton	UTE4213TCH
	Eaton	UHTRS213BE
320 Amp - Overhead	Milbank	U1079-R, U2448-X
	Durham	UT-H4300T
	Siemens	47704-01
	Siemens	47604-02
	Siemens	47704-01NU
	Eaton	UTH4336TCH
320 Amp - Underground	Milbank	U1129-O-K3L-K2L, U1797-O-K3L-K2L, U2448-X
	Durham	UT-H4330U
	Siemens	44704-01
	Siemens	48704-82GP
	With 200 Amp Main(s)	Siemens
	Eaton	UTH4336TCH

Catalog numbers do not reflect Hub Size or Cover Plates.

Catalog numbers for 320 Amp bases do not include wire termination lugs.

Bases must be UL-listed, have bypass capability and be of the ringless design.

Please call for requirements on any services not listed above:

Louisville Gas and Electric Company

Electric Meter Department

(502) 364-8270

METER INFORMATION

Service Type—Three Phase	Manufacturers	Catalog Numbers
125 Amp—Overhead / Underground None Approved—Use 225 Amp		
225 Amp Overhead/Underground		
5 Terminal	Eaton	UTH5213BNDCH
7 Terminal	Eaton	UTH7213UCH
* 7 Terminal (LG&E-Furnished)	Talon	40407-0250
* 5 Terminal (LG&E-Furnished)	Talon	9804-8592
5 Terminal	Milbank	U9581
7 Terminal	Milbank	U9701-RRL
320 Amp Overhead/Underground		
5 Terminal (240V Delta & 3Ph Network Only)	Eaton	UTH5330UCH
7 Terminal (120/208 Wye Only)	Eaton	UTH7330UCH
5 Terminal (240V Delta & 3Ph Network Only)	Siemens	47705-02
7 Terminal (120/208 Wye Only)	Siemens	48707-02
5 Terminal (240V Delta & 3Ph Network Only)	Milbank	U4419
7 Terminal (120/208 Wye Only)	Milbank	U2120X or U2594X

Catalog numbers do not reflect Hub Size or Cover Plates.
 Catalog numbers for 320 Amp bases do not include wire termination lugs.
 Bases must be UL-listed, have lever bypass capability and be of the ringless design.
 5 Terminal Bases for: 240V 3W Delta, 480V 3W Delta, and 208V 3W Wye Network
 7 Terminal Bases for : 120/208V 4W Wye and 277/480V 4W Wye

Please call for requirements on any services not listed in these charts.
 Louisville Gas and Electric Company
 Electric Meter Department
 (502) 364-8270

Service Type—Single and Polyphase Multi-Centers	Manufacturers	Catalog Numbers
125 Amp—Overhead / Underground		
2 Gang	Eaton	UHT2R112BCH
Single-phase	Siemens	WMM32125RJB, WMM42125RJB, WMM52125RJB, WML13100RJ, WML23100RJ, WML33100RJ
Polyphase - 7T	Siemens	WML43100RJ
225 Amp Overhead/Underground		
2 Gang—Single-phase	Eaton	UHT2R2332TCH
	ABB	TMPR312422R
Polyphase - 7T	Milbank	U1252-RRL-KK-K1
2 Gang—Single-phase	Siemens	WMM32225RJB, WMM42225RJB, WML13225RJ, WML23225RJ
Single-phase Polyphase - 7T	Siemens	WML33225RJ, WML43225RJ
320 Amp Overhead/Underground		
Non-Approved		

Centers must be UL-listed, have bypass capability and be of the ringless design.

TEMPORARY & PERMANENT SERVICES



TEMPORARY & PERMANENT SERVICES

Temporary Services 600 Volts or Less

Temporary electric service is defined as a means of supplying electric service to a site for **less than one year**. The most common use for a temporary service is to provide power to a construction site until provisions can be made for permanent service. **The customer is responsible for all costs to provide temporary service**, including the installation and removal of all equipment provided exclusively for the purpose of providing temporary service. LG&E's service representatives will work with customers to identify all associated costs. In some cases, a customer or contractor may be able to provide an alternate source of temporary power, such as a portable generator, more cost effectively than having LG&E provide a temporary service.

To begin the process, the customer must follow the same procedures to apply for temporary service as they would for permanent service. The first step toward arranging for service is to follow the guidelines in the section entitled "Applying for Electric Service." The customer must contact LG&E and complete an application for electric service. The form can be completed online, lge-ku.com, at LG&E's walk-in customer service center (9th and Broadway) or by phone when you call **502-589-1444 (Outside Louisville, call 1-800-331-7370)**. All other steps in the section "Steps for Obtaining Electric Service" must also be followed. A separate application of service is required for temporary service, although applications for temporary and permanent service can be

processed at the same time. An electrical inspection at the construction site by the Authorized Inspection Authority is required prior to notifying LG&E to install the meter and activate the service. LG&E must also approve the installation prior to connecting the temporary service to ensure the safety of LG&E employees who are working to complete your service request.

The requirements in this section cover only routine installations. Special requirements may apply for unusual or non-standard applications. For example, special requirements may apply where the distance from LG&E's service facilities is great or ground clearance or other circumstances necessitate special requirements.

The customer is responsible for protecting meters and metering transformers and other associated equipment provided by LG&E against loss, damage and theft. The customer should notify LG&E as soon as the service is no longer needed. LG&E will then close the customer's account, disconnect and remove the temporary service and any unneeded service equipment and retrieve the electric meter and associated equipment.



AVAILABLE SERVICE

Details in this section cover single-phase and three-phase provisions for temporary secondary services, typically 480 volts and below. Higher voltage temporary service may be provided if requested; however, each installation will require a special design and equipment. The most common temporary service

is a 120/240 volt, 1-phase, 3-wire service. All single-phase services must be wired for three-wire service regardless of need. Two-wire service is no longer provided. The chart below shows available electric service ratings for single-phase 120/240 volt temporary services.

AVAILABLE SINGLE-PHASE TEMPORARY SERVICES

SERVICE VOLTAGE	SERVICE AMPACITY	APPLICABLE STANDARD DRAWING	
120/240V 1-Phase, 3-Wire (only) Overhead or Underground	0 to 200 Amps	1 Conductor Max. Per Ø	81-20-10
	200 to 400 Amps	2 Conductors Max. Per Ø	81-10-41
	400 to 800 Amps	2 Conductors Max. Per Ø	81-10-02

Transformer-rated metering will be necessary for services larger than 400 amps and additional requirements apply. Contact your Service Locator for information on the additional requirements or when temporary service is requested at voltages other than 120/240 volt 1-phase, 3-wire.

TEMPORARY & PERMANENT SERVICES

Temporary Overhead Services

CLEARANCE REQUIREMENTS

The National Electrical Safety Code (NESC®) and the National Electrical Code (NEC®) have established minimum overhead clearance requirements to ensure safe heights for different types of electrical conductors over various terrains depending upon the type of usage expected. The diagram illustrates ground clearance requirements for a typical overhead temporary electric service. For additional information, refer to the latest NESC® and/or NEC® codes. Your electrical inspector and LG&E's Service Representative will be able to assist you to design a temporary service support so adequate clearance is provided. Although LG&E provides the overhead service conductors, the customer must provide adequate clearance at the temporary structure to ensure all applicable clearance requirements can be met.

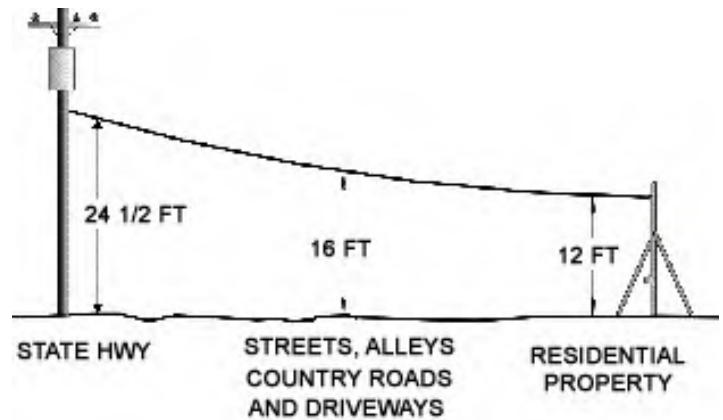

RESPONSIBILITIES

Customer-Owned and Installed Equipment

(All Equipment Installed To LG&E Specifications)

- Post, Bracing And Cable Attachment Provisions
- Meter Base And Service Disconnect
- Service Entrance Conductors (Weatherhead And Beyond)
- Ground Conductors, Rods, Etc.

Notes

- Timber sizes for service supports found in the standard drawing # 12 10 02 in Drawings section of this handbook are recommended as the minimum for the strength required. LG&E assumes no responsibility for failure of support caused by the attachment of its service.
- 2020 NEC® Article 590.6 requires approved ground-fault circuit protectors on all 15, 20 and 30 amp single-phase receptacle outlets.
- Service neutral and meter base must be permanently grounded in accordance with NEC® guidelines.

LG&E-Owned and Installed Equipment

- Utility Service Lines (To Weatherhead On Customer's Structure)
- Connection To Customer Wiring
- Electric Meter And Metering Transformers, If Applicable

Note: Instrument transformers, if required, will be provided by LG&E, but installed by the customer. LG&E will provide and install any associated meter wiring.

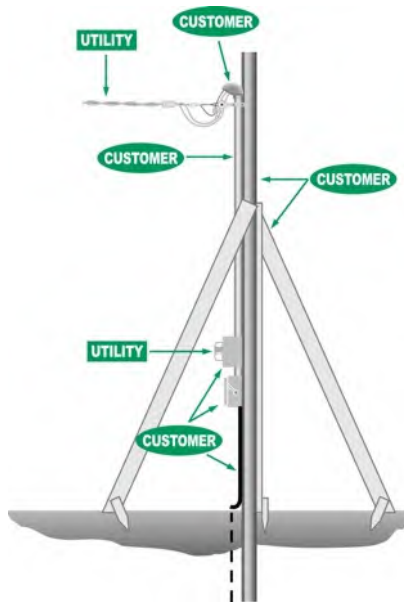

OVERHEAD TEMPORARY SERVICE LOCATION

For services up to 200 amps, a temporary meter/termination post should be located on the Customer's property and **within 75 feet** of the utility pole for services that will serve the site. Contact an LG&E Service Locator before construction begins (502-589-1444) if it is not obvious which utility pole will be used to provide service to the site or if the service distance will exceed 75 feet. Additional costs may be involved for distances exceeding 75 feet. Larger single-phase and three-phase temporary services are available, if necessary, but special requirements will apply. Contact the Service Locator for additional information.

CONSTRUCTION STANDARDS

All overhead temporary services are to be constructed in accordance with LG&E Standard Drawings # 12 10 02 found in Drawings section of this handbook. Another drawing that may be useful in the construction of underground temporary services is the meter base detail # 81 20 10 shown in Drawings section of this handbook.

TEMPORARY & PERMANENT SERVICES

Temporary Underground Services

BURIAL REQUIREMENTS

The National Electrical Safety Code (NESC®) and the National Electrical Code (NEC®) have established minimum burial depths for the safe installation of underground electrical conductors for all wiring methods and all types of terrain. The customer's service must be brought to within 18" of a splice box or transformer, as required. Sufficient slack, as shown on the standards **# 52 10 02**, must be left such that LG&E can connect the service. LG&E will make the connection to the customer's cable and activate service once all of the requirements for service have been met and LG&E is notified that the customer is ready for service.

The customer must ensure the burial depth meets code requirements at all times and is sufficient to protect the service conductor from damage imposed by expected surface usage and/or changes in grade. For additional information on burial requirements, refer to the latest edition of the NESC®, NEC® or contact the Authorized Inspection Authority.



RESPONSIBILITIES

Customer-Owned and Installed Equipment

(All equipment installed to LG&E specifications)

- Service support (post or pedestal) and bracing
- Meter base and disconnect
- Service entrance conductors
- Service line and conduit to the transformer or splice box
- Ground conductors, rods, etc.

Notes

- 2017 NEC® Article 590.6 requires approved ground-fault circuit protectors on all 15 and 20 amp single-phase receptacle outlets
- Service neutral and meter base must be permanently grounded in accordance with NEC® guidelines.

LG&E-Owned and Installed Equipment

- Transformer or splice box
- Utility secondary lines to customer's point of ownership (for service from pedestal)
- Connection to customer wiring
- Electric meter and metering transformers, if required

Note: Instrument transformers, if required, will be provided by the LG&E, but installed by the customer. LG&E will provide and install any associated meter wiring.

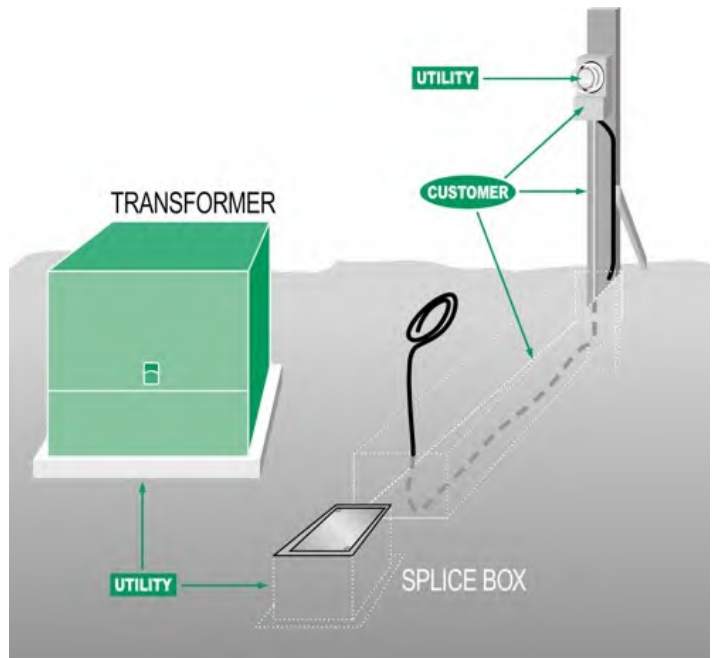

CONSTRUCTION STANDARDS

All underground temporary services are to be constructed in accordance with LG&E Standard Drawings **# 52 10 02** found in Drawings section of this handbook.

TEMPORARY & PERMANENT SERVICES

Temporary Underground Services *(continued)*

UNDERGROUND TEMPORARY SERVICE LOCATION

All residential lots with underground electric facilities will have either a transformer or a service splice box located adjacent to one of the property lines. In rare cases, a lot may have both a transformer and a splice box located along property lines. The Temporary Service structure should be located in the following manner:

1. Whenever a transformer is located along either property line, locate the temporary structure on the side of the lot closest to the transformer and run the service conductors to within 18" of the secondary side of the transformer. (See note 1.)
2. If both a transformer and splice box are present, locate the temporary structure on the side of the lot closest to transformer and run the service conductors to within 18" of the secondary side of the transformer. (See note 1.)
3. If only a splice box is present, locate the temporary structure on the side of the lot closest to the splice box and run the service conductors to within 18" of the splice box.

Note 1: The secondary side of the transformer is located on the right-hand side when facing the front of the transformer.

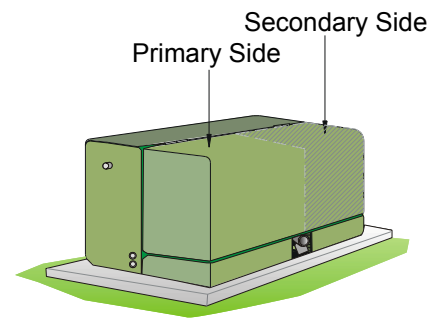

If there is neither a transformer nor a splice box, call the appropriate service locator. All structures used for temporary service should be located outside of the equipment clear working zone as shown in the detail below. Contractors should use care not to route temporary service conductors across or along the path intended for the permanent service conductors.

Temporary electric services for underground installations are to be constructed in accordance with LG&E Standard Drawing # 52 10 02 shown in Drawings section of this handbook. Another drawing that may be useful in the construction of underground temporary services is the meter base detail # 81-20-10 shown in Drawings section of this handbook. Note: Instrument transformers, if required, will be provided by LG&E, but installed by the customer. LG&E will provide and install any associated contact meter wiring.

Please be aware of LG&E's requirements for a clear work zone area around utility equipment for temporary service structures. Temporary service structures should be located out of the reserved work zone area.

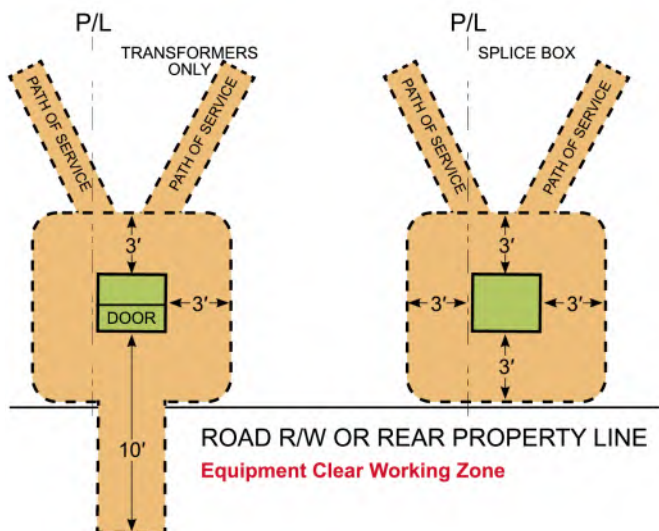

Please be aware of LG&E's requirements for a clear work zone area around utility equipment. Service structures should be located out of the reserved work zone area.

TEMPORARY & PERMANENT SERVICES

General Information for Permanent Residential Service

This section applies to permanent residential service for most Single-Family Residences, Multi-Family Structures and Mobile Homes.

To begin the process for permanent service, the customer must follow the procedures in the section entitled "Applying for Electric Service." The customer must contact LG&E and complete an application for electric service. The form can be completed online, lge-ku.com, at LG&E's walk-in customer service center (9th and Broadway) or by phone when you call **502-589-1444 (Outside Louisville at 1-800-331-7370)**. A separate application is required if temporary service is needed prior to the installation of the permanent service, although applications for temporary and permanent service can be processed at the same time. (For information on temporary service, see the section titled "Temporary Services 600 Volts Or Less".) The customer must also follow all other steps in the section "Steps for Obtaining Electric Service."

Because the design of a permanent service is far more involved than temporary service, customers should review the sections titled "General Information" and "Meter Information" and the section that deals with the type of facility being served prior to finalizing the design of the electric service.

The requirements in the following sections cover only routine installations. Special requirements may apply for unusual or non-standard applications. For example, special requirements may apply for larger home services or services where the distance from LG&E's serving facilities are great or ground clearance or other circumstances necessitate special requirements. Special designs will be required for all Multi-Family installations.

PERMITTING AND INSPECTION

In all cases, an electrical inspection by the Authorized Inspection Authority is required prior to notifying LG&E to install the meter and activate the service. LG&E must also approve the installation prior to connecting service to ensure the safety of LG&E employees who are working to complete your service request.

SERVICE ENTRANCE LOCATION

LG&E's Service Locator will designate the service entrance and meter location and work with customers to finalize all necessary service parameters. Unless expressly authorized by LG&E, no electrical work should start until LG&E has determined all of the service requirements. LG&E is not responsible for any delays, reconstruction work or additional cost incurred by customers or their contractors/builders if work is started before all of the necessary service parameters have been finalized.

The only exception to the above requirements are for underground services for single-family homes less than 300 amps in dedicated underground subdivisions where underground facilities have been pre-installed by LG&E. In these installations, it is practical for the customer or contractor to identify all of the service parameters, including the service entrance/meter location from information below and as provided on Standard **# 52 01 06** in Drawings section of this handbook. It is the customer's responsibility to contact the LG&E Service Locator for unusual construction requirements and/or when there is any confusion as to where the service entrance equipment should be located or where the customer's underground service conductors should terminate.

GROUNDING

The NEC® requires one or more ground rods at the service entrance. Some Authorized Inspection Authorities require a minimum of two, so customers should consult with the Inspection Authority before construction begins. Ground rods need to meet the minimum requirements of the NEC® and should be eight feet or longer. If multiple rods are installed,

rods should be installed at least six feet apart. The grounding electrode shall be continuous from the service entrance main disconnect to one or both of the driven ground rod(s). All of the grounding bonds shall meet or exceed NEC® requirements.

MOTOR RESTRICTIONS

The most common types of motors found in a residence are those involved with HVAC systems. However, the following requirements apply to any type of motor. Single-phase motors may be served at 120 volts if the locked rotor current at **rated voltage or any other load requiring large starting currents in excess of 50 amperes**. The use of the motor does not otherwise interfere with service to others. Motors with locked rotor current ratings in excess of a maximum of 50 amperes must be served at 240 volts.

Single-phase motors and residential cooling installations served at 240 volts are limited to a maximum of **125 lock-rotor-amps (LRA), including all associated equipment configured for simultaneous starting** unless LG&E grants a specific exception in advance. Again, this rule applies to the sum of all starting currents for multiple devices arranged for simultaneous starting. The LG&E tariff contains more information on motor starting limitations.

TEMPORARY & PERMANENT SERVICES

General Information for Permanent Residential Service *(continued)*

AVAILABLE SERVICE

Two types of residential electrical service are available, **Overhead and Underground.** **Underground** service is generally available to everyone. Specific exceptions include areas subject to high water or flooding and in areas where excavation may be limited due to soil/rock conditions. If the new home is in an established underground residential subdivision, service must be provided underground. **Overhead** service is available if nearby utility facilities are overhead, except in areas specifically prohibited by local ordinance. The customer is responsible for any additional costs associated with underground service when overhead facilities are available even when ordinance or other restrictions limit providing service overhead. It is the customer's responsibility to be aware of any applicable local codes and ordinances. Code requirements specify a minimum 100 amp service entrance for permanent residential services. All services must be wired for three-wire service. Two-wire service is no longer provided.

The only service voltage available for permanent Single-Family and Mobile Home residential applications is 120/240 volt single-phase, three-wire service up to 800 amps unless otherwise approved by LG&E. All single-phase services must be wired for three-wire service regardless of need. Two-wire service is no longer provided. For the largest homes that require services larger than 800 amps, the only option will usually be to provide 120/208 three-phase, four-wire service. Three-phase service cannot be established on the Residential Rate plan for Single-Family homes and must be served under the General Service rate. Customers should be aware that the cost to extend three-phase service to serve residential loads can be costly unless three-phase lines are nearby. Most Multi-Family facilities will also be served by 120/240 volt single-phase, three-wire service up to 800 amps except for high rise Multi-Family Developments. These installations will generally be served with three-phase service.

This chart shows available electric service ratings for single-family residential structures and for satellite buildings. The size of service depends on the power requirements of the home and any associated equipment or facilities. LG&E does not determine the customer's power requirements.

ELECTRIC SERVICE RATINGS FOR PERMANENT SINGLE-PHASE 120/240 VOLT SERVICES

SERVICE VOLTAGE	SERVICE AMPACITY	APPLICABLE STANDARD DRAWING	
120/240V 1-Phase Overhead or Underground	0 to 200 Amps	1 Conductor Max. Per Ø	81 20 0
	>200 to 400 Amps	2 Conductors Max. Per Ø	81 10 41
	>400 to 800 Amps unless otherwise approved by LG&E	2 Conductors Max. Per Ø	81 10 02
	>800 to 1200 Amps	5 Conductors Max. Per Ø	81 10 02

Transformer-rated metering will be necessary for single-phase services larger than 400 amps and additional requirements apply. Contact your Service Locator for information on the additional requirements.

TEMPORARY & PERMANENT SERVICES

Permanent Single-Family Residential Service

LINE EXTENSIONS

In accordance with KPSC 807 KAR 5041 Section 12, LG&E will extend single-phase overhead lines up to 1,000 feet to provide permanent, full-time service to a single-family residence and provide service equipment and an overhead serve at no cost to the customer. Customers are responsible for the full cost of overhead line extension above 1,000 feet. Customers are responsible for the full incremental cost to provide service underground, regardless of

how far lines must be extended to serve and must provide the underground service conductors to the home. Customers in established underground residential developments will not nominally incur any additional cost unless the development consists of large lots which require high voltage lines to be extended onto the property in order to provide an adequate level of service.

PERMANENT OVERHEAD RESIDENTIAL ELECTRIC SERVICES

CLEARANCE REQUIREMENTS

The National Electrical Safety Code (NESC®) and the National Electrical Code (NEC®) have established minimum overhead clearance requirements to ensure safe heights for different types of electrical conductors over various terrains depending on the type of usage expected. The diagram illustrates ground clearance requirements for a typical overhead permanent electric service. For additional information, refer to the latest NESC® and/or NEC® codes. Your electrical inspector and LG&E's Service Representative will be able to assist you with a permanent service so adequate clearance is provided. Although LG&E provides the overhead service conductors, the customer must provide

adequate clearance at the facility to ensure all applicable clearance requirements can be met.

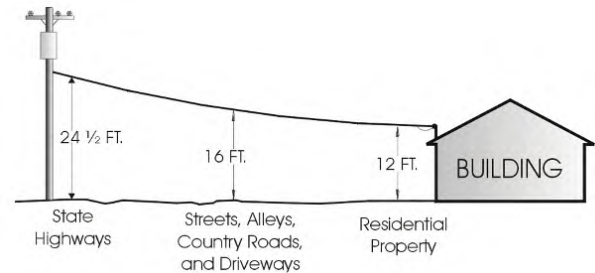

RESPONSIBILITY

The figure below identifies Utility and Customer responsibilities for a typical overhead electrical service so adequate clearance is provided. Although LG&E provides the overhead service conductors, the customer must provide adequate clearance at the facility to ensure all applicable clearance requirements can be met.

Customer-owned and installed equipment

(All equipment installed to lg&e specifications)

- Weatherhead and mast /service attachment point
- Meter base, metering enclosures and disconnect
- Service entrance conductors
- Ground conductors, rods, etc.

LG&E-owned and installed equipment

- Utility service lines
- Connection to customer wiring
- Meter and metering transformer, if required

Notes: Instrument transformers, if required, will be provided by LG&E, but installed by the customer. LG&E will provide and install any associated meter wiring.

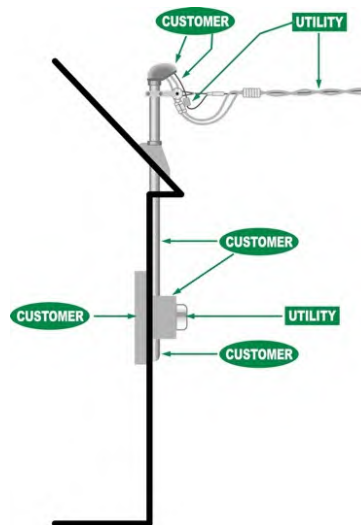

CONSTRUCTION STANDARDS

All residential overhead services are to be constructed in accordance with LG&E Standard Drawings # 8120 02 found in Drawings section of this handbook. Note: Instrument transformers, if required, will be provided by LG&E, but installed by customer. LG&E will provide and install any associated contact meter wiring.

TEMPORARY & PERMANENT SERVICES

Permanent Underground Residential Electric Services

BURIAL REQUIREMENTS

The National Electrical Safety Code (NESC®) and the National Electrical Code (NEC®) have established minimum burial depths for the safe installation of underground electrical conductors. The customer's service must be brought to within 18" of a splice box or transformer, as required. Sufficient slack, as shown on the standards # 51 04 03, must be left such that LG&E can connect the service. LG&E will make the connection to the customer's cable and activate service once all of the requirements for service have been met and LG&E is notified that the customer is ready for service.

The customer at all times must ensure the burial depth meets code requirements and is sufficient to protect the service conductor from damage imposed by expected surface usage and/or changes in grade. For additional information on burial requirements, refer to the latest edition of the NESC®, NEC® or contact the Authorized Inspection Authority.



RESPONSIBILITY

The illustration below shows a typical underground electrical service and identifies the shared responsibilities between LG&E and the Customer. LG&E strongly encourages customers to install all underground service conductors in approved conduit to avoid damage, to extend life of the cable system and to facilitate replacement when necessary.

Customer-owned and installed equipment

(All equipment installed to LG&E specifications)

- Splice box (overhead to underground service only)
- Meter base, meter enclosures and disconnect
- Service lines and conduit to the transformer or Splice box
- Ground conductors, rods, etc.

LG&E-owned and installed equipment

- Transformer and/or splice box
- Utility secondary lines to the customer's point of ownership
- Meter and metering transformers, if applicable

Notes: Instrument transformers, if required, will be provided by LG&E, but installed by the customer. LG&E will provide and install any associated meter wiring.

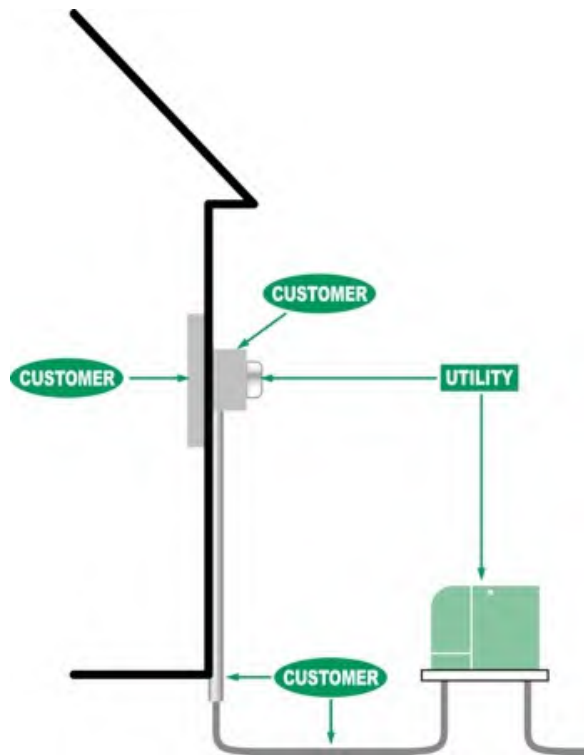

CONSTRUCTION STANDARDS

All permanent residential underground services in subdivisions fed by underground service are to be installed in accordance with LG&E Standard Drawing # 52 01 06 found in Drawings section of this handbook.

When an underground service is requested in an area where electric facilities are overhead, the customer will usually be

required to install a splice box for LG&E's use in accordance with the requirements of LG&E Standard Drawing # 51 04 03 found in Drawings section of this handbook. LG&E will take ownership of the splice box once the installation has been approved for use and service has been connected.

TEMPORARY & PERMANENT SERVICES

Permanent Underground Residential Electric Services *(continued)*

SERVICE ENTRANCE LOCATION

Customers will normally require LG&E to designate the location of the service entrance on the home. However, customers planning underground services not exceeding 300 amps in dedicated underground subdivisions where underground facilities have been pre-installed by LG&E can determine their own service entrance and meter location based on the information below and as shown on Standard #520106 in Drawings section of this handbook. It is the customer's responsibility to contact the LG&E Service Locator for unusual construction requirements and/or when there is any confusion as to where the service entrance equipment should be located or where the customer's underground service conductors should terminate.

All residential lots with underground electric facilities will have either a transformer or a service splice box located adjacent to one of the property lines. In rare cases, a lot may have both a transformer and a splice box located along property lines. The service entrance should be located on the front corner of the house closest to the location where the service will originate. The service origination point can be determined in the following manner:

1. Whenever a transformer is located along either property line, locate the entrance point on the side of the home closest to the transformer and run the service conductors to within 18" of the secondary side of the transformer. (See note 1.)
2. If both a transformer and splice box are present, locate the entrance point on the side of the home closest to transformer and run the service conductors to within 18" of the secondary side of the transformer. (See note 1.)
3. If only a splice box is present, locate the entrance point on the side of the home closest to the splice box and run the service conductors to within 18" of the splice box.

Note 1: The secondary side of the transformer is located on the right-hand side when facing the front of the transformer

If there is neither a transformer nor a splice box, call the appropriate Service Locator.

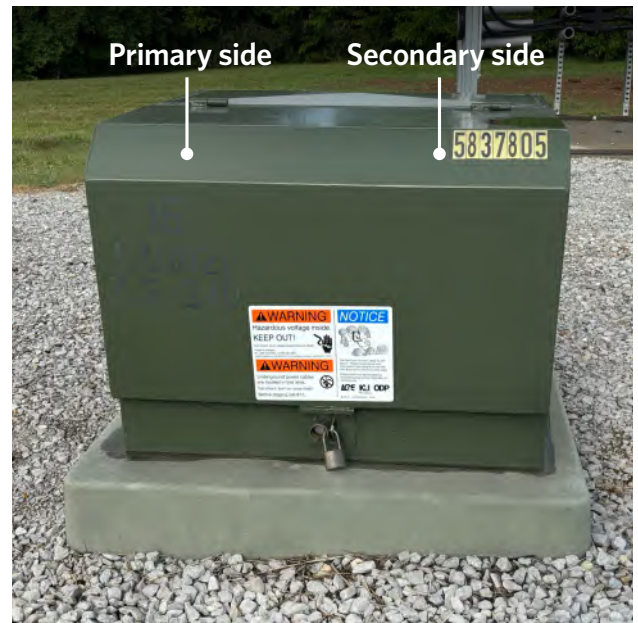

TEMPORARY & PERMANENT SERVICES

Mobile Home Services

DEFINITION

NEC® Article 550) A mobile home is a factory-assembled structure(s) transportable in one or more sections that is built on a permanent chassis and is designed to be used as a dwelling without a permanent foundation where connected to the required utilities and that includes the plumbing, heating, air conditioning and electrical system contained therein.

The information below applies to all mobile home services, even if the structure is subsequently placed on a permanent or semi-permanent foundation. Service to structures classified as Manufactured (or Modular) Housing, as defined in NEC® Article 550, which are mounted on a permanent foundation, (i.e. not classified as a mobile home) can be constructed to the requirements for Permanent Residential Service, provided all of the requirements of NEC® Article 550 are met and the installation is approved by the Authorized Inspection Authority. See the requirements in "Permanent Residential Service". In lieu of meeting the requirements for permanent residential service, service to manufactured housing will be treated in the same manner as a mobile home service

Mobile home parks may be served either by the placement of individual services from LG&E or by metering at a single site for the entire park or subgroups within the park by the owner. The instructions below are intended only for standard, permanently wired LG&E-provided service to mobile homes. Consult the Authorized Inspection Authority for special requirements for cord type service connections or any other special requirements.



The first step to arrange service for a mobile home is to make an application for service. See the section "Arranging for Service". The customer must contact LG&E and complete an application for electric service. The form can be completed online lge-ku.com, at LG&E's walk-in customer service center (9th and Broadway) or by phone when you **call 502-589-1444 (Outside Louisville at 1-800-331-7370)**. All other steps in the section "Arranging for Electric Service" must also be followed. LG&E recommends the use of a licensed electrical contractor to permanently connect service to any mobile home. In some jurisdictions in LG&E's service territory, the Authorized Inspection Authority requires the use of a licensed contractor if the mobile home customer is not the property owner. Regardless of who performs the work, an electrical permit must be obtained from the Authorized Inspection Authority. Once all work has been completed and the service has passed inspection by the Authorized Inspection Authority, LG&E will energize the service following notification that the service is ready and provided all other requirements for service have been met.

LINE EXTENSIONS

In accordance with 807 KAR 5041 Section 12, LG&E will extend a single-phase overhead electric line up to 1000 feet at no cost to the customer provided the mobile home is placed on a permanent foundation. The customer will be charged for the full cost of any extension beyond 1000 feet. If the mobile home is not placed on a permanent foundation, then lines will be extended only 150 feet

without charge. A fixed customer advance charge will be involved for all extensions between 151 feet and 300 feet. The full cost of extensions beyond 300 feet will be paid by the customer, except that all customer advance fees between 151 feet and 1000 feet will be subject to refund provided continuous service is provided to the site for a minimum period of four years.

SERVICE EQUIPMENT

Mobile Home service equipment will be provided to the requirements of the NEC® and approved for use by the Authorized Inspection Authority. The following requirements apply:

TYPE OF SERVICE

Two types of residential electrical service are available, Overhead and Underground. Underground service is generally available to everyone. Specific exceptions include areas subject

to high water or flooding and in areas where excavation may be limited due to soil/rock conditions. Overhead service is available if nearby LG&E facilities are overhead, except in areas specifically prohibited by local ordinance. The customer is responsible for any additional costs associated with underground service when overhead facilities are available even when ordinance or other restrictions limit providing service overhead. It is the customer's responsibility to be aware of any applicable local codes and ordinances.

TEMPORARY & PERMANENT SERVICES

Mobile Home Services *(continued)*

GENERAL REQUIREMENTS

Service equipment for mobile homes shall be located adjacent to the mobile home and not mounted in or on the mobile home. This equipment shall be accessible and shall be located in sight from and not more than 30 feet from the exterior wall of the mobile home it serves.

LG&E will provide all utility facilities up to the Point Of Delivery. The Point Of Delivery for overhead services is defined as the customer-owned (LG&E approved) terminating structure and service entrance. For underground services, the Point Of Delivery is defined as either a padmounted transformer or service enclosure as required. All other material is to be

furnished and installed by the customer except for the LG&E-owned electric meter. The customer's facilities must be installed in accordance with all national, state, local, utility codes, standards and/or regulations.

SERVICE DISCONNECT

The customer must provide a weatherproof disconnect switch, over-current protection, grounding provisions and all other associated facilities necessary to provide service to the requirements of the NEC®. The disconnect must be located on the load side of the meter.

OVERHEAD SERVICES

The customer must provide a suitable pole or structure of adequate size and strength for terminating the overhead electric service drop provided by LG&E. The customer must also provide the service weatherhead and all other associated service entrance equipment. Customer-provided poles must have sufficient height to provide all required clearance for LG&E's service drop and any telephone, cable TV or other attachments. Poles must not be less than five inches in diameter at the top if round and shall be set at depths appropriate for the pole's length. Guying is required unless otherwise specified by LG&E. Guy and guy attachments to be provided by customer. Guying to provide adequate lateral support.

Wooden poles must be pressure or thermally treated with an LG&E-approved preservative. Metering and service equipment can be located on the customer's termination structure. All termination structures must be approved for use by LG&E.

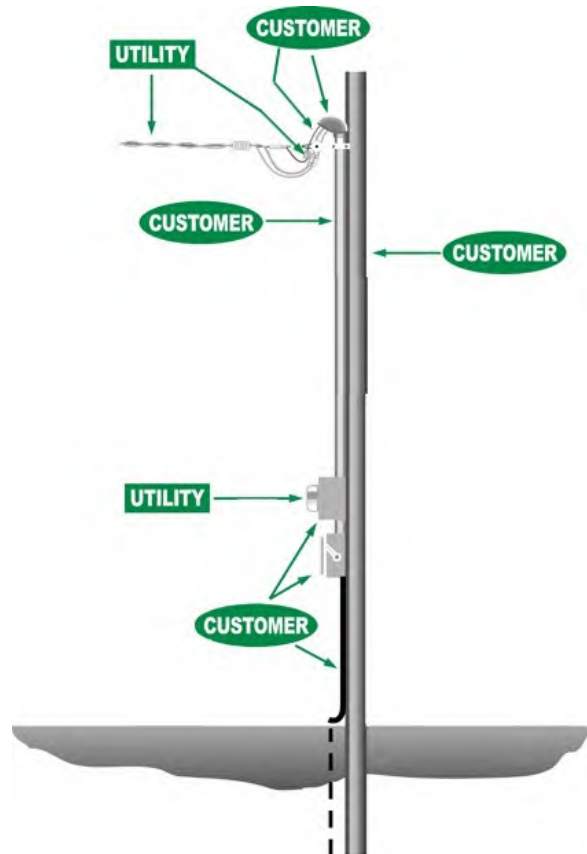
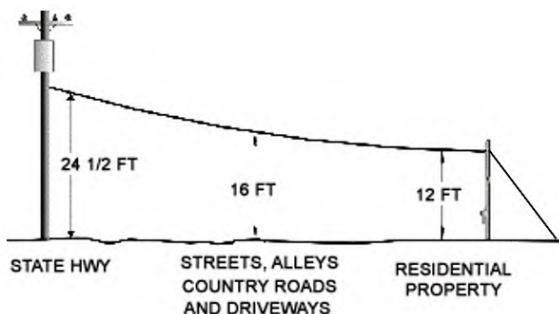

TEMPORARY & PERMANENT SERVICES

Mobile Home Services *(continued)*

CLEARANCE REQUIREMENTS

The National Electrical Safety Code (NESC®) and the National Electrical Code (NEC®) have established minimum overhead clearance requirements to ensure safe heights for different types of electrical conductors over various terrains depending on the type of usage expected. The diagram illustrates ground clearance requirements for a typical overhead permanent electric service. For additional information, refer to the latest NESC® and/or

NEC® codes. Your electrical inspector and LG&E's Service Representative will be able to assist you with a permanent service so adequate clearance is provided. Although LG&E provides the overhead service conductors, the customer must provide adequate clearance at the structure to ensure all applicable clearance requirements can be met.

RESPONSIBILITY

Customer-owned and installed equipment

(All equipment installed to LG&E specifications)

- Service pole and cable attachment provisions
- Meter base, meter enclosures and service disconnect
- Service entrance conductors (weatherhead and beyond)
- Ground conductors, rods, etc

Notes: Service neutral and meter base must be permanently grounded in accordance with NEC® guidelines.

LG&E-owned and installed equipment

- Utility service lines (to weatherhead on customer's structure)
- Connection to customer wiring
- Electric meter and metering transformers, if applicable

UNDERGROUND SERVICES

The customer must provide a suitable post, pedestal or other structure for mounting metering and associated service equipment. The minimum acceptable post size is six-inches by six-inches by eight feet long. This size may need to be increased to provide adequate surface area to mount the meter base, disconnect switch and other service equipment. Wooden poles and posts must be pressure or thermally treated with an LG&E-approved preservative. All service structures must be approved for use by LG&E.

Post installation must include all necessary bracing to prevent the meter base from swaying. Since stability is a concern with prefabricated pedestals, they are not recommended. You must obtain LG&E's approval before installing such pedestals. Metal posts, frames or pedestals can be used as an option to wooden poles or posts if approved by LG&E. These options do not diminish or eliminate the requirements for height above the grade for meter mounting. See drawing # **81 20 07** for post depth, height and other details in Drawings section of this handbook.

TEMPORARY & PERMANENT SERVICES

Mobile Home Services *(continued)*

RESPONSIBILITY

Customer-owned and installed equipment

(All equipment installed to LG&E specifications)

- Service support (post or pedestal) and bracing
- Meter base and disconnect
- Service entrance conductors
- Service line and conduit to the transformer or splice box
- Ground conductors, rods, etc.

Notes: Service neutral and meter base must be permanently grounded in accordance with NEC® guidelines.

LG&E-owned and installed equipment

- Transformer or splice box
- Utility secondary lines to customer's point of ownership
- (For service from pedestal)
- Connection to customer wiring
- Electric meter and metering transformers, if required

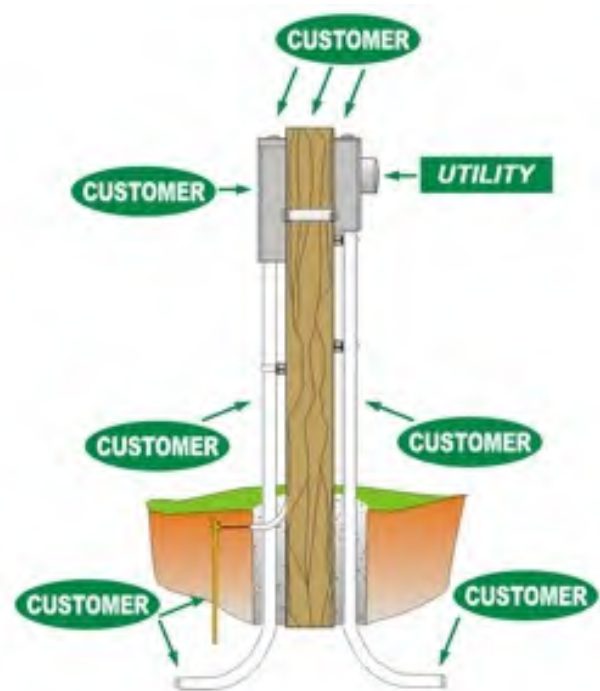

Please be aware of LG&E's requirements for a clear work zone area around utility equipment for service structures. Service structures should be located out of the reserved work zone area.

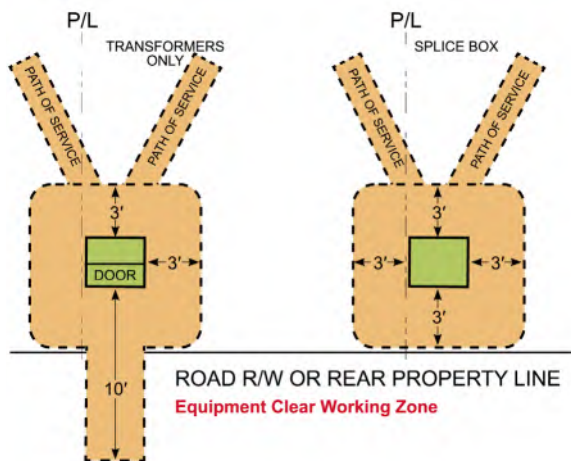

TEMPORARY & PERMANENT SERVICES

Multi-Family Structures

Multi-Family dwellings served under the residential rate must meet all of the provisions found in the section on permanent residential services. Some additional provisions apply as described below. The following definitions and classifications apply to multi-family services and developments.

SPECIAL DEFINITIONS/CLASSIFICATIONS

Dwelling unit—means a structure that is used as a home, residence or sleeping place by one or more persons maintaining a common household.

Multi dwelling unit—means a structure with more than one dwelling unit and not more than three stories above grade.

High-rise building—means any multi-family building with four or more stories.



Low Density Multi-Family installations— a single multi-family building of any size, or two or more multi-family buildings containing **less** than five (5) dwellings per building.

High Density Multi-Family installations—developments with two (2) or more buildings containing **not less** than five (5) family units per building.

LINE EXTENSIONS

The cost to provide service to multi-family buildings is dependent on many factors, including how far LG&E must extend lines to serve the building(s) and whether service is to be provided overhead or underground. Other factors include the number of buildings involved, the number of dwelling units per building, the number of floors in each building and the average density of dwelling units per acre. Single multi-family buildings and others meeting the definition of “Low Density” facilities will be treated

in the same manner as service provided to individual residences. Two or more buildings meeting the definition of “High Density” multi-family facilities may be subject to a reduction in the cost to provide service provided there is an average density of eight dwellings per acre. Service to high-rise buildings is complex and unique and must be addressed individually. An LG&E Service Representative will work closely with customers to identify all costs to provide service to multi-family installations.

SPECIAL METERING REQUIREMENTS

In all cases of multi family structures, individual meters shall be clearly and permanently identified to determine which dwelling unit service is supplied. Details on meter labeling requirements for multi-family structures can be found in section “Meter Information”. Should changes occur in wiring, location, etc., LG&E must be contacted and the change noted on the meter installation.

Individual meters are required for each newly constructed dwelling unit in a multi dwelling building except as excluded below:

Exclusions:

1. Transient multi dwelling units, such as hotels, motels, campgrounds, hospitals, nursing homes, convalescent homes, college dormitories, fraternities, sororities, boat docks and mobile homes without a permanent foundation and not connected to sanitation facilities.

2. Electricity used in central HVAC systems.
3. Electricity used in high-rise buildings.
4. Applicants who desire master metering on buildings for which master metering is prohibited may make a formal complaint to the Kentucky Public Service Commission. Applicant must prove the cost of individual metering is greater than the long-term benefits of individual metering to the consumers of the electricity at the building.

Residential rates are based on service to individual family dwelling units and are not applicable to multi family dwellings combined on a single meter. For each family unit to be billed under the applicable residential rate, each dwelling unit must have the electrical service metered separately. Any other metering configuration will result in billing under an appropriate commercial rate.



COMMERCIAL
& INDUSTRIAL
SERVICES

COMMERCIAL & INDUSTRIAL SERVICES

Introduction

The first step toward arranging for permanent Commercial or Industrial service is to follow the guidelines in the section entitled “Arranging for Electric Service”. The customer must contact LG&E and complete an application for electric service. The form can be completed online, lge-ku.com at LG&E’s walk-in customer service center (9th and Broadway) or by phone when you call the Business Service Center at **1-800-331-7370**. All other steps in the section “Arranging for Electric Service” must also be

followed. Some general information on arranging for permanent service can be found below.

While no typical configuration for Commercial or Industrial services can be devised, some general information on arranging for permanent service can be found below. However, drawings in Drawings section of this handbook outline basic service requirements.

Type Of Service

Two types of service are available, Overhead and Underground. Underground service is generally available to everyone. Specific exceptions include areas subject to high water or flooding and in areas where excavation may be limited due to soil/rock conditions. Overhead service is available if nearby utility facilities are overhead, except in areas specifically prohibited by local

ordinance. The customer is responsible for any additional costs associated with underground service when overhead facilities are available even when ordinance or other restrictions limit providing service overhead. It is the customer’s responsibility to be aware of any applicable local codes and ordinances.

Service Voltages

Service is normally provided at secondary voltage levels. However, under certain conditions, service can be provided at primary distribution or transmission voltages. In these cases, the

customer must construct and maintain all high-voltage lines and equipment and provide all voltage transformation equipment. The following nominal voltages are available:

SINGLE-PHASE SECONDARY SERVICE VOLTAGES	APPLICATION
120/240 volt 3-wire	Lighting and small commercial services
240/480 volt 3-wire	Overhead service only for non-residential customers

THREE-PHASE SERVICE VOLTAGES	APPLICATION
Secondary	
120/208 volt 4-wire grounded wye	Service from either overhead or underground facilities
240 volt 3-wire, corner grounded delta	Service from overhead facilities only
277/480 volt 4-wire grounded wye	Service from underground facilities only
480 volt 3-wire ungrounded	Service for motor loads only
Primary	
2,400/4,160 volt 4-wire grounded wye	Restricted Service Area
7,200/12,470 volt 4-wire grounded wye	Restricted Service Area
13,800 volt 3-wire impedance grounded	Restricted Service Area
34,500 volt 4-wire grounded wye	Restricted Service Area
Transmission	
69,000 volt 4-wire grounded wye	Restricted Service Area
138,000 volt 4-wire grounded wye	Restricted Service Area
345,000 volt 4-wire grounded wye	Restricted Service Area

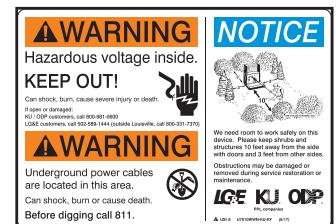

Special requirements apply for services greater than 480 Volts

COMMERCIAL & INDUSTRIAL SERVICES

Installation Costs

The installation costs for commercial or industrial, overhead or underground electric service depends on the size, type and location of LG&E's existing facilities and the type of service desired. These costs will vary according to LG&E's ability to

access existing utility facilities and/or the need to construct new facilities. Contact your LG&E Service Locator and/or Account Representative to discuss the specifics of your project.

Number/Type of Services

LG&E will provide each customer with a single-service voltage/configuration and will provide this service to a single location at the facility. Customers provided three-phase service are expected to provide any necessary voltage transformation needed for

lighting and outlet loads. At LG&E's discretion, a single-phase lighting service may be provided to three-phase power customers taking 240 volt or 480 volt 3-phase, 3-wire service.

Grounding

The NEC® requires one or more ground rods at the service entrance. Some Authorized Inspection Authorities require a minimum of two, so customers should consult with the Inspection Authority before construction begins. Ground rods need to meet the minimum requirements of the NEC® and should be eight feet

or longer. If multiple rods are installed, rods should be installed at least six feet apart. The grounding electrode shall be continuous from the service entrance main disconnect to one or both of the driven ground rod(s). All of the grounding bonds shall meet or exceed NEC® requirements.

Overhead Services (600 Volts or Less)

OVERHEAD CLEARANCE

The National Electrical Safety Code (NESC®) and the National Electric Code (NEC®) have established minimum overhead clearance requirements for electrical conductors that span over various types of terrain. The customer must ensure the attachment point on the structure, at the service mast or

service pole, as applies, will allow LG&E to install the utility service lines and maintain the required clearances. For additional information on clearance requirements, refer to the latest edition of the NESC®, NEC® or the Authorized Inspection Authority having jurisdiction.

OVERHEAD INSTALLATION

Customer-owned and installed equipment

(All equipment installed to LG&E specifications)

- Service attachment point, mast or service pole(s)
- Braces or guys
- Meter base and other required metering enclosures, supports and equipment
- Service entrance conductors and conduit
- Service disconnect and other required service entrance equipment
- Ground conductors, rods, etc.
- Lightning arrester (required for 480v delta secondary service. To be installed at service entrance point)

LG&E-owned and installed equipment

- Utility Service Cables To The Point Of Delivery
- Connections To Customer Wiring
- Electric Meters And Metering Transformers (If Required)

Note: Instrument transformers, if required, will be provided by LG&E, but installed by the customer. LG&E will provide and install any associated meter wiring.

COMMERCIAL & INDUSTRIAL SERVICES

Overhead Services (600 Volts or Less) *(continued)*

The Point of Delivery for overhead service is considered to be the transition from LG&E utility service lines to the customer's service entrance conductors. The transition typically occurs at the customer's weatherhead located on the service mast or service pole. If metering must be installed at a location remote from the point of demarcation, special arrangements must first be made with LG&E.

The customer's service entrance conductors must not be spliced.

Permanent electric services for commercial or industrial overhead installations are to be constructed in accordance with LG&E Standards and applicable codes, standards and regulations. Service entrance conductors must be marked with color-coded tape per NEC® specifications. Contact your LG&E Service Locator to discuss project details or to address any special requirements for the project.

Permanent Underground Service (600 Volts or Less)

UNDERGROUND CLEARANCE

The National Electrical Safety Code (NESC®) and the National Electrical Code (NEC®) have established minimum burial depths for the safe installation of underground electrical conductors for all wiring methods and all types of terrain. The customer should consider the installation and determine if minimum requirements will provide sufficient protection at all times from damage imposed by expected surface usage. If not, the customer

is expected to increase burial depth accordingly. LG&E also recommends the installation of concrete encased PVC for all customer cable systems to provide additional protection and to aid in service installation. For additional information on burial requirements, see drawing # 40 02 04 in Drawings section of this handbook.

CUSTOMER-PROVIDED FACILITIES FOR UNDERGROUND SERVICE

It may be necessary for LG&E to extend primary lines onto the customer's property when it is not practical to provide service from the property boundary. The length and nature of an underground service lateral will be governed by good engineering practices and shall be installed in such a manner that it is free of drainage fields, septic systems, pipes, areas of deep cultivation and other interference. The customer is responsible for providing all associated trenches, conduit systems, equipment pads, manholes, etc. located on the customer's property that are required for the purpose of providing service. The customer also must provide the secondary service cable. LG&E will install all service-related metering equipment and cable, except service cables, once these facilities have been installed and approved.

All customer-provided facilities must be installed to LG&E standards and be inspected and approved for use by

LG&E before service can be provided. LG&E requires twenty-four (24) hours notice to schedule an inspection of customer-provided facilities. The customer will own and maintain all customer-provided facilities, but LG&E will maintain exclusive control over their access and use. No access will be granted to any customer-provided facilities used to provide service. No other facilities or other utilities will be placed in customer-provided cable systems under the exclusive control of LG&E without the expressed approval of LG&E. Under some conditions, LG&E will allow a single trench to be shared by other utilities, such as, CATV and telephone provided other utility lines do not enter manholes, splice boxes or enclosures or are placed under LG&E equipment pads. No customer cables, equipment or other facilities will be allowed to share the service trench. See your LG&E Service Locator for additional information.

COMMERCIAL & INDUSTRIAL SERVICES

Permanent Underground Service (600 Volts or Less) *(continued)*

UNDERGROUND INSTALLATION

Customer-owned and installed equipment

(All equipment installed to LG&E specifications)

- Customer-owned cable systems (service entrance conductors)
- Cable systems provided by the customer for LG&E's use (conduit, manholes, pads, enclosures, etc.)
- Meter base and other required metering enclosures, supports and equipment
- Service disconnect and other service entrance equipment
- Ground conductors, rods, etc.

LG&E-owned and installed equipment

- All service equipment including padmount transformer, switchgear, splice boxes, etc.
- Utility primary and secondary cables

- Connections to customer wiring
- Electric meter and instrument transformers (if required)

Note: Instrument transformers, if required, will be provided by LG&E, but installed by the customer. LG&E will provide and install any associated meter wiring.

The Point of Delivery for underground service at secondary distribution voltages is considered to be at the secondary lugs of LG&E's padmount transformers when the transformer is on private property or at a secondary enclosure at the customer's property line if the transformer is in a public right-of-way.



LOCATION OF EQUIPMENT

The customer must provide a location suitable for the installation of the padmount transformer, switchgear and other associated service supply equipment. The area must be free from obstructions, provide adequate access, work and safety clearances. The customer must provide and install protective devices (see drawing # 04 10 04 in Drawings section of this handbook) if the area is subject to vehicular traffic or potential

damage from other mechanized equipment.

Utility equipment will not be located inside of buildings or in below ground vaults unless no other options to provide service exist. For more complete information on equipment location requirements, see part 1 of this handbook titled "Requirements for Electric Service Equipment."

SPECIAL REQUIREMENTS—TRANSFORMERS AND OTHER OIL-FILLED EQUIPMENT LOCATED OUTSIDE BUT NEAR BUILDINGS

LG&E restricts the location of transformers and other oil-filled equipment near buildings to the following:

- 1Ø Transformers 75 kVA or less shall be located at least 5 feet from building walls.
- 1Ø Transformers 100 kVA to 250 kVA shall be located at least 10 feet from building walls.
- 3Ø Transformers 75 kVA to 500 kVA shall be located at least 15 feet from building walls.
- 3Ø Transformers 750 kVA to 3000 kVA shall be located at least 25 feet from building walls.

Placement of transformers and other oil-filled equipment closer to buildings will require a fire containment enclosure and/or modifications to the building to reduce the potential fire risk. Fire containment requirements for oil-filled equipment can be found on Drawing # 42 06 20 in Drawings section of this handbook.

Note: The fire containment requirements do not meet the environmental requirements for oil containment when required.

In addition to oil-filled equipment limits near buildings, other requirements for equipment location will apply for special installations near pools, fire hydrants, sprinkler valves, standpipes, fire escapes and building access openings, and any facilities used to dispense or store hazardous liquids or gases.

Contact your LG&E Service Locator for requirements and possible exceptions to these rules and/or contact the State Fire Marshall, Department of Housing, Buildings and Construction, Division of Fire Prevention at (502) 564-3626.



SPECIAL PROCEDURES



SPECIAL PROCEDURES

Overhead to Underground Service Conversions

CONVERSION COSTS

If a customer is adding load to a home or business, and the additional load will require LG&E to change out the existing overhead service, the customer will have the option of either staying with an overhead service or going to an underground service with no customer contribution required.

If the existing overhead service is large enough to handle the additional load, the customer still has the option of going with an underground service, but the customer will have to pay full cost for all LG&E expenses.

In cases where a customer wishes an underground service solely for aesthetic reasons, the customer will have to pay full cost for all LG&E expenses. In all cases, residential or commercial, single-phase or three-phase, if the customer chooses an underground service, the customer must provide the splice box approved by LG&E and install it according to the latest construction standard drawing.

RESPONSIBILITIES

The figure to the right identifies the shared responsibilities between LG&E and the Customer for a typical conversion of Overhead to Underground electrical service.

Customer-owned and installed equipment

(All equipment installed to LG&E specifications)

- Meter base, metering enclosures and disconnect (up to code)
- Service lines and conduit to the transformer or splice box
- Ground conductors, rods, etc.

LG&E-owned and installed equipment

- Utility secondary lines to the customer's point of ownership
- Connections to customer wiring
- Electric meter and metering transformers, if required

Customer-installed and LG&E-owned equipment

(All equipment installed to LG&E specifications)

- Splice box

Notes

Instrument transformers, if required, will be provided by LG&E, but installed by the customer. LG&E will provide and install any associated contact meter wiring.

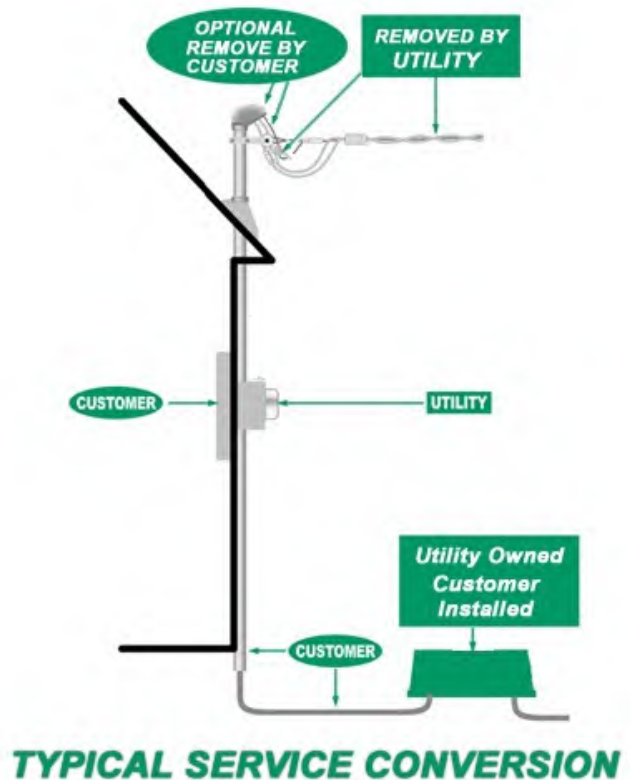

CONSTRUCTION STANDARDS

All residential Overhead to Underground service conversions will be constructed to LG&E Standard Drawing # 51 04 03 found in Drawings section of this handbook.

SPECIAL PROCEDURES

Rewire Procedure

If an existing electrical service is to be rewired, certain standards and specifications must be followed. If you are going to have the work done, it is recommended that a qualified licensed electrical

contractor be used. All work must be completed to the requirements of the NEC® the NESC® and the Authorized Inspection Authority.

- Regardless of whether a licensed electrician or the owner performs the work, an electrical permit must be obtained and electrical work must pass all required electrical inspections before LG&E can make any changes to or reconnect the service.
- Before proceeding with any rewiring work, the responsible party must contact the appropriate LG&E Service Locator for a meter location. To determine the appropriate Service Locator, contact Customer Care Service at 502-589-1444 (Outside Louisville at 1-800-331-7370) for residential rewiring work or the Business Service Center at 502-627-3313 (Outside Louisville at 1-800-331-7370) for commercial/industrial work.
- The NEC® requires all new and upgraded residential services to be rated a minimum of 100 amps. LG&E requires all residential services to be 120/240 volt, single-phase 3-wire.
- Besides issuing a meter location, the Service Locator will also advise the customer about such things as the acceptable meter base height, location, etc. if necessary. Construction standard drawings are provided in this handbook detailing the most common service requirements. Clearance of three feet is required in front of any meter and the customer must own that area. The area two feet on either side of the meter location must be clear of any obstructions. A minimum of three feet of clearance is required between the electric meter base and a gas meter (outside to outside).
- An overhead electric service line cannot pass in front of a window unless there is a minimum horizontal clearance of 36 inches. Electric service cannot pass over a chimney or roof vent.
- An overhead service pole will typically be required for 200 amp services (and below) if the service length exceeds 100 feet and when adequate clearance cannot be obtained for services less than 100 feet. The maximum length with a service pole will be 150 feet provided voltage drop and flicker requirements can be met.
- A service pole will also typically be required for overhead service runs over 70 feet for services larger than 200 amps. The maximum distance with a service pole for this size service will not exceed 100 feet provided voltage drop and flicker requirements can be met.
- After the service has been inspected, the Inspecting Authority will notify LG&E and, in most cases, the service will be connected on the following working day.
- On the day the service is scheduled to be connected, LG&E personnel must be able to enter the home or business. They must see the approval (green sticker) from the Authorized Inspection Authority and have access to the main breaker.



SPECIAL PROCEDURES

Burnout Procedure

Normally, electrical service must be disconnected whenever a customer's electrical service or equipment has been extensively damaged. The process for electrical repair work is the same as for any other electrical work. Before service can be restored, the work must be permitted, inspected and approved by the Authorized Inspection Authority. Service can then be permanently restored once the Authorized Inspection Authority notifies LG&E that the work has been approved.

The burnout procedure outlined below is a special process. It allows LG&E to restore full or partial service to damaged services

while repairs are being made. The burnout procedure is only used when it is impractical to obtain a permit before starting repairs, such as when the damage occurs outside normal working hours for the Authorized Inspection Authority. If, in the opinion of a qualified licensed electrical contractor, the service can be made safe through immediate or partial repairs, the contractor can request the Authorized Inspection Authority to allow full or partial service to be restored on a temporary basis. No service will be restored without the approval of the Authorized Inspection Authority. The burnout procedure is outlined below:

- Whenever an electrical service has been damaged, contact LG&E at 502-589-1444 (Outside Louisville at 1-800-331-7370) immediately. LG&E will dispatch a representative to the premise. The technician will disconnect the service, make the area safe and advise the customer of follow-up steps that need to be taken.
- The customer should contact a licensed electrician as soon as possible. The electrician will determine if the burnout procedure is appropriate. If so, the electrician will advise the customer and make the service safe so service can be restored. The electrician will request the approval of the Authorized Inspection Authority to reconnect the service with a "Five-Day Letter". A sample of a "Five-Day Letter" is shown below.

The Five-Day Letter will only be used when the service can be made safe while repairs are ongoing.

The "Five-Day Letter" is an agreement to restore emergency service in lieu of a permit and inspection. Once notified of approval by the Authorized Inspection Authority, LG&E is authorized to accept this agreement as a temporary measure to provide the customer with electrical service. Until such time that the Authorized Inspection Authority approves final repairs, the customer assumes all liability and responsibility for damage to life and property.

- After the Authorized Inspection Authority notifies LG&E of its approval to restore service, LG&E will return to the premise to temporarily reconnect the service. LG&E requires the "Five-Day Letter" be filled out and signed before reconnecting the service.

- This "Five-Day Letter" is only valid for a period of five (5) working days. A permit must be obtained within this period, and it is generally expected that the work will be completed within this time. However, the Authorized Inspection Authority may, upon request, grant an extension.
- Should any of the above requirements not be met, LG&E is authorized to disconnect the service without further notice.
- After the permanent repair work is complete and the service has been inspected, the Authorized Inspection Authority will notify LG&E and, in most cases, the service will be permanently reconnected as soon as possible.
- On the day the service is scheduled to be connected, LG&E personnel must be able to enter the premise. They must see the sticker of approval (green sticker) from the Authorized Inspection Authority and have access to the customer's main breaker.

SUPPLEMENTAL INFORMATION



SUPPLEMENTAL INFORMATION

Reading Your Own Meter

Your electric meter is like an odometer on a car. Instead of measuring miles, it measures energy in kilowatt-hours of use.

One kilowatt-hour is equal to the amount of energy needed to supply 1000 watts (10 - 100 watt light bulbs) of load for one hour.

The meter keeps count of the total amount of electricity used to operate all of your electrical appliances. The electric meter face usually has four or five dials. Each dial has 10 numbers and a

pointer. The pointer turns when electricity is being used; it can move so slowly that you can barely see the dials turn.

The dials are read from left to right. When the pointer is between numbers, record the number that the pointer has passed. This will always be the smaller number. As shown in the figure below, each dial rotates opposite of the one before it, so some practice may be required to read the meter correctly.

The examples below show how to read a meter correctly.

Example #1:

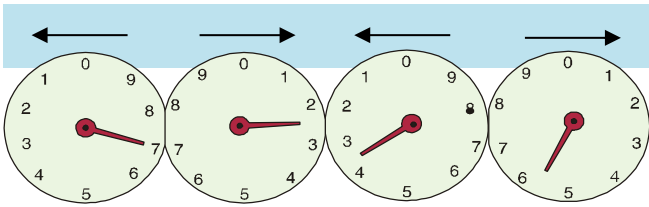

The correct reading for this meter is: **7,235.**

Example #2:

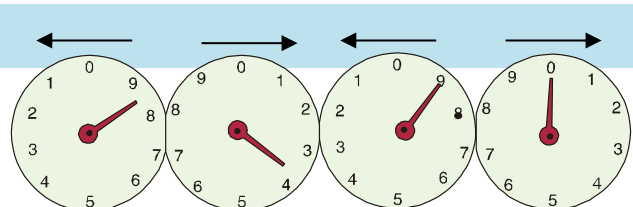

The correct reading for this meter is: **8,390.**

To check one day's energy use, make two readings 24 hours apart and subtract the first reading from the second. You can add daily results for monthly amounts or read the meter at the beginning of the month and then subtract that reading from a reading taken at the end of the month. If you read your meter on the same days as LG&E, you can check the monthly usage that will be charged on your bill. In addition to cost information, your bill will always show total usage in kilowatt-hours.

Small differences in usage should be expected if you do not read the meter at exactly the same time LG&E reads the meter each month. However, it should be possible to identify a large discrepancy in usage.

If you feel the amounts that are displayed incorrect, contact LG&E's Customer Service Department at 502-589-1444 (Outside Louisville at 1-800-331-7370).

For example:



$$\begin{array}{r}
 40967 \\
 - 40772 \\
 \hline
 = 195 \text{ kwh used}
 \end{array}$$

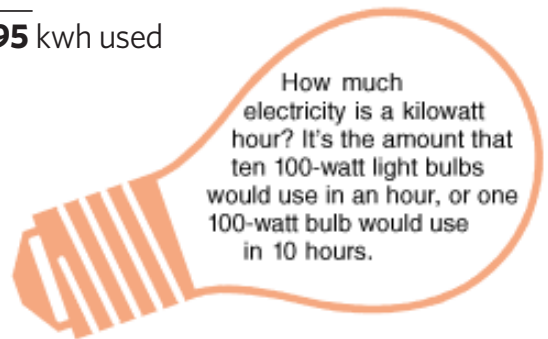

How much electricity is a kilowatt hour? It's the amount that ten 100-watt light bulbs would use in an hour, or one 100-watt bulb would use in 10 hours.

SUPPLEMENTAL INFORMATION

Emergency Power Sources

REQUIREMENTS FOR EMERGENCY AND STANDBY GENERATORS

All permanently installed generators and other types of standby power sources and their associated interface wiring are to be installed in accordance with the NEC®. Such installations are subject to inspection and approval by LG&E and are subject to removal from the premise wiring if not operated and maintained in a safe manner. The customer must notify LG&E whenever a permanently installed standby system has been installed.

Permanently installed standby power systems are to be connected to the customer's wiring system by a permanently installed transfer switch intended for that purpose. Transfer switches can either be manually operated or automatically controlled. Wiring work and installation of the transfer mechanism associated with the standby power source shall be performed by a licensed electrical contractor. The transfer switch or

switching system shall disconnect all ungrounded service conductors connected to the LG&E system prior to connecting the standby power system to the conductor's supplying load. Additionally, the transfer switch is to be designed and installed so that connecting the standby system to the LG&E system is prevented for any mode of operation.

When in the position which disconnects the LG&E supply, the transfer switch must have a visible opening and must be lockable in the disconnected position. The transfer switching schemes must meet applicable building and electrical codes.

Portable generators shall likewise not be interconnected to the LG&E supply except when the interface is made through a permanently installed transfer switch.

PORTABLE GENERATOR SAFETY

When power is out for any reason, portable generators can be used to temporarily supply electricity. But if used improperly, portable generators can be dangerous to the customer and to LG&E personnel working to restore service. Here are some tips for safe operation:

- Portable generators are designed to supply power directly to one or more appliances. Never "rig" a portable generator into your home wiring system. The voltage can back feed into the Utility system and be transformed to very high levels. This can overload and damage the generator. It can also seriously injure LG&E personnel working to restore service on what is expected to be a de-energized line. When power is restored, an electrical fault can occur because the generator's voltage will not be in phase with the LG&E system voltage. This can seriously damage the premise's electrical system and/or the generator.
- Only operate portable generators in ventilated areas. Portable generators produce carbon monoxide fumes that are potentially lethal in enclosed areas.
- Use heavy-duty extension cords with your appliances and your portable generator, and don't overload an extension cord with too many appliances.
- Portable generators aren't intended to run your entire home electrical system. Know which equipment you'll need in an emergency situation, and only plug those items into your generator. Do not overload the generator and make sure the protective devices on the generator work correctly.

Permanent generators, as stated above, require a device called a transfer switch that prevents them from being connected to LG&E's electric system. If you plan to permanently install a portable generator, be sure to have your electrical contractor install the proper transfer switch.

For additional information, use the link below to the Consumer Product Safety Commission web page on generator safety: [cpsc.gov](https://www.cpsc.gov)



SUPPLEMENTAL INFORMATION

Landscaping And Vegetation Near Electrical Lines

CLEARANCE TO OVERHEAD LINES

Because trees and other vegetation touching power lines are the most frequent cause of power outages, care must be taken not to plant anything near overhead electrical lines that will grow tall enough to reach the line. When planting trees near power lines, work with an arborist or the nursery where you purchase your trees to choose a tree type that will have a growth pattern suitable for the distance to where it is planted (from overhead lines).

Doing so helps minimize power outages and unsightly trimming that may become necessary to provide clearance for power lines as the tree grows. Before planting, visualize your tree or shrub at maturity, 10 or 15 years from now. How tall will it be? How wide will the spread of the branches be? For this discussion, trees are categorized in zones.

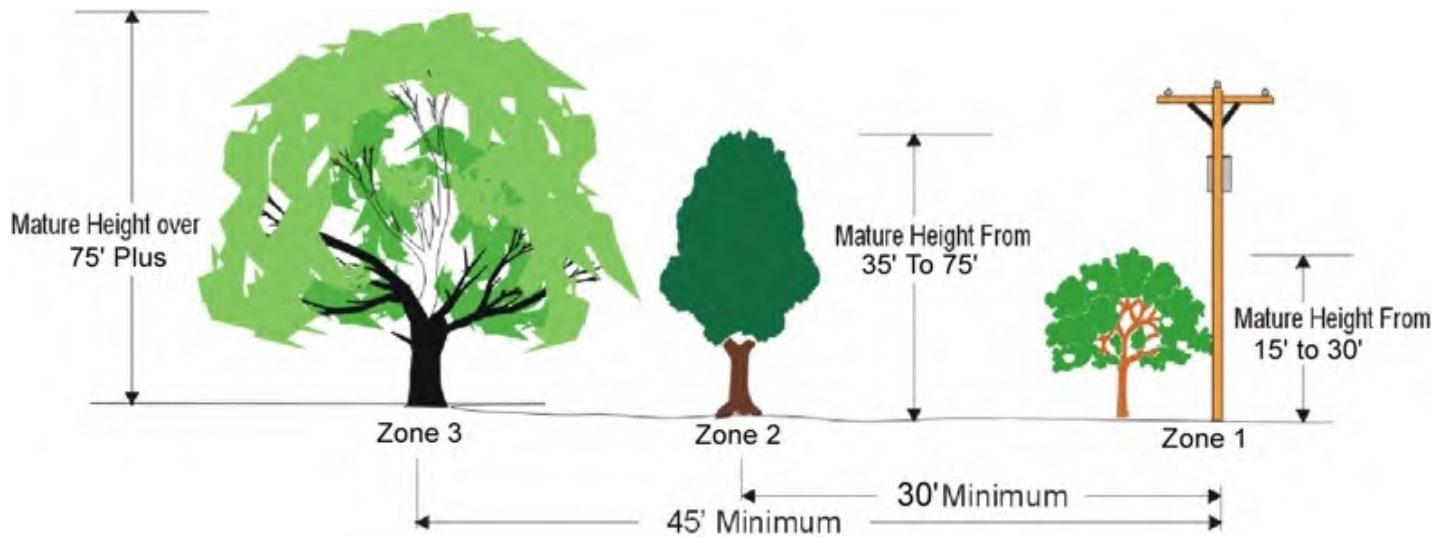

The tree's mature height should be less than 30 feet if it is to be planted within 15 feet of an overhead electric line.

ZONE 1 TREES

When planting less than 15 feet from overhead power lines, choose small-growing trees and bushes that are adaptable to this area and grow no taller than 15 to 30 feet. These trees and bushes will require a minimal amount of pruning as they grow.

ZONE 2 TREES

When planting at least 30 feet from power lines, slightly larger trees may be appropriate. Work with your local nurseries to choose a medium-sized tree that will mature to a height no taller than 75 feet.

ZONE 3 TREES

Visualize the tree at its full size, height and width. Large trees, such as oaks, often spread out considerably as they grow. With proper planning, you can have a variety of beautiful trees of varying sizes in and around power lines without having to worry about them causing problems in the future. Plant the saplings of large-growing species at least 45 feet from power lines in order to avoid pruning problems in the future.

SUPPLEMENTAL INFORMATION

Landscaping And Vegetation Near Electrical Lines *(continued)*

TREE SAFETY

Choosing the correct tree to plant near overhead lines will provide for a safe and attractive installation that will not require unsightly trimming. However, many older trees are located too close to overhead lines. LG&E trims these trees only to the extent necessary to provide clearance for the overhead lines.

LG&E strongly recommends the use of professional tree trimmers certified for electric line clearance work when trimming or removing trees that are near power lines. Other professional trimmers can be used provided no part of the tree is within 10 feet of the line. Trimming and removal work can be extremely dangerous. Tree limbs, ropes and most ladders are conductors of electricity. If these or any other objects come into contact with a power line, anyone working on or near the tree will be at risk. The customer is also responsible for any damage done to power system lines and equipment caused by the work.



Because tree limbs can conduct electricity, never let children climb or play in trees near power lines. Because trees are fairly good conductors of electricity, children do not have to actually touch the line to be shocked. If a

limb sags down and comes into contact with a power line, the whole tree can become energized and can even injure someone standing on the ground nearby.

CLEARANCE TO UNDERGROUND LINES

Even when electric lines are placed underground, you must be careful when planting trees, gardens and doing other types of landscaping work. Few customers know the exact location or depth of underground utility lines or the service lines (power, gas, telephone, CATV, etc.) coming to their house. Whenever underground utilities are nearby, you have to be careful to dig safely.

Although most electrical lines should be placed below the level needed for gardens and smaller plantings, other utilities may not be as deep. Digging for trees and other larger plantings can easily reach the expected depth of underground electric lines. Additionally, ground settling, soil erosion and grade changes often reduce the depth of underground lines.



If you know you will be digging near underground lines or don't know where utility and customer lines are placed, call Kentucky 811 (dial 8-1-1) before you dig. Kentucky 811 will coordinate with LG&E and other member utilities of your plans to dig so that the utilities can locate their underground lines and, in some case, even the customer's service lines running to the home. This is a simple, no-cost step to reduce the risk of injury or costly damage to utility facilities.



Always Call Before You Dig!

SUPPLEMENTAL INFORMATION

Landscaping And Vegetation Near Electrical Lines *(continued)*

PLANTING NEAR ELECTRICAL EQUIPMENT

Customers often place landscape plantings around utility equipment so it cannot be seen. However, LG&E has specific clear space requirements for such plantings, even small plants, near its padmounted electrical equipment. Planting too close to equipment can delay service restoration and present a safety hazard to both electrical workers and customers. LG&E employees and contractors are authorized to trim or remove any plantings that interfere with safely working around electrical equipment. If the offending plantings are found during routine inspections, LG&E will notify the customer and the customer shall remove the plantings. In either case, LG&E will not be responsible for any losses or damages resulting from trimming or removal of plantings that interfere with safe access to utility equipment.



To summarize:

- Don't plant anything directly under power lines.
- Plant only low-growing shrubs or hedges within 10 feet of electric lines.
- Trees that grow to heights of up to 75 feet should be planted at least 45 feet away from electric lines.
- Where electric service is underground, don't plant anything within 10 feet of the pad-mounted transformers. Remember; find out where all underground utilities are located before digging.
- Don't plant trees in the right-of-way of high capacity transmission lines.

Minimum Clearance for Padmount Transformer

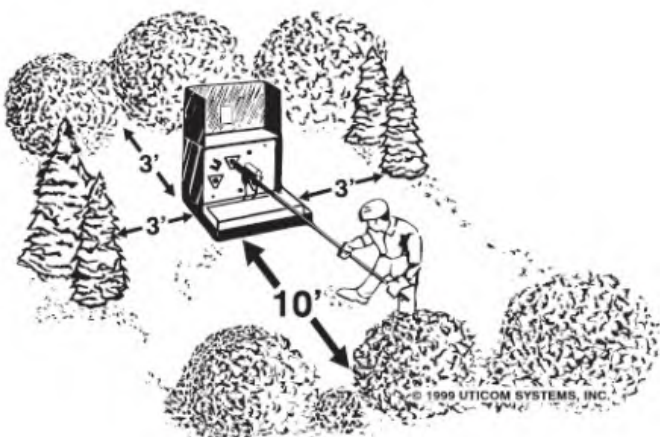

Customers should contact LG&E at 502-589-1444 (Outside Louisville at 1-800-331-7370) if they have any questions concerning planting near electrical lines or equipment.

“Where there is ground-mounted electrical equipment, there are underground electrical lines nearby.”



SERVICE RELATED
DRAWINGS

DESCRIPTION OF DRAWINGS

Drawing #	Description
Zip Code Map	Zip Code Area Map for Service Centers
Load Data Sheet	Electrical Load Data Submittal Sheet
02 10 20	NESC Clearances of Wires, Conductors and Cables Passing Over or Near Swimming Pools
04 10 04	Pole, Guy and Pad Protection
12 02 10	Recommended Mobile Home Individual Underground Service
12 02 12	Farm Multi-Service and Individual Mobile Home Meter Installation
12 10 02	Requirements for Overhead 120/240V Temporary Service
40 02 04	Concrete Encased Duct Layouts and Trench Dimensions Not Including Street Lights
42 06 04	Standard Pad Installation for 3Ø Transformers 75kVA to 3000kVA
42 06 20	Padmount Transformer Separation From Buildings and Fire Protection
42 06 22	Typical Concrete Pad Installation for 4 Compartment Deadfront Switchgear
42 06 24	Deadfront Switchgear Box Pads
51 04 03	1Ø Overhead to Underground Service 400A Max
51 04 05	3Ø Overhead to Underground Service 800A Max
51 06 06	Underground Parallel Secondary Installation
52 01 06	Requirements for Underground
52 10 02	Requirements for Underground 120/240V Temporary Service
81 10 02	Minimum C.T. Enclosure Size Using Up to 5 Cables Per Phase 120/240V 1 Phase 3W and 120/208V Network >400A-1200A
81 10 03	Minimum C.T. Enclosure for 1 or 2 Cables Per Phase —240V 3Ø 3W >400A-800A Max
81 10 05	Minimum C.T. Enclosure for 1 or 2 Cables Per Phase —480V 3Ø 3W >200A-800A Max
81 10 07	Minimum C.T. Enclosure for 1 or 2 Cables Per Phase —120/208V 3Ø 4W and 277/480V 3Ø 4W <800A
81 10 10	Minimum C.T. Enclosure for Up to 5 Cables Per Phase —240V 3Ø 3W >800A-2000A Max
81 10 11	Minimum C.T. Enclosure for Up to 5 Cables Per Phase —480V 3Ø 3W 2000A Max
81 10 12	Minimum C.T. Enclosure for Up to 5 Cables Per Phase —120/208V 3Ø 4W and 277/480V Ø 4W >800A-2000A Max
81 10 30	Switchgear Metering Requirements 3Ø 3W With Window C.T.'s
81 10 32	Space Requirements for Metering Window Type Current Transformers
81 10 38	Instrument Meter Pedestal
81 10 41	Typical 400 Amp Meter Base with Class 320 Meter —120/240V 1 Phase 3W

DESCRIPTION OF DRAWINGS

81 20 02	Typical 200-400A Meter Base for Overhead Service
81 20 03	Multi-Metering Numbering
81 20 05	Multi-Family Dwelling Individual Metering Overhead
81 20 06	Typical Meter Base for 1Ø Underground Residential Service —400A and Below
81 20 07	Typical Post Mounted Installation for 1Ø Service for Mobile Home
81 20 10	Typical Meter Base for 1 Phase and 3 Phase Overhead/Underground Service—200A Max
81 20 11	Typical 480V 3 Phase 3W Underground Delta
81 20 12	1 Phase and 3 Phase 480V Self-Contained Meter Base with Loadbreak Disconnect—Up to 200A

LG&E SERVICE CENTER ZIP CODE BOUNDARIES

EAST SERVICE CENTER

10300 Ballardsville Rd.

Louisville, KY 40241

Other areas covered by East Service Center but are not shown include:

Buckner	40010	Goshen	40026	Pewee Valley	40056
Crestwood	40014	Harrods Creek	40175	Westport	40077
Eastwood	40018	Lagrange	40031		
Fisherville	40023	Pendleton	40055		

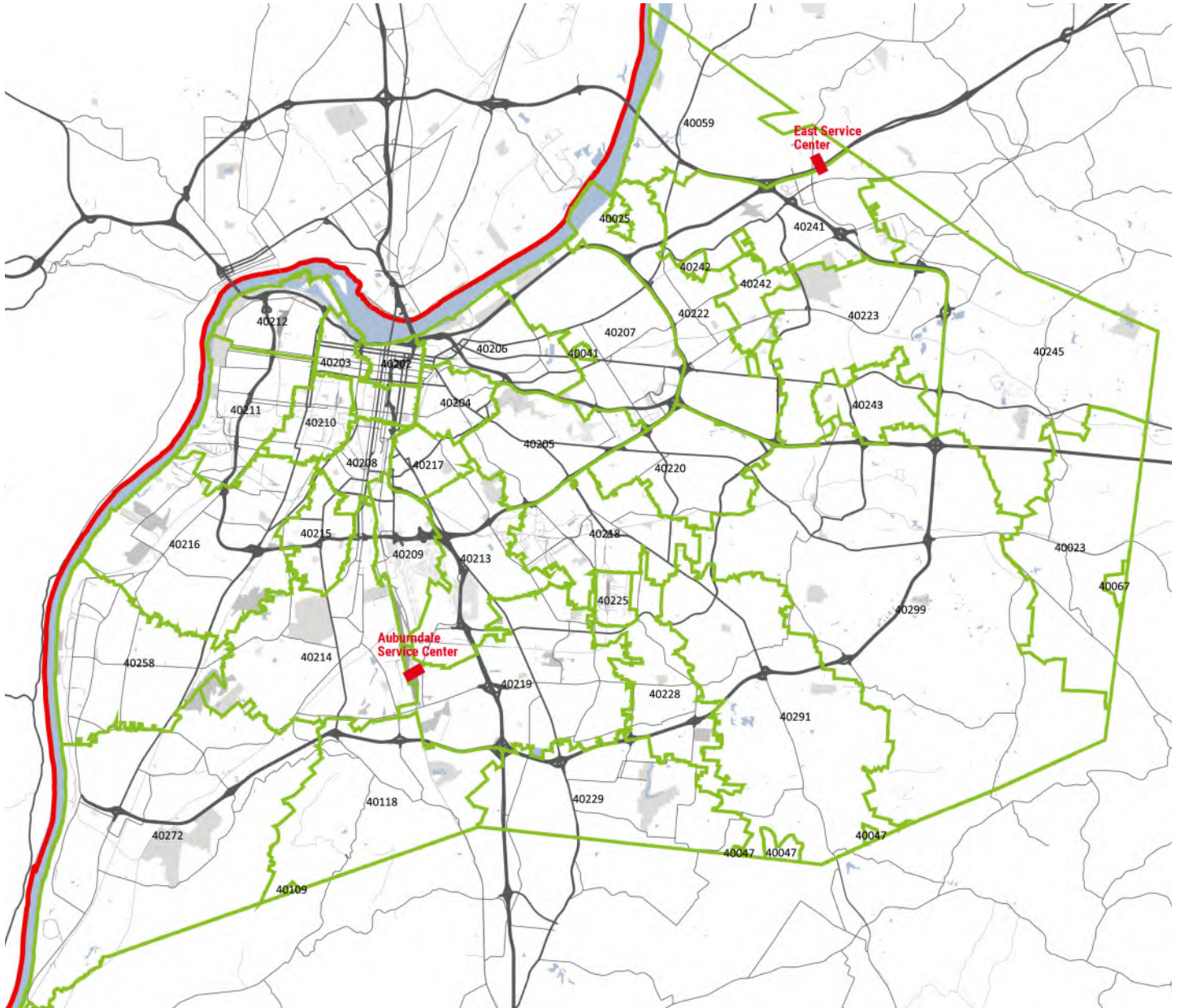

AUBURNDALE SERVICE CENTER

6900 Enterprise Dr.

Louisville, Ky 40214

Other areas covered by Auburndale Service Center but are not shown include:

Brandenburg	40108	Muldraugh	40155	Vine Grove	40175
Brooks	40109	Mt. Washington	40047	Westpoint	40177
Fort Knox	40121	Shepherdsville	40165		



Electrical Load Data Sheet

Please Provide Two Copies of Site Plan



*Facility Name: _____ *Date: _____
 *Address: _____ *City/State/Zip: _____
 *Directions or nearest intersecting Street: _____

This sheet should be submitted in addition to the LG&E Gas Load Data Sheet, if applicable. This sheet does not fulfill the requirement of an application for service. You must contact LG&E Customer Service at (800) 331-7370 or KU Customer Service at (800) 981-0600 (residential) or (800) 383-5582 (business) to apply.

For LG&E customers, fax your completed load sheet to (502) 217-2083 or email to new.biz@lge-ku.com.

For KU customers, call the KU BSC line at (859) 367-5839 or email to BSCMoves@lge-ku.com.

Items with an asterisk * or in RED boxes are required information. Failure to provide this information may result in delays regarding your project.

Electric Service Data

Service Request Type: New Construction Existing Overhead to Underground Conversion

Anticipated Service Date for Permanent Service: _____ Temporary Service Needed: Yes No Date: _____

Electric Service Type: Overhead Underground (padmount) Underground (splice box LG&E) Underground (from pole KU)

*Entrance Size: _____ A Conduit # & Diameter: _____ Conductor Size/# of Sets: _____

Facility Type: Multi-Family Residential Commercial Industrial Municipal

Facility Comments for Multi-Family (e.g. # of units per building): _____

Facility Total Sq-Ft (as per building): _____ # of Floors: _____ Sq-Ft of Comfort Conditioned Area: _____

Facility Heated with: Gas Electric Water Heating: Gas Electric Tons-A/C: _____ # of Units: _____

This facility's intended use will be (e.g. residential, office space etc.)? _____

Does this project involve any of the following?

Electric Vehicle Charging: Yes No # of Level 2 (1Ø) chargers _____ # of Level 3 (3Ø) chargers _____ Total kW _____

Distributed Generation: Yes No kW if Yes _____ Type (solar, wind, backup generator, etc.) _____

Energy Storage: Yes No kWh if Yes _____ kWh if yes _____

Will any resource above backfeed electricity onto the distribution system? Yes No

Load & Voltage Data

Service Types Available					
Please Check Type					
Service Voltage/Type		LG&E		KU	
		OH	UG	OH	UG
<input type="checkbox"/> 120/240V	1Ø 3W	YES	YES	YES	YES
<input type="checkbox"/> 120/208V	3Ø 4W	YES	YES	YES	YES
<input type="checkbox"/> 240V	3Ø 3W	YES	NO	NO	NO
<input type="checkbox"/> 120/240V	3Ø 4W	NO	NO	YES	YES
<input type="checkbox"/> 277/480V	3Ø 4W	NO	YES	YES	YES
<input type="checkbox"/> 480V	3Ø 3W	YES	NO	NO	NO
OTHER: _____					

What will the **true estimated peak demand** for this service be in _____ kW?

Connected Loads	1 Phase kW	3 Phase kW
Space Heating	_____	_____
A/C Heat Pump	_____	_____
Air Handler	_____	_____
Lighting	_____	_____
Water Heating	_____	_____
Cooking	_____	_____
Refrigeration	_____	_____
Welding +	_____	_____
Misc./Recept/LEV	_____	_____
Total New Load	_____	_____
Existing Load	_____	_____
Total Load	_____	_____

+ may require special consideration

Motor Data:

Largest Motor: _____ Reduced Start: Yes No Type if Yes: _____

HP: _____ Voltage: _____ Phase: _____ Part Winding & Ratio _____ Wye-Delta _____

FLA: _____ LRA: _____ Solid State Ramp Setting % _____ Current Limit % _____

Other, please describe _____ Autotransformer & Tap Setting % _____

Contact Information *

*Customer/Owner: _____ *Contractor/Developer: _____
 *Phone: _____ Email: _____ *Phone: _____ Email: _____
 *Address: _____ *Address: _____
 *City/State/Zip: _____ *City/State/Zip: _____
 Comments: _____
 *Submitted By: _____ Date: _____

NESC SECTIONS 234 AND 351 (NESC 2017)

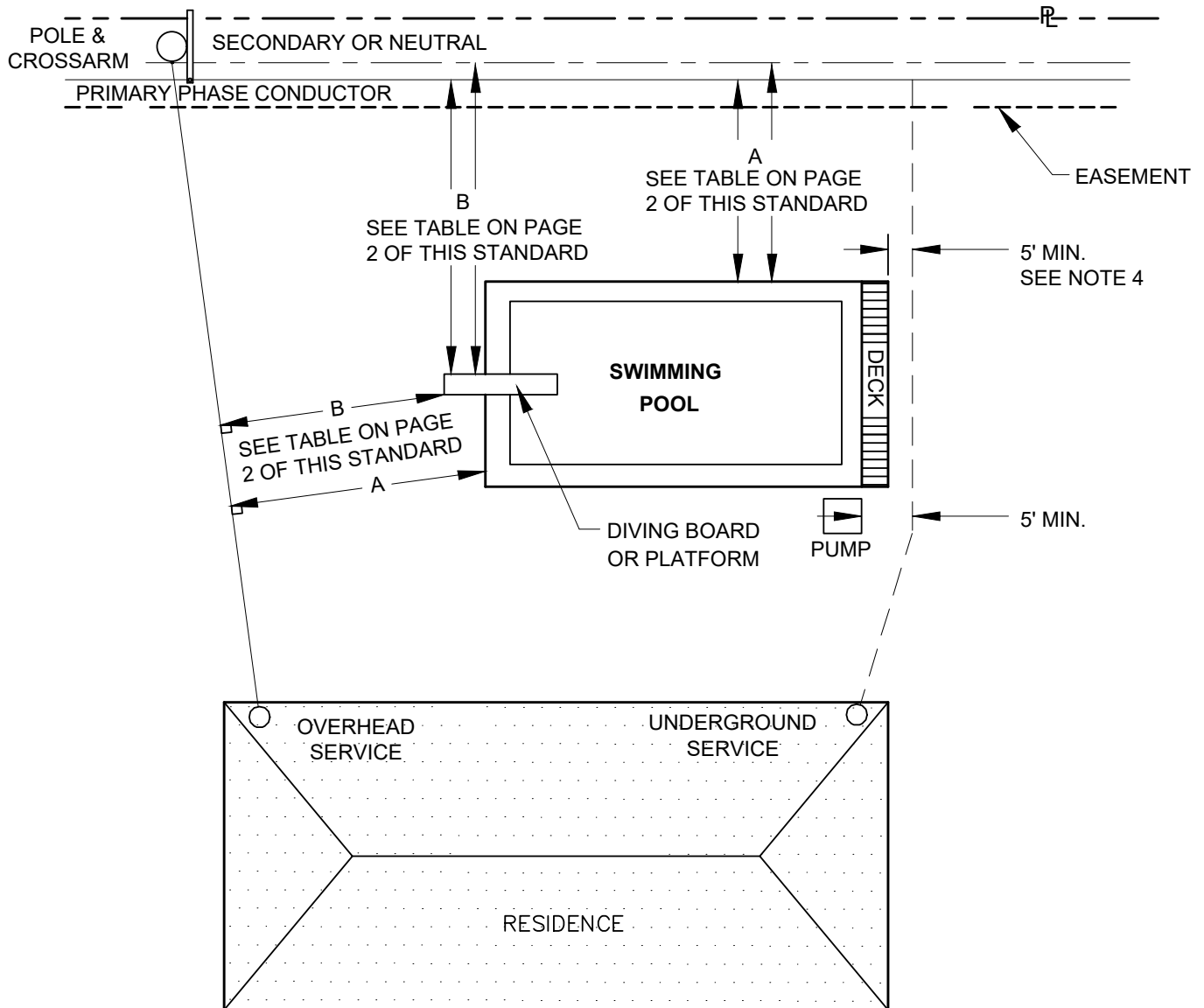

APPLICATION:

These clearance requirements apply to all pools and also to supervised swimming areas including beaches, waterways, etc. where swimming is allowed and rescue poles are used. For unsupervised swimming in other water areas, Rule 232 (standard 02 10 06) applies. Contact the Standards Group for clearances to lines greater than 22kV phase-to-ground. Exception: These clearances do not apply to pools that are fully enclosed by a solid or screened non-retractable permanent structure.

NOTES:

1. Clearance to each conductor in the pool area must be checked. The clearances listed in this standard are **minimums**. Additional clearance may be required for future changes in grade, leaning poles, etc. Vertical clearances to overhead lines apply under whichever conditions of conductor temperature and loading produce the closest approach:
A) 120°F, no wind, final sag; B) Maximum operating temperature, no wind, final sag; C) 32°F, with 1/4" ice, no wind, final sag; D) Minimum operating temperature, no wind, initial sag.
2. Installation of new conductors over existing pools should be avoided wherever possible, even when NESC clearance is obtainable. Pools installed under existing lines which result in a code violation must be brought in compliance by relocation of the pool or line or, if necessary, ensuring adequate clearance over the pool. It is normally the customer's responsibility to correct code violations caused by placing a pool under existing utility lines.
3. Multiplex service drops (triplex) less than 750 V are allowed lesser clearances under the NESC but must not be less than 10' horizontally from the edge of pools or diving platforms (234E1 Exception 2).
4. The swimming pool, decking, and auxiliary equipment must have a 5' minimum separation from underground cables.

234E1. Clearance of wires, conductors, cables, or unguarded rigid live parts installed over or near swimming areas with no wind displacement.

OVERHEAD
REQUIREMENTS

1. Swimming Pools

Where wires, conductors, cables, or unguarded rigid live parts are over a swimming pool or the surrounding area, the clearances in any direction shall be not less than those shown in Table 234-3 and illustrated in Figure 234-3.

EXCEPTION 1: This rule does not apply to a pool fully enclosed by a solid or screened permanent structure.

EXCEPTION 2: This rule does not apply to communication conductors and cables, effectively grounded surge-protection wires, neutral conductors meeting Rule 230E1, guys and messengers, supply cables meeting Rule 230C1, and supply cables of 0 to 750 V meeting Rule 230C2 or 230C3 when these facilities are 3m (10ft) or more horizontally from the edge of the pool, diving platform, diving tower, water slide, or other fixed, pool-related structures.

351C. Other conditions 1. Swimming pools (in-ground)

UNDERGROUND
REQUIREMENTS

Supply cable should not be installed within 1.5m (5ft) horizontally of a swimming pool or its auxiliary equipment.

2. Buildings and other structures

Cable should not be installed directly under the foundations of buildings or other structures, such as above ground swimming pools, tanks, toolsheds, etc.

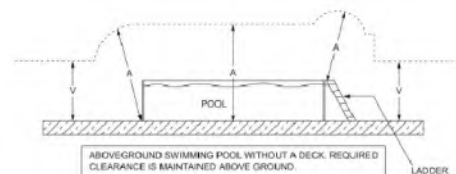
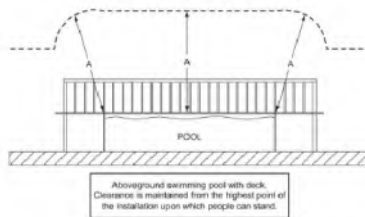
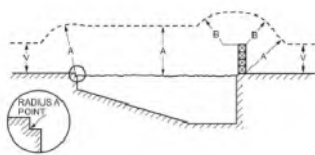

NESC Table 234-3--Clearance of wires, conductors, cables, or unguarded rigid live parts over or near swimming pools (1)

(Voltages are phase to ground for effectively grounded circuits and those other circuits where all ground faults are cleared by promptly de-energizing the faulted section, both initially and following subsequent breaker operations. See the definitions section for voltages of other systems. Clearances are with no wind displacement. See Rules 234E1, 234E2, and 234H4.)

Note: A, B, and V are shown in associated figures.	Insulated communication conductors and cables; messengers; overhead shield/surge protection wires; effectively grounded guys; ungrounded portions of guys exposed to 0 to 300 V (2) (4); neutral conductors meeting Rule 230E1; supply cables meeting Rule 230C1 (ft)	Unguarded rigid live parts, 0 to 750 V; noninsulated communication conductors; supply cables of 0 to 750 V meeting Rule 230C2 or 230C3; ungrounded portions of guys meeting Rules 215C2 and 279A1 exposed to open supply conductors of over 300 V to 750 V (1) (4) (ft)	Supply cables over 750 V meeting Rule 230C2 or 230C3; open supply conductors, 0 to 750 V (3) (ft)	Unguarded rigid live parts over 750 V to 22 kV; ungrounded portions of guys meeting Rules 215C2 and 279A1 exposed to over 750V to 22 kV (1) (4) (ft)	Open supply conductors, over 750 V to 22 kV (ft)
A. Clearance in any direction from the water level, edge of pool, base of diving platform or anchored raft	22.0	22.5	23.0	24.5	25.0
B. Clearance in any direction to the diving platform, tower, water slide, or other fixed, pool-related structures	14.0	14.5	15.0	16.5	17.0
V. Vertical clearances over adjacent land	Clearance shall be as required by Rule 232. See standard# 02 10 06				

1. The portion(s) of span guys between guy insulators and the portion(s) of anchor guys above guy insulators that are not effectively grounded shall have clearances based on the highest voltage to which they may be exposed due to a slack conductor or guy.
2. The portion of anchor guys below the lowest insulator meeting Rules 279A1 and 215C2a may have the same clearance as effectively grounded guys.
3. Does not include neutral conductors meeting Rule 230E1.
4. These clearance values also apply to guy insulators.

CONCRETE PIPE PROTECTION FOR POLES,
DOWN GUYS AND EQUIPMENT PADS.

THIS STANDARD COVERS SPECIFIC AND GENERAL REQUIREMENTS FOR THE PROTECTION OF POLES, DOWN GUYS AND EQUIPMENT PADS.

SPECIFIC DESIGNS CAN BE DEVELOPED FOR ANY INSTALLATION BY USING THE GENERAL REQUIREMENTS FOUND ON THIS STANDARD.

MATERIAL LIST

ITEM	IIN NUMB.	DESCRIPTION	QTY
1	***	6' X 7' PIPE	1
2	***	CONCRETE	.5

*** NON STOCK ITEM

* AS REQUIRED

NOTE:
WHEN UTILITY REQUIRES A CUSTOMER TO INSTALL POLE OR PAD PROTECTION, PROTECTION MUST BE INSTALLED BEFORE SERVICE IS ENERGIZED

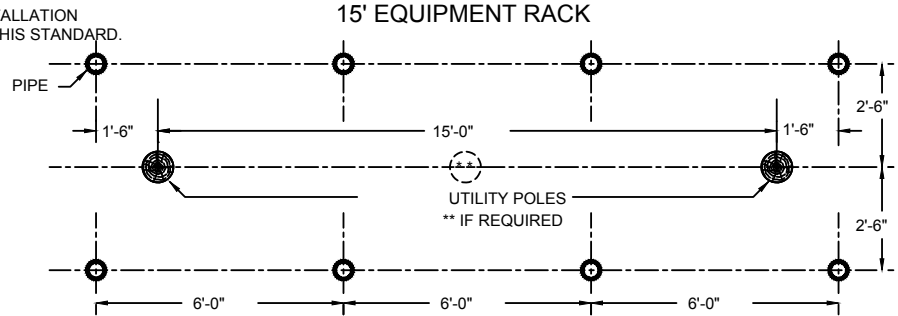

POLE AND SHORT DOWN GUY

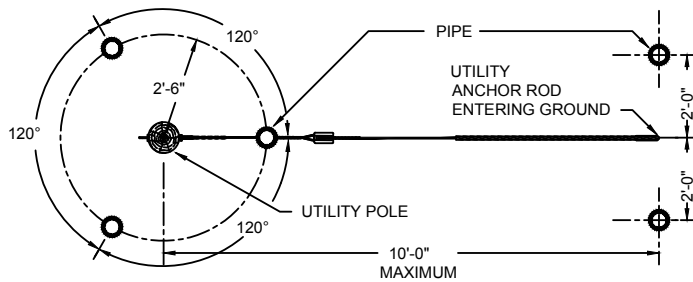

NOTE:
FOR INFORMATION REGARDING GROUNDING AND/OR INSULATING THE GUY WIRE REFER TO STANDARD 150102

GENERAL REQUIREMENTS FOR POLE AND DOWN GUY PROTECTION

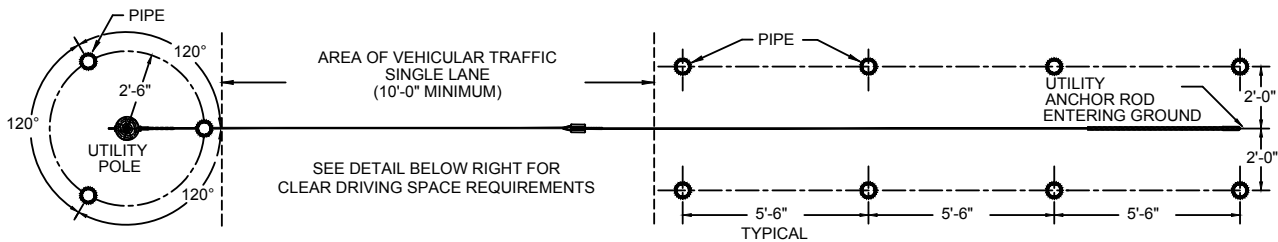

DETAIL OF PIPE INSTALLATION

6" X 7' EXTRA STRONG STEEL PIPE TO BE FILLED WITH CONCRETE AND ROUNDED OFF AT THE TOP TO SHED WATER.

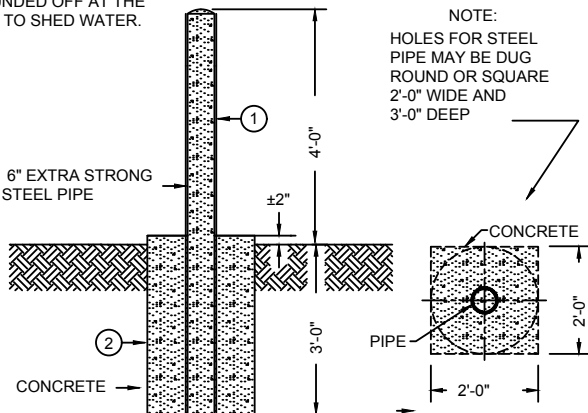

NOTE:
HOLES FOR STEEL PIPE MAY BE DUG ROUND OR SQUARE 2'-0" WIDE AND 3'-0" DEEP

CLEAR DRIVING SPACE REQUIREMENTS

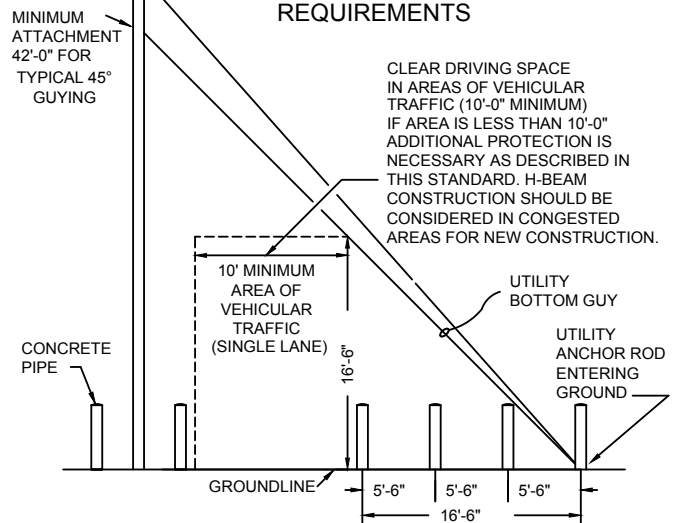

SEE DRAWING ON LOWER
LEFT CORNER OF PAGE #1
FOR DETAIL INSTALLATION
OF CONCRETE PIPE.

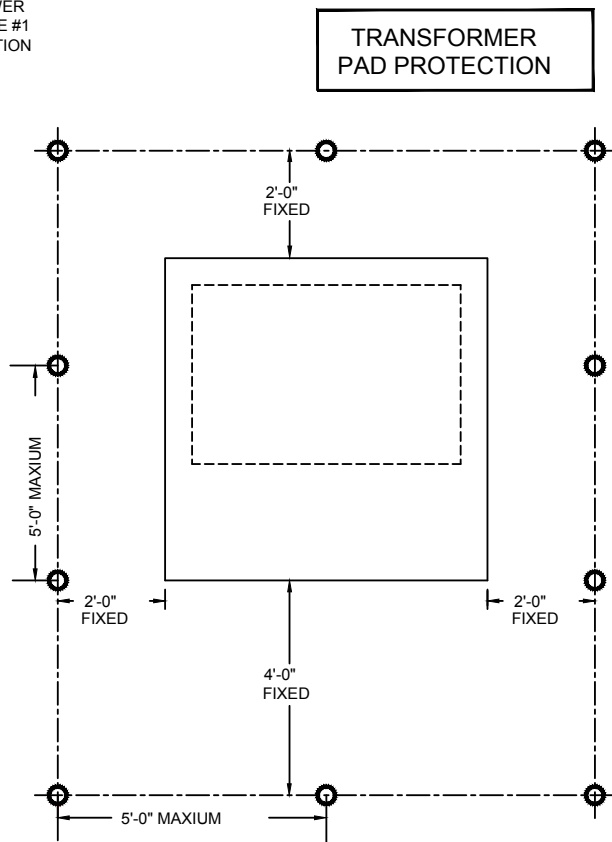

INSTALLATION OF PIPE PROTECTION TO BE INSTALLED WITH FIXED CLEARANCES AS FOLLOWS: SIZE OF PAD PLUS 2'-0" CLEARANCE IN REAR AND ON BOTH SIDES OF PAD, WITH 4'-0" CLEARANCE IN FRONT OF PAD. THIS ESTABLISHES THE AREA TO BE PROTECTED. DISTANCE BETWEEN PROTECTION POINTS WILL BE EQUALLY SPACED WITH A MAXIMUM OF 5'-0" SEPARATION.

SEE DRAWING ON LOWER
LEFT CORNER OF PAGE #1
FOR DETAIL INSTALLATION
OF CONCRETE PIPE.

**SWITCHGEAR/SWITCHGEAR AND TRANSFORMER
PROTECTION**

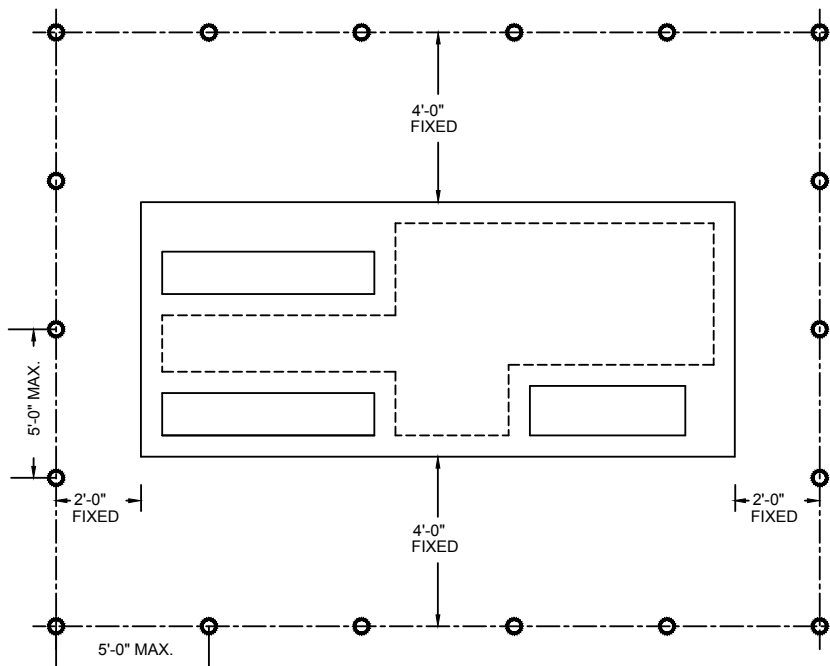

INSTALLATION OF PIPE PROTECTION TO BE INSTALLED WITH FIXED CLEARANCES AS FOLLOWS: SIZE OF PAD PLUS 4'-0" CLEARANCE BOTH FRONT AND BACK AND 2'-0" CLEARANCE ON BOTH SIDES. THIS ESTABLISHES THE AREA TO BE PROTECTED. DISTANCE BETWEEN PROTECTION POINTS WILL BE EQUALLY SPACED WITH A MAXIMUM OF 5'-0" SEPARATION.

NESC SECTION 234 AND 235 (NESC 2017)

NOTE:

1. CUSTOMER POLE HEIGHT AND LOCATION TO BE SPECIFIED BY UTILITY. 5' MINIMUM CLEARANCE REQUIRED BETWEEN CUSTOMER POLE AND MOBILE HOME AND ANY PROJECTIONS THEREFROM.
2. GROUND CLEARANCE SHOULD EXCEED NESC MINIMUMS TO THE EXTENT PRACTICAL TO ENSURE COMPLIANCE UNDER ALL LOADING CONDITIONS THROUGHOUT THE LIFE OF THE INSTALLATION. **SEE STANDARD 02 10 10** FOR NESC GROUND CLEARANCE REQUIREMENTS. SERVICE LINES NOT ENGINEERED AND SAGGED DURING INSTALLATION SHOULD NOT EXCEED 100' IN LENGTH AND MEASURED GROUND CLEARANCE SHOULD EXCEED NESC REQUIREMENTS AT ALL LOCATIONS IN THE SPAN BY A MINIMUM OF 12 INCHES.

NOTE:

CUSTOMER'S FACILITIES TO BE INSTALLED IN ACCORDANCE WITH ALL NATIONAL, STATE AND LOCAL CODES OR REGULATIONS.

ALL MATERIAL AND EQUIPMENT WITH THE EXCEPTION OF THE SERVICE DROP AND ATTACHMENT CLAMP, SERVICE ENTRANCE CONNECTIONS AND ELECTRIC METER ARE TO BE PROVIDED AND INSTALLED BY THE CUSTOMER.

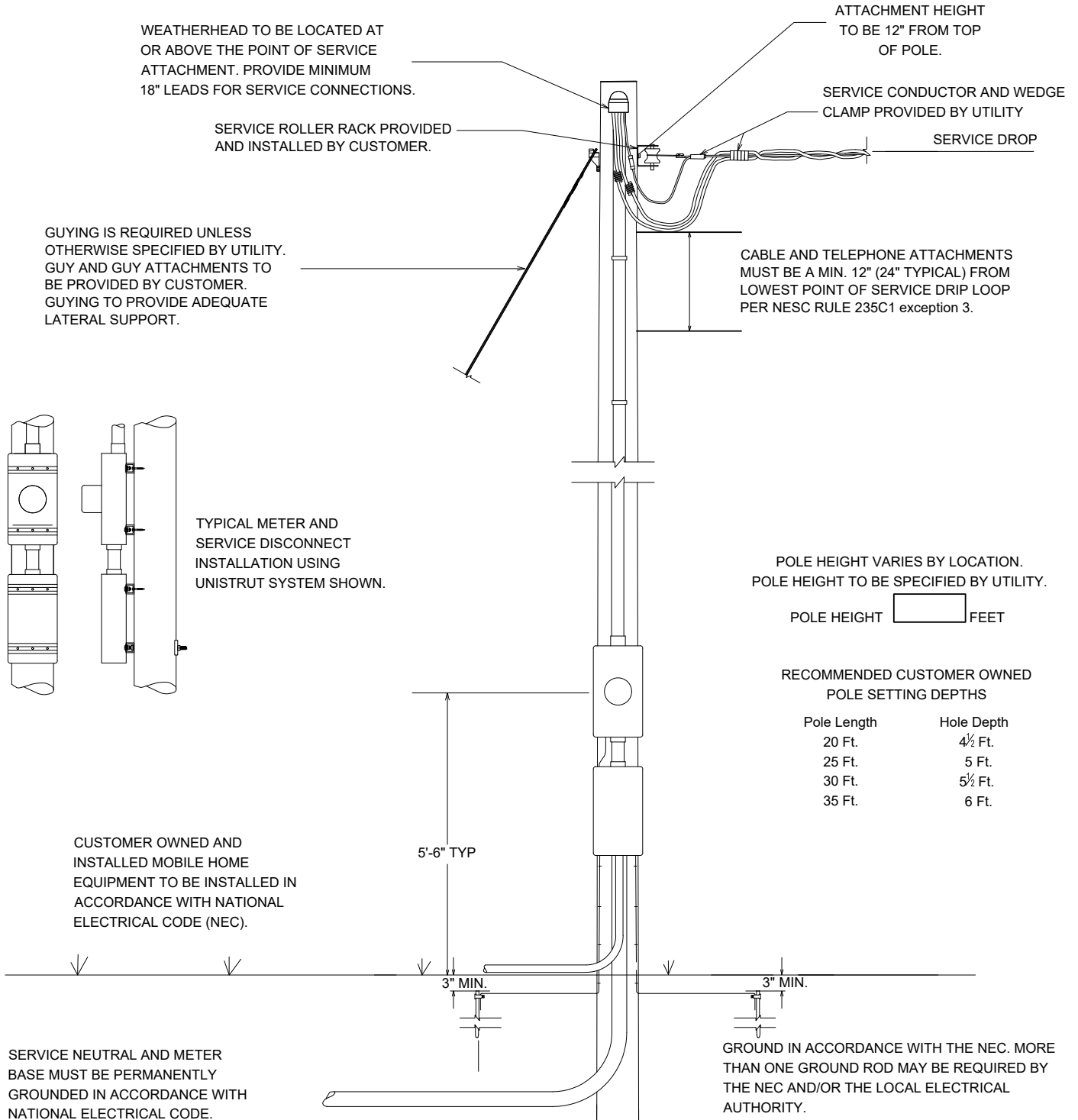

NESC SECTION 235 REQUIREMENTS (NESC 2017)

NOTE:

1. CUSTOMER POLE HEIGHT AND LOCATION TO BE SPECIFIED BY UTILITY.
2. GROUND CLEARANCE SHOULD EXCEED NESC MINIMUMS TO THE EXTENT PRACTICAL TO ENSURE COMPLIANCE UNDER ALL LOADING CONDITIONS THROUGHOUT THE LIFE OF THE INSTALLATION. **SEE STANDARD 02 10 10** FOR NESC GROUND CLEARANCE REQUIREMENTS. SERVICE LINES NOT ENGINEERED AND SAGGED DURING INSTALLATION SHOULD NOT EXCEED 100' IN LENGTH AND MEASURED GROUND CLEARANCE SHOULD EXCEED NESC REQUIREMENTS AT ALL LOCATIONS IN THE SPAN BY A MINIMUM OF 12 INCHES.

NOTE:

CUSTOMER'S FACILITIES TO BE INSTALLED IN ACCORDANCE WITH ALL NATIONAL, STATE AND LOCAL CODES OR REGULATIONS.

ALL MATERIAL AND EQUIPMENT WITH THE EXCEPTION OF THE SERVICE DROP AND ATTACHMENT CLAMP, SERVICE ENTRANCE CONNECTIONS AND ELECTRIC METER ARE TO BE PROVIDED AND INSTALLED BY THE CUSTOMER.

WEATHERHEAD TO BE LOCATED AT OR ABOVE THE POINT OF SERVICE ATTACHMENT. PROVIDE MINIMUM 18" LEADS FOR SERVICE CONNECTIONS.

ATTACHMENT HEIGHT TO BE 12" FROM TOP OF POLE.

SERVICE ROLLER RACK PROVIDED AND INSTALLED BY CUSTOMER.

CUSTOMER LOAD

SERVICE DROP UTILITY

SERVICE CONDUCTOR AND WEDGE CLAMP PROVIDED BY UTILITY

TYPICAL CUSTOMER RISER AND OVERHEAD FEED SHOWN.

CUSTOMER CONSTRUCTION AND CLEARANCES INCLUDING ALL CUSTOMER OWNED AND INSTALLED EQUIPMENT TO BE INSTALLED IN ACCORDANCE WITH NATIONAL ELECTRICAL CODE (NEC).

CABLE AND TELEPHONE ATTACHMENTS MUST BE A MIN. 12" (24" TYPICAL) FROM LOWEST POINT OF SERVICE DRIP LOOP PER NESC RULE 235C1 exception 3.

CUSTOMER PROVIDED GUYING MAY BE REQUIRED BY UTILITY.

POLE HEIGHT VARIES BY LOCATION. POLE HEIGHT TO BE SPECIFIED BY UTILITY.

POLE HEIGHT FEET

TYPICAL METER AND SERVICE DISCONNECT INSTALLATION USING UNISTRUT SYSTEM SHOWN.

RECOMMENDED CUSTOMER OWNED POLE SETTING DEPTHS

Pole Length	Hole Depth
20 Ft.	4½ Ft.
25 Ft.	5 Ft.
30 Ft.	5½ Ft.
35 Ft.	6 Ft.

SERVICE NEUTRAL AND METER BASE MUST BE PERMANENTLY GROUNDED IN ACCORDANCE WITH NATIONAL ELECTRICAL CODE.

5'-6" TYP

3" MIN.

3" MIN.

GROUND IN ACCORDANCE WITH THE NEC. MORE THAN ONE GROUND ROD MAY BE REQUIRED BY THE NEC AND/OR THE LOCAL ELECTRICAL AUTHORITY.

NOTE:

ALL MATERIALS EXCEPT THE METER ARE TO BE FURNISHED AND INSTALLED BY THE CONTRACTOR. WORK MUST CONFORM TO NATIONAL ELECTRIC CODE AND BE APPROVED BY THE AUTHORIZED INSPECTION AUTHORITY

MAXIMUM DISTANCE FROM UTILITY SUPPLY POLE - 75'. MINIMUM DISTANCE FROM UTILITY SUPPLY POLE - 15'.

THIS STANDARD DOES NOT APPLY WHEN THE UTILITY SERVICE CROSSES A STREET /HIGHWAY TO SERVE A TEMPORARY SERVICE POLE. ADDITIONAL HEIGHT WILL BE REQUIRED FOR TEMPORARY SERVICE POLE. IN SUCH CASES CONTACT YOUR SERVICE LOCATOR FOR ADDITIONAL REQUIREMENTS.

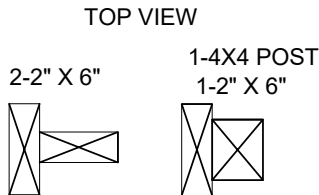
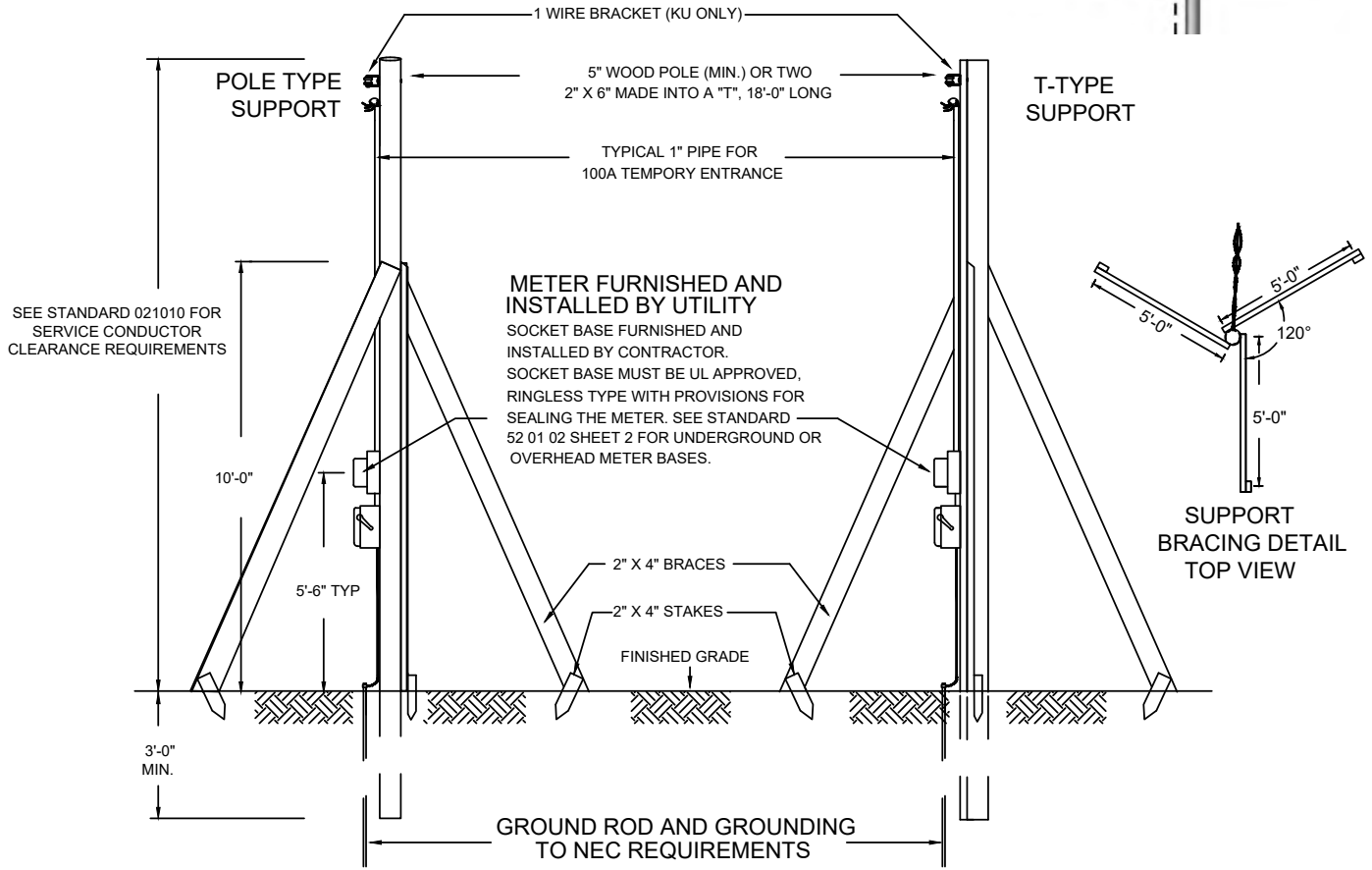
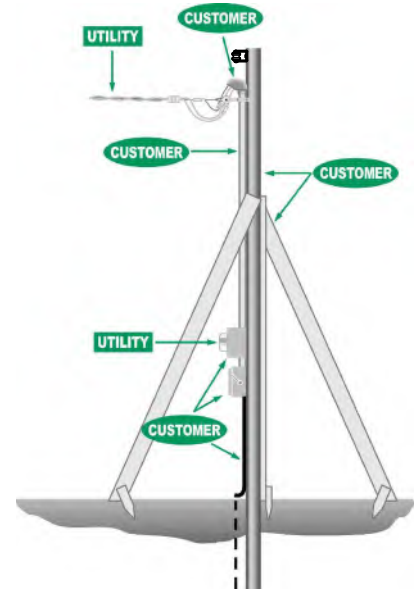

IMPORTANT
INSTALLATION AND SUPPORT DETAIL FOR OVERHEAD 1Ø 3-WIRE 120/240V 100 TEMPORARY SERVICE UP TO 200A. CONTACT YOUR SERVICE LOCATOR FOR LARGER SIZE TEMPORARIES

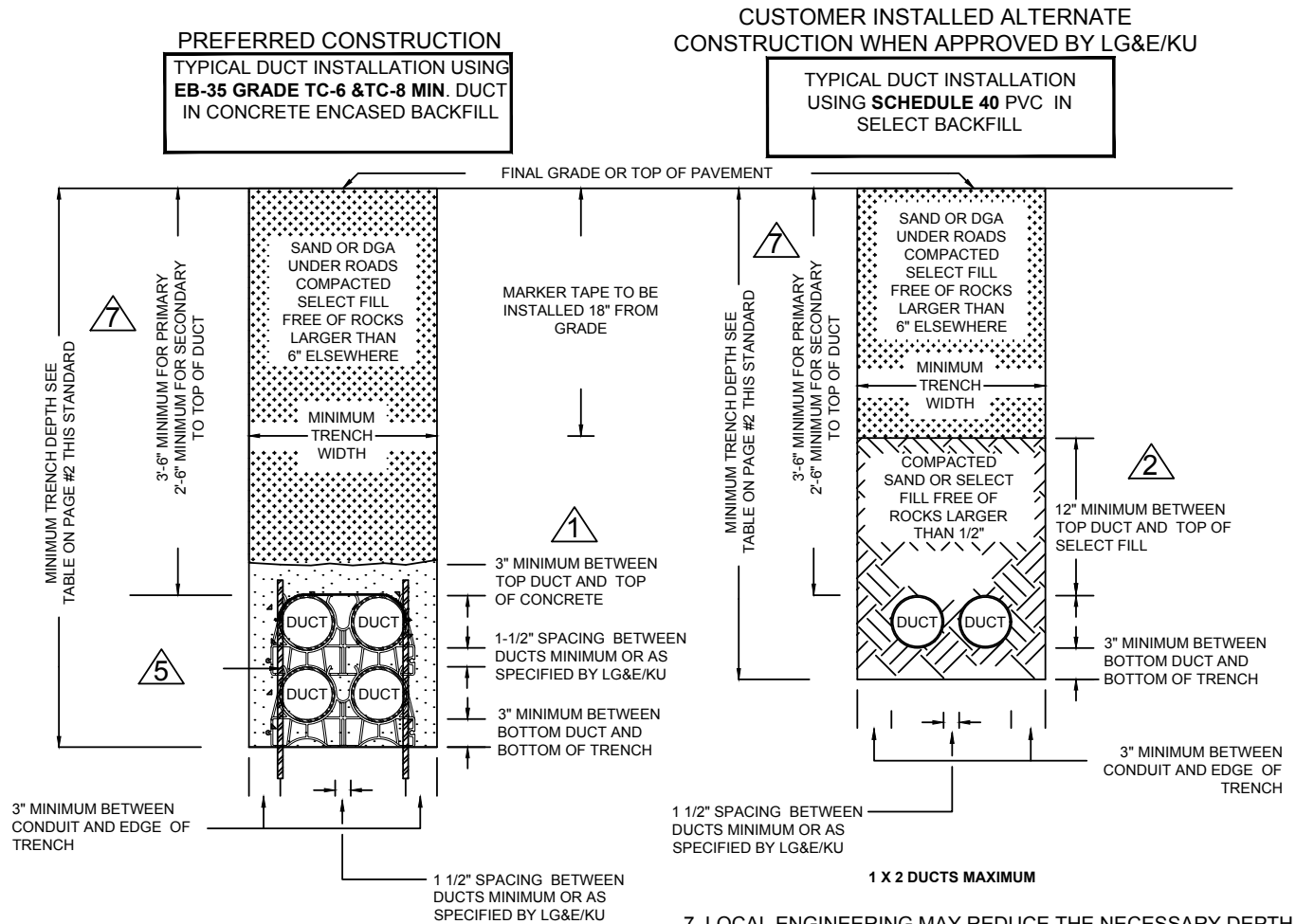

GENERAL NOTES:

1. CONCRETE ENCASED DUCT: ALL DUCT TO BE A MINIMUM NEMA EB-35 GRADE TC-6 & TC-8.
2. SELECT FILL ENCASED DUCT: ALL CUSTOMER INSTALLED DUCT IN SELECT FILL TO BE SCHEDULE 40 GRADE, NEMA TC-2 AND UL-651.
3. MINIMUM TRENCH WIDTH AND DEPTH DIMENSIONS ARE BASED ON WORST CASE PVC OUTSIDE DIMENSIONS FOR THE VARIOUS SIZE DUCTS. SEE CHARTS ON PAGE #2.
4. IF MORE THAN ONE SIZE DUCT IS USED IN A TRENCH IT WILL BE NECESSARY TO CALCULATE NEW MINIMUM WIDTH AND DEPTH DIMENSIONS. THESE DIMENSIONS WILL BE BASED ON A MINIMUM CLEARANCE OF 3" TO SIDES, TOP OR BOTTOM WITH A MINIMUM OF 1 1/2" BETWEEN DUCTS OR AS SPECIFIED BY LG&E/KU. SEE CHART ON PAGE #2 FOR TYPICAL OUTSIDE DIMENSIONS FOR DUCT.
5. DUCT IS TO BE ANCHORED PRIOR TO POURING CONCRETE. 1/2" STEEL REBAR AND TIE WIRES ARE NECESSARY IN CONCRETE FILL TO KEEP DUCTS FROM FLOATING. DUCT SPACERS, STEEL RODS AND TIES TO BE PLACED +/- 5'-0" APART. DISCONTINUOUS CONCRETE POURS ARE TO BE REINFORCED WITH 1/2" REBAR AT THEIR JUNCTION. COUPLINGS ARE REQUIRED TO BE STAGGERED 12" LONGITUDINALLY TO ENSURE CONCRETE AGGREGATE FILLS VOIDS BETWEEN CONDUITS.
6. MARKER TAPE SHOULD BE INSTALLED 18" FROM FINAL GRADE.

7. LOCAL ENGINEERING MAY REDUCE THE NECESSARY DEPTH FOR PRIMARY CIRCUITS BY UP TO 6" ON A CASE BY CASE BASIS. ADDITIONAL DEPTH WILL BE REQUIRED WHERE 48" OR GREATER RADIUS ELBOWS ARE SPECIFIED AT RISERS.
8. CONCRETE SHALL BE A MINIMUM 3500 PSI WITH A 4"-6" SLUMP AND #57 AGGREGATE. CONCRETE MAY BE REQUIRED TO BE DYED RED.

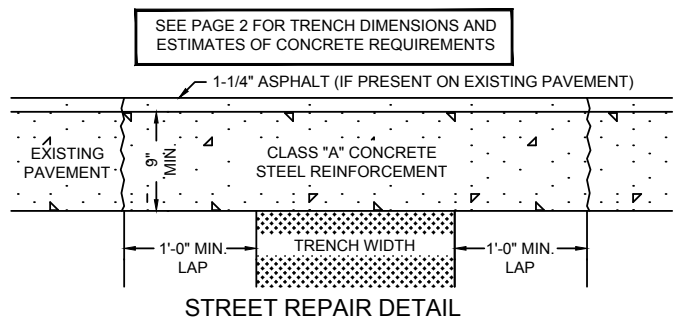

NOTES:

- DEPTH OF CONCRETE SHOULD MATCH THAT OF THE EXISTING CONCRETE IF GREATER THAN 9". SIDEWALK IS POURED BACK ONLY 4" DEEP WITH NO REINFORCEMENT.
- ALL FILL MATERIAL MUST BE THOROUGHLY COMPACTED PRIOR TO POURING CONCRETE FOR ROAD.
- BACKFILL AND RESTORATION REQUIREMENTS MAY BE MODIFIED BY PERMITTING AUTHORITY WHEN IN ROAD RIGHT OF WAY.

MINIMUM TRENCH DIMENSIONS AND CONCRETE REQUIREMENTS FOR PRIMARY DUCT BANKS
(FOR SECONDARY BANKS SUBTRACT 12" FROM THE DEPTH COLUMN)

Duct Size (")	Rows	Columns	Width (")	Depth (")	Approx. Concrete (Cu-Yds/100')
2	1	1	9	48	3.4
3			10	49	3.9
4			11	50	4.4
5			12	51	4.9
6			13	52	5.5
2	1	2	13	48	4.8
3			15	49	5.7
4			17	50	6.6
5			19	51	7.5
6			21	52	8.5
2	1	3	17	48	6.2
3			20	49	7.5
4			23	50	8.8
5			26	51	10.2
6			29	52	11.6
2	1	4	20	48	7.3
3			25	49	9.3
4			29	50	11.0
5			33	51	12.8
6			37	52	14.6
2	2	1	9	52	4.2
3			10	54	4.9
4			11	56	5.7
5			12	58	6.5
6			13	60	7.3
2	2	2	13	52	5.9
3			15	54	7.1
4			17	56	8.4
5			19	58	9.7
6			21	60	11.1
2	2	3	17	52	7.6
3			20	54	9.3
4			23	56	11.2
5			26	58	13.0
6			29	60	14.9
2	2	4	20	52	8.9
3			25	54	11.5
4			29	56	13.9
5			33	58	16.2
6			37	60	18.7
2	3	1	9	56	5.0
3			10	59	5.9
4			11	62	7.0
5			12	65	8.0
6			13	68	9.1
2	3	2	13	56	7.0
3			15	59	8.5
4			17	62	10.2
5			19	65	11.9
6			21	68	13.7
2	3	3	17	56	9.0
3			20	59	11.1
4			23	62	13.5
5			26	65	15.8
6			29	68	18.3
2	3	4	20	56	10.5
3			25	59	13.7
4			29	62	16.7
5			33	65	19.7
6			37	68	22.9
2	4	1	9	59	5.6
3			10	64	7.0
4			11	68	8.3
5			12	72	9.5
6			13	76	10.9
2	4	2	13	59	7.8
3			15	64	10.0
4			17	68	12.0
5			19	72	14.1
6			21	76	16.3
2	4	3	17	59	10.0
3			20	64	13.0
4			23	68	15.8
5			26	72	18.6
6			29	76	21.6
2	4	4	20	59	11.6
3			25	64	16.0
4			29	68	19.6
5			33	72	23.1
6			37	76	27.0

ALL ENCASED DUCT TO BE NEMA EB-35 GRADE TC-6 & TC-8
MIN.

FOR LARGER OR
NON-STANDARD
INSTALLATIONS CONTACT
STANDARDS GROUP.

DUCT SIZE & DIMENSION CHART

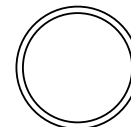

Duct Size	Outside Diameter (")
2"	2.375
3"	3.5
4"	4.5
5"	5.5625
6"	6.5625

Padmount transformers shall be located in accordance with the following guidelines with respect to exterior building walls. These guidelines are based on insurance industry recommended practices for the location of oil-filled transformers outdoors. The building owner and/or tenants fire insurance carrier or local inspection authority may have requirements that are more stringent and/or requirements that restrict the proximity of the equipment to doorways, fire exits, etc. It is the Customer's responsibility to determine the acceptability of the proposed location to those authorities.

TRANSFORMER		
TYPE	KVA RANGE	MINIMUM SEPARATION FROM BUILDING (FEET)*
1Ø	75 OR LESS	5
	100 TO 250	10
3Ø	75 TO 500	15
	750 TO 3000	25

*All measurements are made from the edge of the transformer pad closest to the building in question.

Exceptions for 1Ø transformers 75 KVA or smaller

The transformer pad may be placed between 5 and 3 feet from a building wall if:

1. The building wall is constructed of less-flammable construction materials such as metal, masonry, or concrete
2. All window openings in the first story within a horizontal distance of 10 feet of the transformer pad are closed using brick or block
3. All window openings in the first story beyond 10 feet and up to 25 feet horizontally from the transformer pad must utilize wired glass & steel sash or glass block or brick or block
4. All window openings in the second and third stories directly above the transformer must utilize wired glass & steel sash or glass block or brick or block

Exceptions for 3Ø transformers

The transformer pad may be placed closer to the building when utilizing a concrete or masonry firewall barrier with wing walls. The firewall barrier should be placed as far as possible from the building and shall not be placed closer than 5 feet from the building (measured from the building to the closest surface of the firewall barrier). The firewall barrier must satisfy the following criteria:

1. The wing walls shall be the same height as the firewall barrier and constructed from the same material. The wing walls shall extend 3 feet beyond the transformer pad.
2. Pre-existing buildings or block walls may not be used as part of the firewall enclosure. Exceptions may be granted on a case-by-case basis by LG&E and KU.
3. At multi-story buildings, a fire resistive roof shall be added to the firewall enclosure.
4. To lessen fire intensity and to confine the oil, should a leak occur
 - Install transformer on a LG&E and KU approved pad
 - Form a basin around the transformer pad, extending to the firewall enclosure walls and front-side sill, filled with rock, and sized to hold the total contents of the transformer.
 - The basin should be drained to a low isolated ground area, drywell, or other safe location.

SEE PAGES 2 AND 3 FOR CONSTRUCTION DETAILS

LG&E SERVICE AREA - ALL 3Ø TRANSFORMERS
TYPICAL WINGWALL CONSTRUCTION BY CUSTOMER FOR A PADMOUNT
TRANSFORMER WITH LESS THAN 8 SETS OF SECONDARIES.

NOTE:

1. THE DRAWINGS BELOW DETAIL THE TYPICAL CONSTRUCTION OF A FIRE WALL AROUND A PADMOUNT TRANSFORMER. THE ACTUAL STRUCTURAL DESIGN IS THE RESPONSIBILITY OF THE CUSTOMER. THESE DRAWINGS ASSUME THE FRONT OF THE TRANSFORMER FACES THE OPENING. FOR DIFFERENT CONFIGURATIONS OR FOR DETAILED INFORMATION ABOUT A SPECIFIC INSTALLATION, CONSULT THE JOB CONSTRUCTION PRINTS.
2. PAD REINFORCEMENT DESIGNED BY CUSTOMER, TO SUPPORT A TOTAL WEIGHT OF 17,000 LBS. FOR DETAILS ON PAD CONSTRUCTION, SEE STANDARD #42 06 03.
3. BEFORE INSTALLING PAD NOTIFY - DESIGN TECHNICIAN / LOCATOR FOR INSPECTION OF PAD FORMING, PLACEMENT OF DUCT ELLS, GROUND WIRE AND GROUND RODS. A MINIMUM OF 24 HOURS IS REQUIRED.
4. PROTECTIVE PIPE MAY BE REQUIRED. SEE DRAWING #04 10 04 FOR DETERMINATION OF PROTECTION TO BE MADE AFTER CURB AND DRIVING LANES ARE INSTALLED.
5. 3'- 0" MINIMUM INSIDE CLEARANCE ON ALL SIDES (MEASURED FROM EDGE OF TRANSFORMER PAD).
6. THE ELEVATION OF THE EQUIPMENT PAD SHOULD BE 1" ABOVE THE ELEVATION OF THE SILL OR 10" ABOVE GRADE.
7. DESIGN AND PLACEMENT OF WINGWALL CONSTRUCTION MUST BE APPROVED BY LG&E/KU.

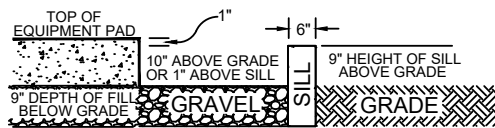

TYPICAL CONTAINMENT BASIN
TOP VIEW

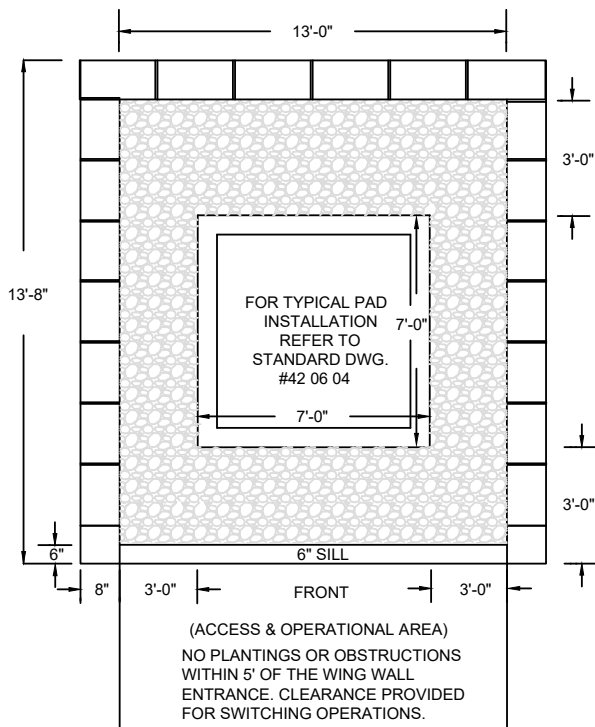

(ACCESS & OPERATIONAL AREA)
NO PLANTINGS OR OBSTRUCTIONS
WITHIN 5' OF THE WING WALL
ENTRANCE. CLEARANCE PROVIDED
FOR SWITCHING OPERATIONS.

TYPICAL
ROOF PANEL DETAIL (WHEN REQUIRED)

ALL DIMENSIONS ARE OFF EDGE OF PAD

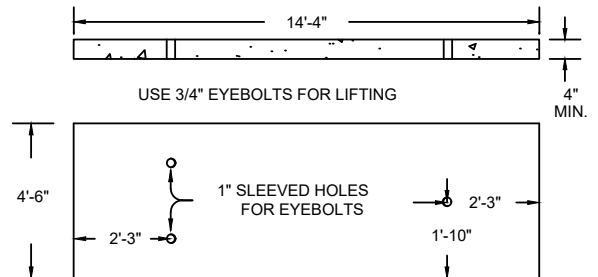

SLAB REINFORCED WITH NO.4 REBAR-12 O.C.

TOP SUPPORT COVER TO BE DESIGNED BY CUSTOMER AND BE A MIN. OF 4" THICK AND LONG ENOUGH TO COVER WINGWALLS. COVER TO BE 3 SEPARATE SECTIONS WITH 3 LIFTING LUG HOLES PER SECTION FOR EASY REMOVAL. SLABS TO BE MADE OF CONCRETE AND BE SELF SUPPORTING.

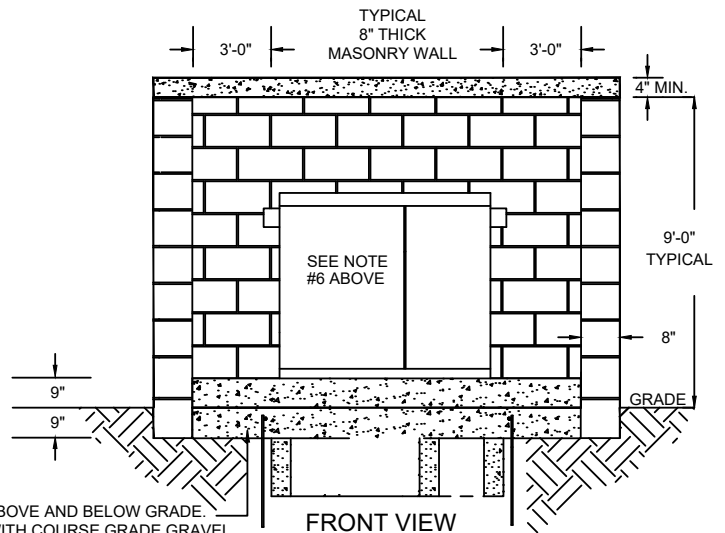

6" SILL- 9" ABOVE AND BELOW GRADE.
FILL TO SILL WITH COURSE GRADE GRAVEL.
#57 GRADE GRAVEL (DUST FREE).

KU SERVICE AREA - 3Ø 500KVA TRANSFORMERS AND SMALLER
TYPICAL WINGWALL CONSTRUCTION BY CUSTOMER FOR A PADMOUNT
TRANSFORMER WITH LESS THAN 8 SETS OF SECONDARIES.

NOTE:

1. THE DRAWINGS BELOW DETAIL THE TYPICAL CONSTRUCTION OF A FIRE WALL AROUND A PADMOUNT TRANSFORMER. THE ACTUAL STRUCTURAL DESIGN IS THE RESPONSIBILITY OF THE CUSTOMER. THESE DRAWINGS ASSUME THE FRONT OF THE TRANSFORMER FACES THE OPENING. FOR DIFFERENT CONFIGURATIONS OR FOR DETAILED INFORMATION ABOUT A SPECIFIC INSTALLATION, CONSULT THE JOB CONSTRUCTION PRINTS.
2. PAD REINFORCEMENT DESIGNED BY CUSTOMER, TO SUPPORT A TOTAL WEIGHT OF 17,000 LBS. FOR DETAILS ON PAD CONSTRUCTION, SEE STANDARD #42 06 03.
3. BEFORE INSTALLING PAD NOTIFY - DESIGN TECHNICIAN / LOCATOR FOR INSPECTION OF PAD FORMING, PLACEMENT OF DUCT ELLS, GROUND WIRE AND GROUND RODS. A MINIMUM OF 24 HOURS IS REQUIRED.
4. PROTECTIVE PIPE MAY BE REQUIRED. SEE DRAWING #04 10 04 FOR DETERMINATION OF PROTECTION TO BE MADE AFTER CURB AND DRIVING LANES ARE INSTALLED.
5. 3'-0" MINIMUM INSIDE CLEARANCE ON ALL SIDES (MEASURED FROM EDGE OF TRANSFORMER PAD).
6. THE ELEVATION OF THE EQUIPMENT PAD SHOULD BE 1" ABOVE THE ELEVATION OF THE SILL OR 10" ABOVE GRADE.
7. DESIGN AND PLACEMENT OF WINGWALL CONSTRUCTION MUST BE APPROVED BY LG&E/KU.

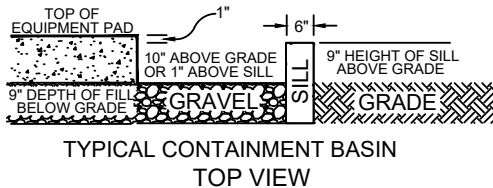

TYPICAL
ROOF PANEL DETAIL (WHEN REQUIRED)

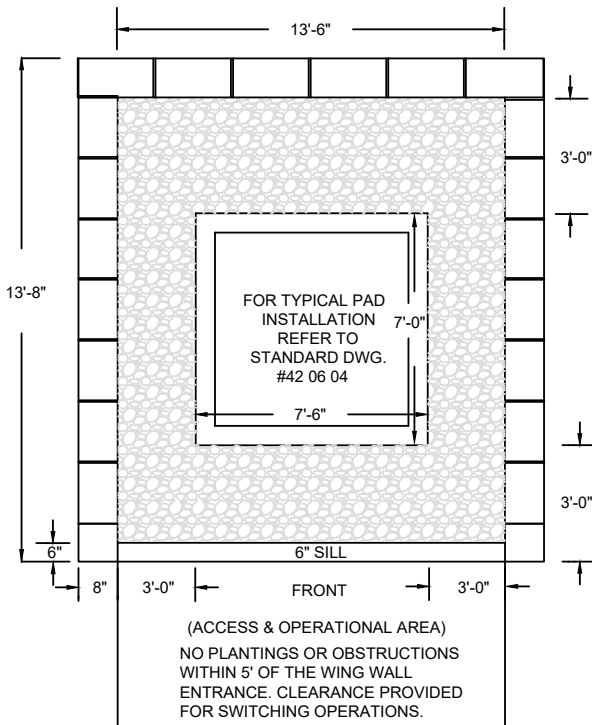
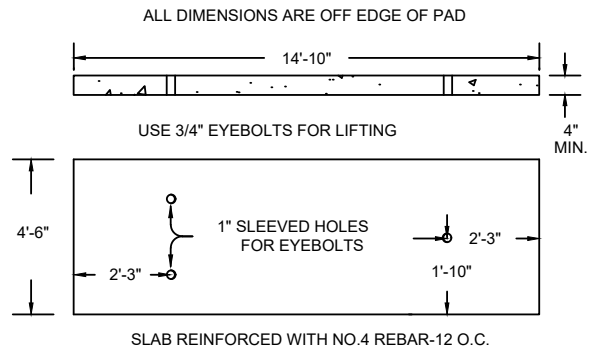

TOP SUPPORT COVER TO BE DESIGNED BY CUSTOMER AND BE A MIN. OF 4" THICK AND LONG ENOUGH TO COVER WINGWALLS. COVER TO BE 3 SEPARATE SECTIONS WITH 3 LIFTING LUG HOLES PER SECTION FOR EASY REMOVAL. SLABS TO BE MADE OF CONCRETE AND BE SELF SUPPORTING.

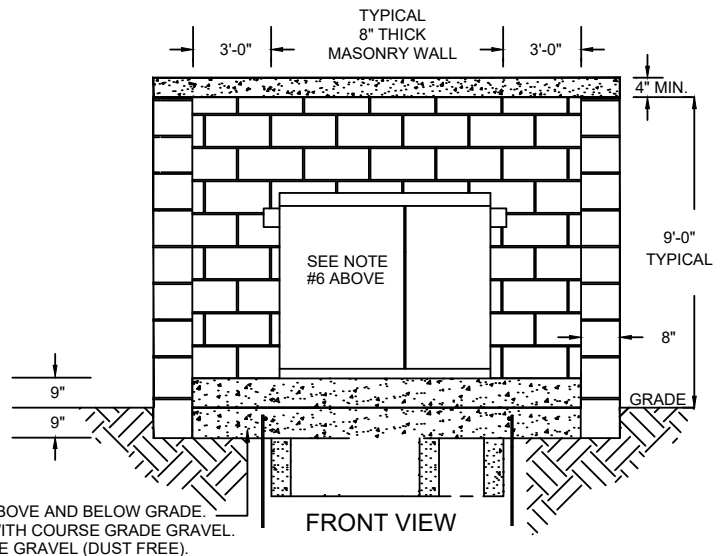

KU SERVICE AREA - 3Ø TRANSFORMERS LARGER THAN 500KVA
TYPICAL WINGWALL CONSTRUCTION BY CUSTOMER FOR A PADMOUNT
TRANSFORMER WITH LESS THAN 8 SETS OF SECONDARIES.

NOTE:

1. THE DRAWINGS BELOW DETAIL THE TYPICAL CONSTRUCTION OF A FIRE WALL AROUND A PADMOUNT TRANSFORMER. THE ACTUAL STRUCTURAL DESIGN IS THE RESPONSIBILITY OF THE CUSTOMER. THESE DRAWINGS ASSUME THE FRONT OF THE TRANSFORMER FACES THE OPENING. FOR DIFFERENT CONFIGURATIONS OR FOR DETAILED INFORMATION ABOUT A SPECIFIC INSTALLATION, CONSULT THE JOB CONSTRUCTION PRINTS.
2. PAD REINFORCEMENT DESIGNED BY CUSTOMER, TO SUPPORT A TOTAL WEIGHT OF 17,000 LBS. FOR DETAILS ON PAD CONSTRUCTION, SEE STANDARD #42 06 03.
3. BEFORE INSTALLING PAD NOTIFY - DESIGN TECHNICIAN / LOCATOR FOR INSPECTION OF PAD FORMING, PLACEMENT OF DUCT ELLS, GROUND WIRE AND GROUND RODS. A MINIMUM OF 24 HOURS IS REQUIRED.
4. PROTECTIVE PIPE MAY BE REQUIRED. SEE DRAWING #04 10 04 FOR DETERMINATION OF PROTECTION TO BE MADE AFTER CURB AND DRIVING LANES ARE INSTALLED.
5. 3'- 0" MINIMUM INSIDE CLEARANCE ON ALL SIDES (MEASURED FROM EDGE OF TRANSFORMER PAD).
6. THE ELEVATION OF THE EQUIPMENT PAD SHOULD BE 1" ABOVE THE ELEVATION OF THE SILL OR 10" ABOVE GRADE.
7. DESIGN AND PLACEMENT OF WINGWALL CONSTRUCTION MUST BE APPROVED BY LG&E/KU.

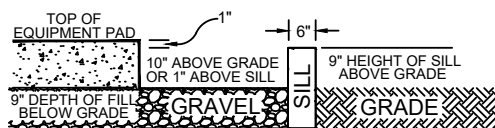

TYPICAL CONTAINMENT BASIN
TOP VIEW

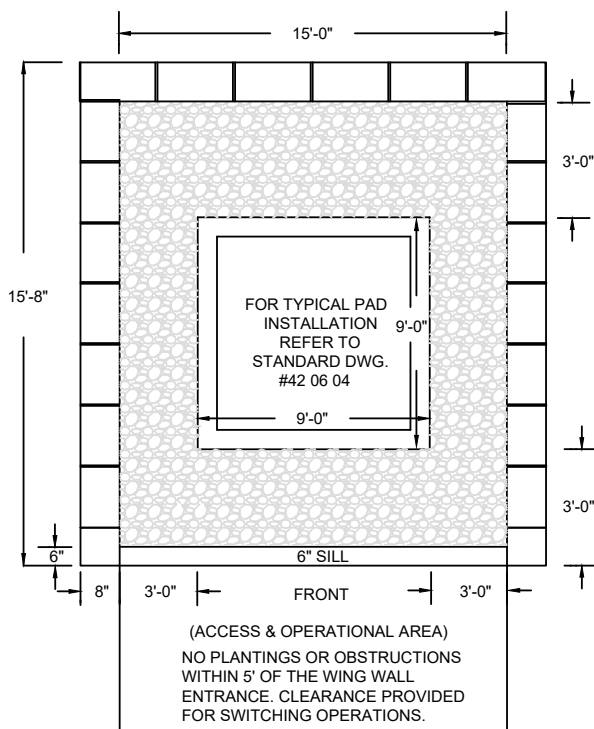

(ACCESS & OPERATIONAL AREA)
NO PLANTINGS OR OBSTRUCTIONS
WITHIN 5' OF THE WING WALL
ENTRANCE. CLEARANCE PROVIDED
FOR SWITCHING OPERATIONS.

TYPICAL
ROOF PANEL DETAIL (WHEN REQUIRED)

ALL DIMENSIONS ARE OFF EDGE OF PAD

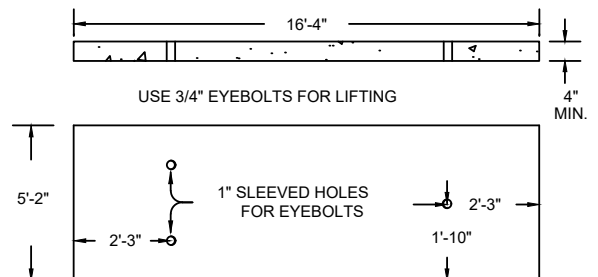

SLAB REINFORCED WITH NO.4 REBAR-12 O.C.

TOP SUPPORT COVER TO BE DESIGNED BY CUSTOMER AND BE A MIN. OF 4" THICK AND LONG ENOUGH TO COVER WINGWALLS. COVER TO BE 3 SEPARATE SECTIONS WITH 3 LIFTING LUG HOLES PER SECTION FOR EASY REMOVAL. SLABS TO BE MADE OF CONCRETE AND BE SELF SUPPORTING.

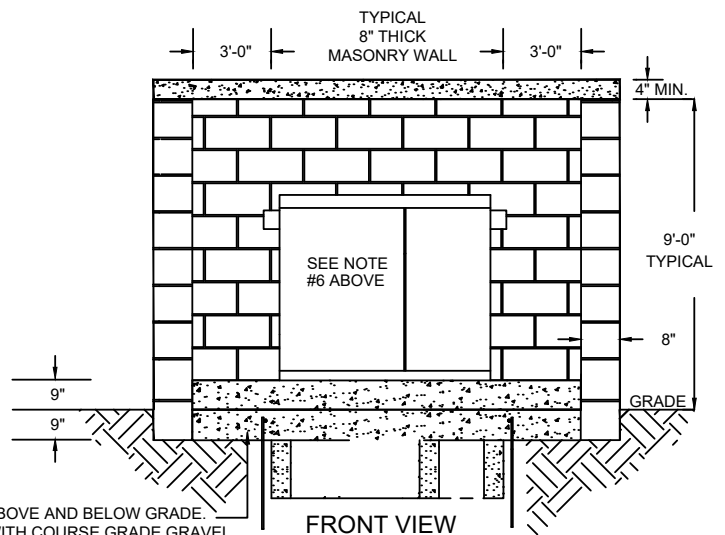

6" SILL- 9" ABOVE AND BELOW GRADE.
FILL TO SILL WITH COURSE GRADE GRAVEL.
#57 GRADE GRAVEL (DUST FREE).

TYPICAL WINGWALL CONSTRUCTION BY CUSTOMER FOR A PADMOUNT TRANSFORMER WITH MORE THAN 8 SETS OF SECONDARIES.

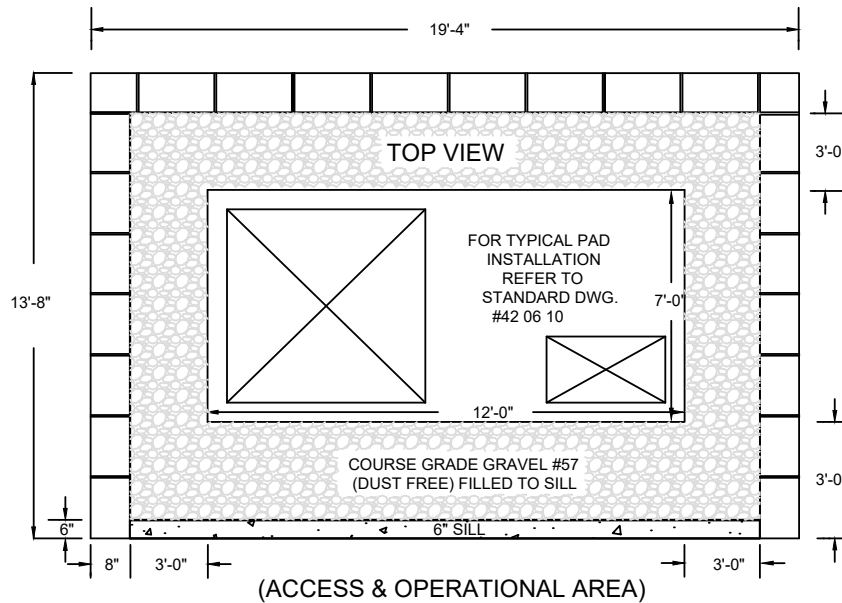

NO PLANTINGS OR OBSTRUCTIONS WITHIN 5' OF THE WING WALL ENTRANCE. CLEARANCE PROVIDED FOR SWITCHING OPERATIONS.

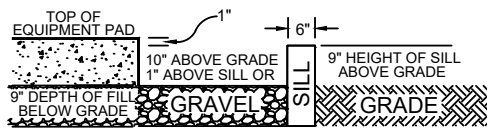

TYPICAL CONTAINMENT BASIN

TOP SUPPORT COVER TO BE DESIGNED BY CUSTOMER AND BE LONG ENOUGH TO COVER WINGWALLS. COVER TO BE 3 SEPERATE SECTIONS WITH 3 LIFTING LUG HOLES PER SECTION FOR EASY REMOVAL. SLABS TO BE MADE OF CONCRETE AND BE SELF SUPPORTING. COMPOSITION AND STRENGTH TO BE DETERMINED BY OWNER'S ENGINEER OR ARCHITECT.

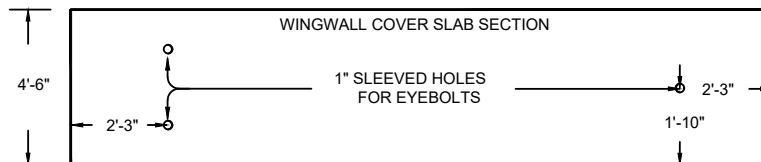

TYPICAL ROOF PANEL DETAIL (WHEN REQUIRED)

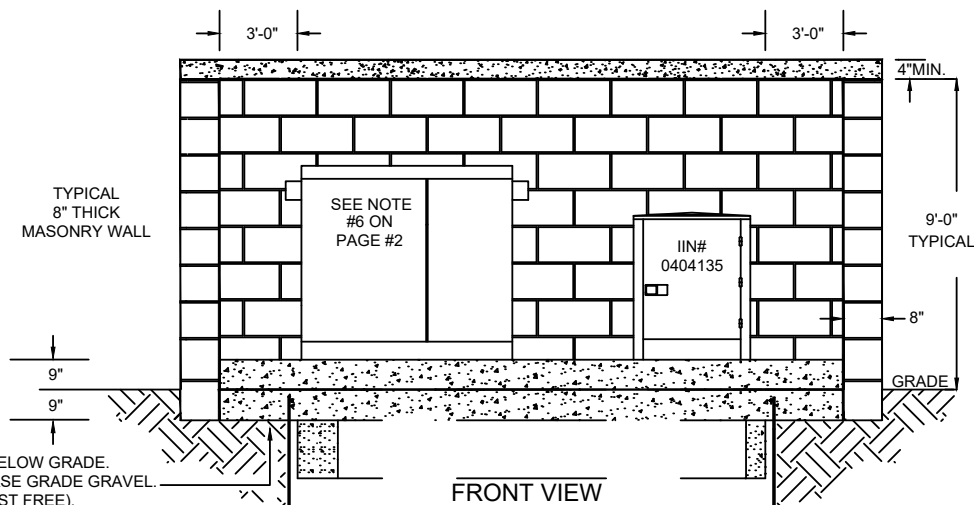

NOTE:

- PAD REINFORCEMENT DESIGNED BY CUSTOMER, TO SUPPORT A TOTAL WEIGHT OF 2,500 LBS.
- BEFORE INSTALLING PAD NOTIFY LG&E/KU FOR INSPECTION OF SITE, AND PLACEMENT OF DUCT ELLS, GROUND WIRE AND GROUND RODS. A MINIMUM OF ONE WORKING DAY NOTICE IS REQUIRED. LG&E SERVICE AREAS MUST USE A PRECAST PAD, A POURED PAD IS NOT ACCEPTABLE.
- DIRECTION OF DUCT DETERMINED BY LAYOUT FOR CUSTOMER INSTALLED PAD.
- PROTECTIVE PIPE MAY BE REQUIRED. SEE STANDARD 04 10 04
- DUCT SIZE AND DIRECTION TO BE SPECIFIED BY UTILITY

PRECAST CONCRETE PAD

IN	DESCRIPTION	STYLE
3007597	PAD, SWITCHGEAR, CONCRETE	6, 9, 10, 11, AND 12

CALL FOR INSPECTION
(ONE DAY PRIOR TO POUR OR
AFTER PRECAST INSTALLATION)

NAME: _____

PHONE: _____

TURNED UP POSITION OF
DUCTS TO BE PLACED ON A
3'-1" SQUARE PATTERN,
CENTERED IN PAD OPENING.

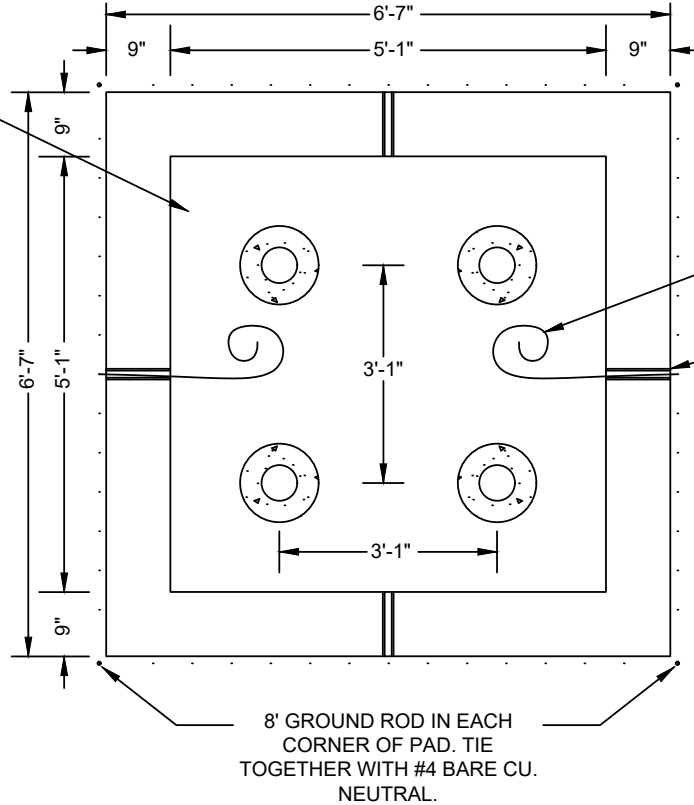

#4 BARE CU.
GROUND WIRE

1" PVC SLEEVE FOR
GROUND WIRE
QTY. 4

CLEARANCES:
10' FRONT AND REAR AND 3'
ON SIDES TO ANY
OBSTRUCTION OR
PLANTING.

8" GROUND ROD IN EACH
CORNER OF PAD. TIE
TOGETHER WITH #4 BARE CU.
NEUTRAL.

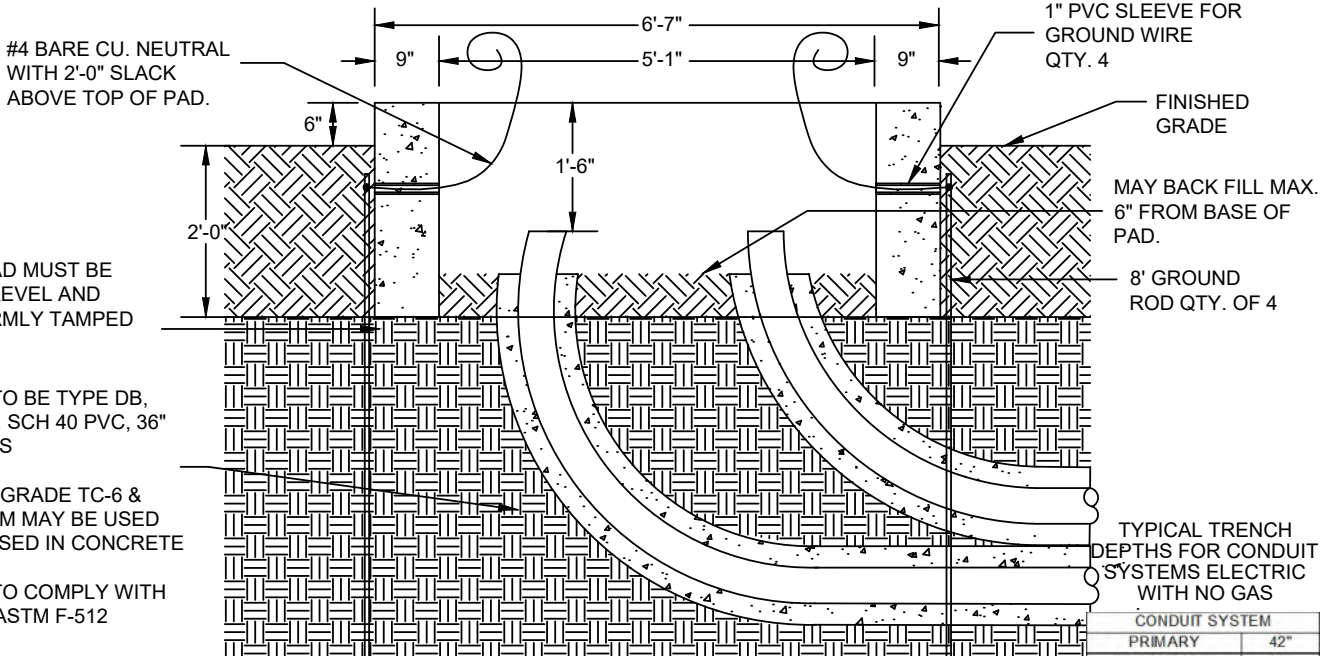

PRECAST PAD MUST BE
INSTALLED LEVEL AND
REST ON FIRMLY TAMPED
BACKFILL.

DUCT ELLS TO BE TYPE DB,
GRADE TC-2, SCH 40 PVC, 36"
LONG RADIUS

TYPE EB-35, GRADE TC-6 &
TC-8 MINIMUM MAY BE USED
WHEN ENCASED IN CONCRETE

DUCT ELLS TO COMPLY WITH
UL-651 AND ASTM F-512

TYPICAL TRENCH
DEPTHS FOR CONDUIT
SYSTEMS ELECTRIC
WITH NO GAS

CONDUIT SYSTEM	
PRIMARY	42"
SECONDARY	30"
STREET LIGHTING	24"



NOTE:

1. SEE STANDARD 42 06 26 FOR FIBERGLASS BOX PAD INSTALLATION DETAILS.
2. SEE STANDARD 42 06 22 FOR POURED AND PRECAST CONCRETE PAD INSTALLATION DETAILS.

TYPICAL DEADFRONT SWITCHGEAR PADS

IIN	DESCRIPTION	STYLE
3003549	PAD, SWITCHGEAR, FIBERGLASS	5
3003550	PAD, SWITCHGEAR, FIBERGLASS	6, 9, 10, 11, AND 12
3007597	PAD, SWITCHGEAR, CONCRETE	6, 9, 10, 11, AND 12

IIN# 3007597 - PRECAST CONCRETE PAD

69" x 69" x 30" DEADFRONT SWITCHGEAR PRECAST CONCRETE PAD WITH 61" x 61" OPENING.

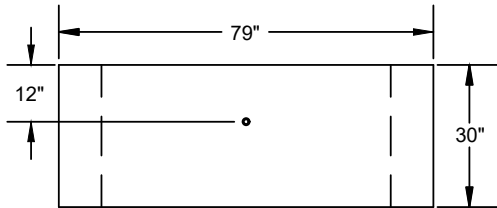

SIDE VIEW

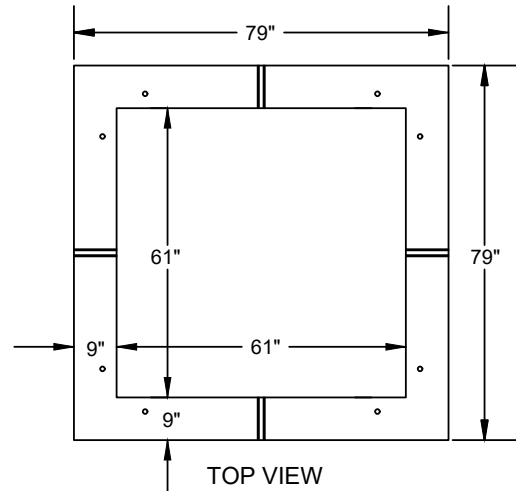

TOP VIEW

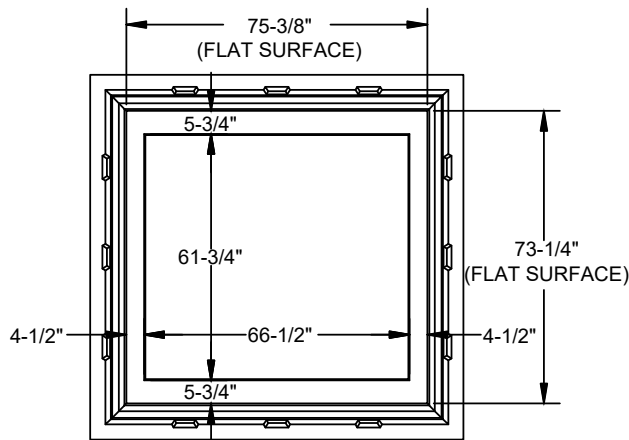

TOP VIEW

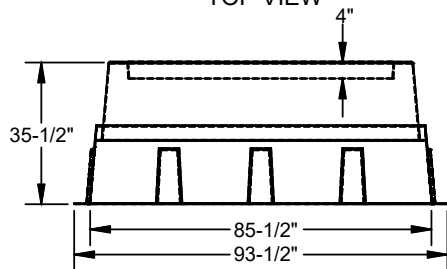

DOOR SIDE VIEW

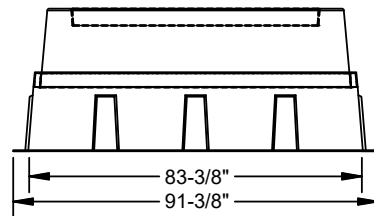

CABINET VIEW

IIN# 3003550 - FIBERGLASS PAD

75-3/8" x 73-1/4" x 35-1/2" DEADFRONT SWITCHGEAR FIBERGLASS PAD WITH 61-3/4" x 66-1/2" OPENING.

IIN# 3003549 - FIBERGLASS PAD

74" x 44-1/2" x 36" DEADFRONT SWITCHGEAR
FIBERGLASS PAD WITH 61" x 31-1/2" OPENING.

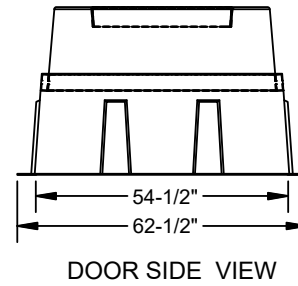
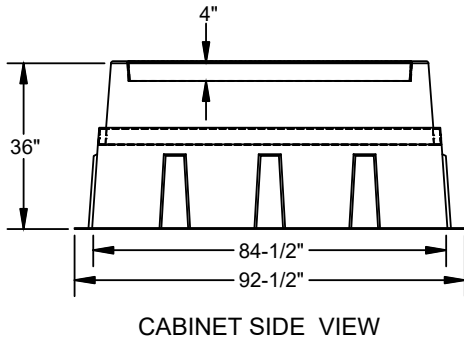
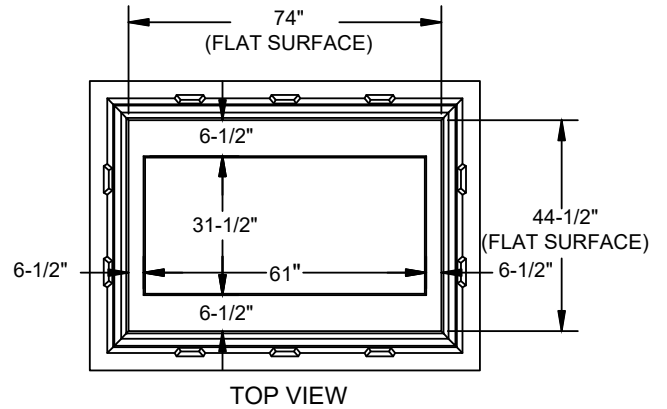

DEAD-FRONT DESIGN			
LG&E AND KU ITEM#	SWITCH BAY	FUSE BAY	DESCRIPTION
3003548	1	1	PADMOUNT, DEADFRONT STYLE #5, MANUAL, 15KV 600 AMP, 3 PHASE, 2 COMP, 1-600A GANG SWITCH AND 1-200A FUSED WITH SMU20 HOLDERS, 12" BASE EXT
7010725	2	1	PADMOUNT, DEADFRONT STYLE #6, MANUAL, 15KV 600 AMP, 3 PHASE, 4 COMP, 2-600A GANG SWITCH AND 1-200A FUSED WITH SMU20 HOLDERS, 12" BASE EXT
7010014	2	2	PADMOUNTED, DEADFRONT STLYE #9, MANUAL, 15KV 600 AMP, 3 PHASE, 4 COMP, 2-600A GANG SWITCH AND 2-200A FUSED WITH SMU20 HOLDERS, 12" BASE EXT
3007336	4	0	PADMOUNT, DEADFRONT STYLE #10, MANUAL, 15KV, 600A, 3PH, 4 COMP, 4-600A GANG SWITCH, 12" BASE TEXT
3007337	3	1	PADMOUNT, DEADFRONT STYLE #11, MANUAL, 15KV, 600A, 3PH, 4 COMP, 3-600A GANG SWITCH AND 1-200A FUSED WITH SMU20 HOLDERS, 12" BASE EXT
3007338	1	3	PADMOUNT, DEADFRONT STYLE #12, MANUAL, 15KV, 600A, 3PH, 4 COMP, 1-600A GANG SWITCH AND 3-200A FUSED WITH SMU20 HOLDERS, 12" BASE TEXT

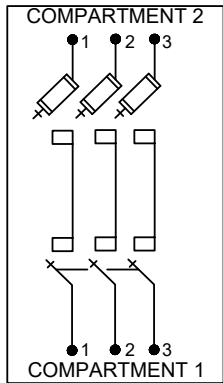

STYLE-5

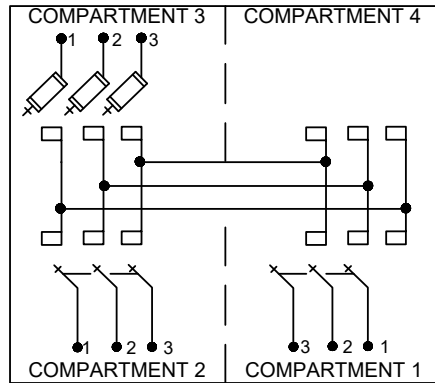

STYLE-6

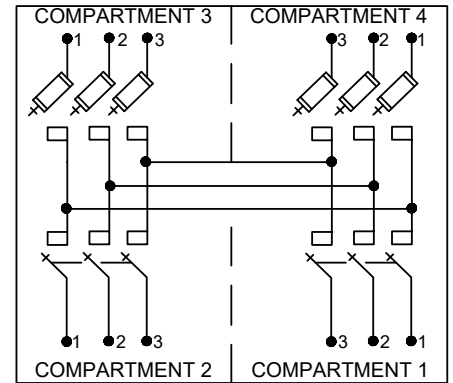

STYLE-9

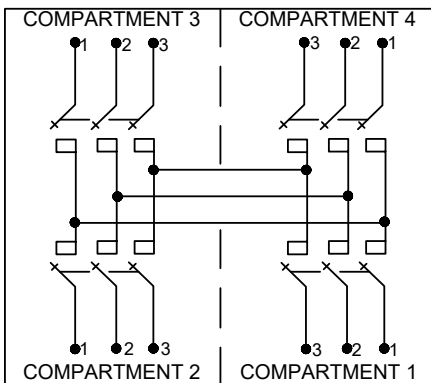

STYLE-10

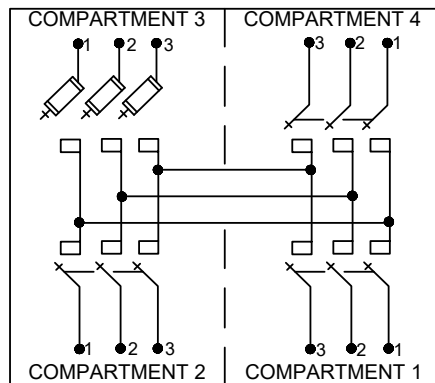

STYLE-11

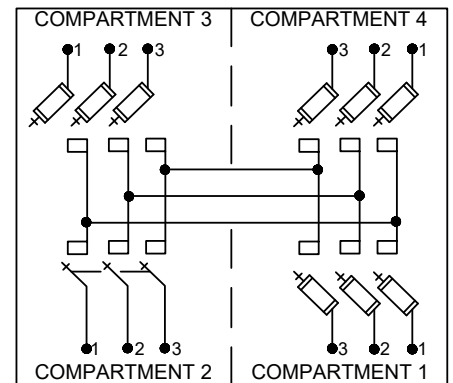

STYLE-12

Location/Address		Contact Phone #	Overhead Job Necessary <input type="checkbox"/> Yes <input type="checkbox"/> No	
Service Size _____ A	Classification	Pole-Splice Box Duct	Box Size	Secondary Voltage
	<input type="checkbox"/> <400 Amp	1 - 3" Duct (Minimum)	12" X 20" X 12"	<input type="checkbox"/> 120/240V - 1Ø - 3W
	<input type="checkbox"/> 400 Amp	1 - 3" Duct (Minimum)	13" X 24" X 15"	<input type="checkbox"/> 240/480V - 1Ø - 3W
	<input type="checkbox"/> Special	_____	_____	
Approved Splice Box Vendor/Catalog Number Information				
General: Splice boxes to be high density polyethylene supplied with non-metallic cover, captive stainless steel Penta-Head bolts and electric logo.				
12" X 20" X 12" Splice Box (IIN 1243827) Recommended for less than 400 Amp service		13" X 24" X 15" Splice Box (IIN 7003714) Recommended for 400 Amp service		
Pencell Plastics	PE1118HDH005P3	Pencell Plastics	DT132415HDX005P3	
Nordic	PHH2-16196812-MG	Nordic	PHH2-152315-MG	
Old Castle	12201010	Old Castle	13241011	

Notice: It is the responsibility of the contractor to ensure the installation is built according to the latest revision of this document. The contractor should request a current version of this document from LG&E representative before beginning construction.

Notes: Customer is responsible for the installation of the splice box and conduit system from the pole designated by LG&E to the service entrance. The customer is also responsible for the service cable from the splice box to the service entrance. LG&E will take ownership of the splice box and conduit between the pole and the splice box. All other facilities will remain the responsibility of the customer. The splice box and conduit to the designated pole must be installed to the specifications, dimensions, location and orientation specified by LG&E and this standard. For any questions concerning this information, contact your service representative. All material as well as installation of material must be approved by LG&E prior to LG&E energizing service. If splice box must be installed in a sidewalk or in or near a driving area, customer must provide a suitable traffic rated box. Consult your service representative.

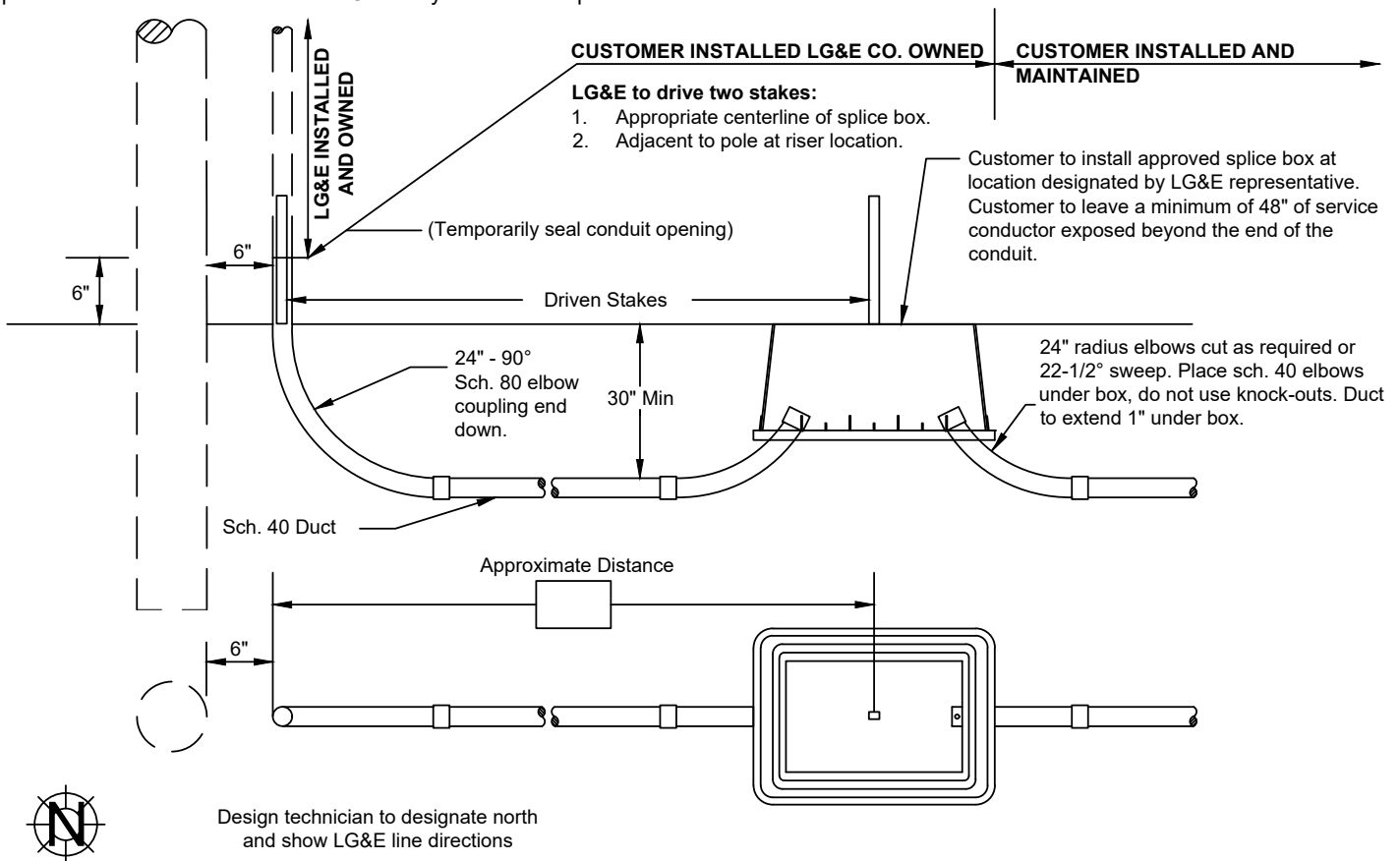

Ducts to be centered on pole with 6" between face of pole and edge of conduit and 3" face to face between multiple conduits.

*For special designs above 400A, 1Ø, contact your Design Technician.

*Always Call 811 before digging.

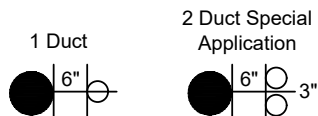

Location/Address		Contact Phone #	Overhead Job Necessary <input type="checkbox"/> Yes <input type="checkbox"/> No	
Service Size _____ A	Classification	Pole-Splice Box Duct	Box Size	Secondary Voltage
	<input type="checkbox"/> ≤ 400 Amp	1 - 5" Duct	24" X 36" X 24"	<input type="checkbox"/> 120/208V - 3Ø - 4W
	<input type="checkbox"/> 401/800 Amp	2 - 5" Ducts	24" X 36" X 24"	<input type="checkbox"/> 240V - 3Ø - 3W
	<input type="checkbox"/> Special	3 to 4 - 5" Ducts	36" X 60" X 24"	<input type="checkbox"/> 480V - 3Ø - 3W
Approved Splice Box Vendor/Catalog Number Information				
General: Splice boxes to be high density polyethylene supplied with non-metallic cover, captive stainless steel Penta-Head bolts and electric logo. *Use 24" X 36" X 24" for 2 conduits max. Use 36" X 60" X 24" for 3 or 4 conduits.				
24" X 36" X 24" Splice Box (1191901)			36" X 60" X 24" Splice Box (0939227)	
Pencell Plastics	PM243624HDX005P3	Pencell Plastics	PM366024HDX005P3	
Oldcastle	24361268	Oldcastle	36601002	

Notice: It is the responsibility of the contractor to ensure the installation is built according to the latest revision of this document. The contractor should request a current version of this document from LG&E's representative before beginning construction.

Notes: Customer is responsible for the installation of the splice box and conduit system from the pole designated by LG&E to the service entrance. The customer is also responsible for the service cable from the splice box to the service entrance. LG&E will take ownership of the splice box and conduit between the pole and the splice box. All other facilities will remain the responsibility of the customer. The splice box and conduit to the designated pole must be installed to the specifications, dimensions, location and orientation specified by LG&E and this standard. For any questions concerning this information, contact your service representative. All material as well as installation of material must be approved by LG&E prior to LG&E energizing service. If splice box must be installed in a sidewalk or in or near a driving area, customer must provide a suitable traffic rated box. Consult your service representative. If pole is located near traffic, installation of hub-band may be required.

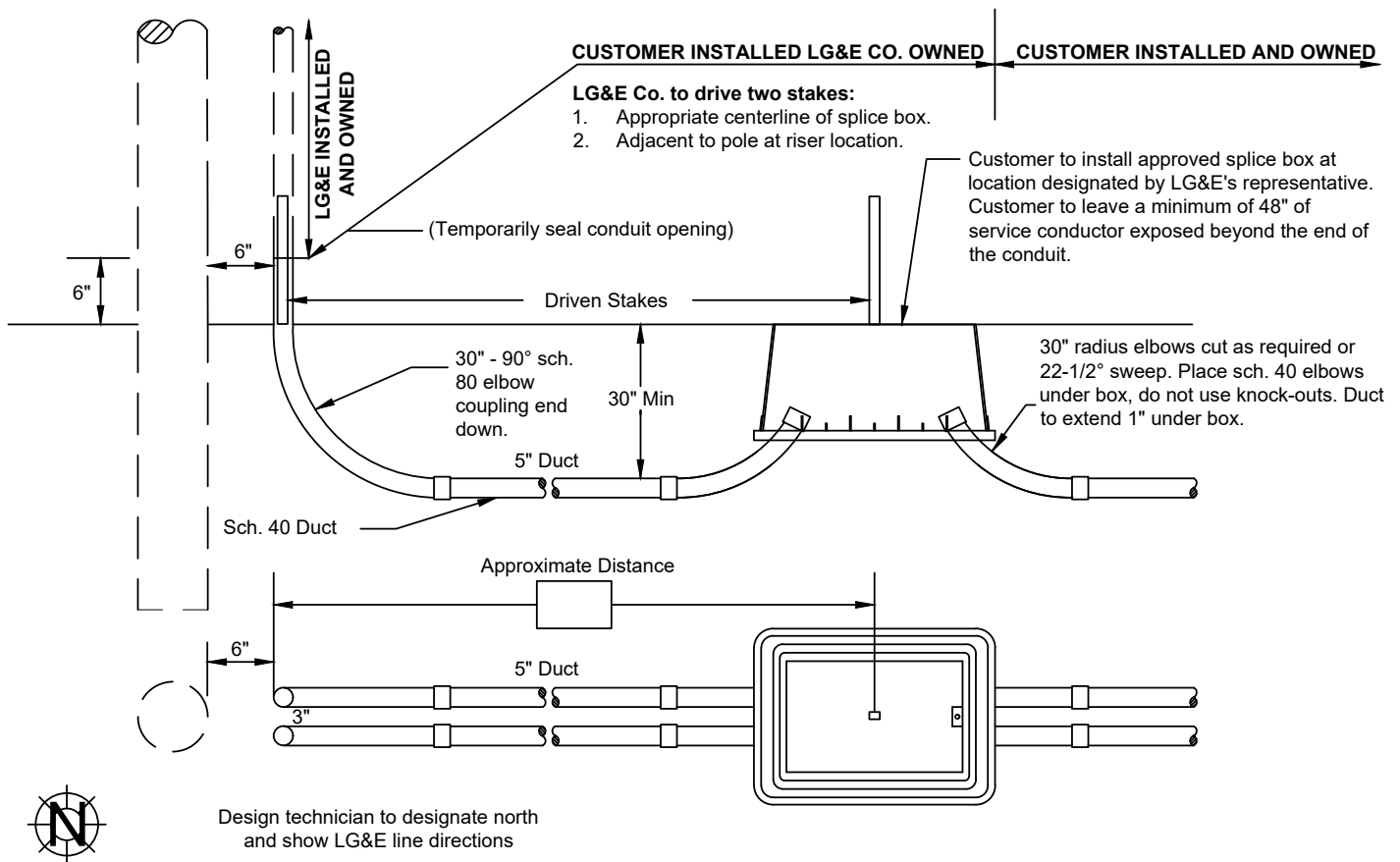

Ducts to be centered on pole with 6" between face of pole and edge of conduit and 3" face to face between multiple conduits.

*Services above 800A may be permitted where space is not available to install a padmount transformer.

*Always Call Before You Dig (BUD) 1-800-752-6007 to locate underground utilities (Kentucky Underground)

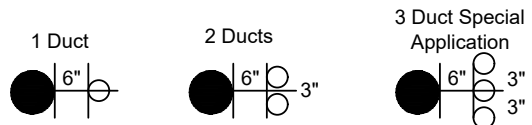

1 PHASE PARALLEL SECONDARY

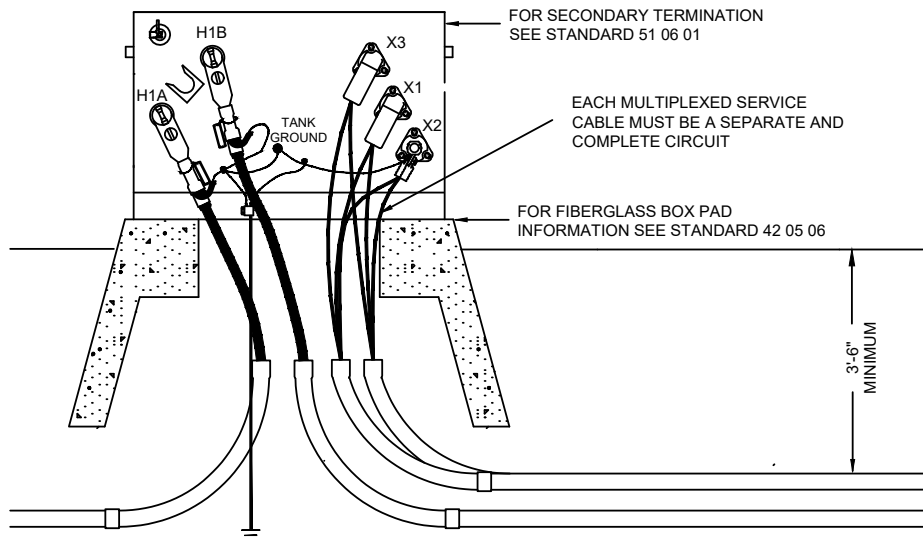

3 PHASE PARALLEL SECONDARY

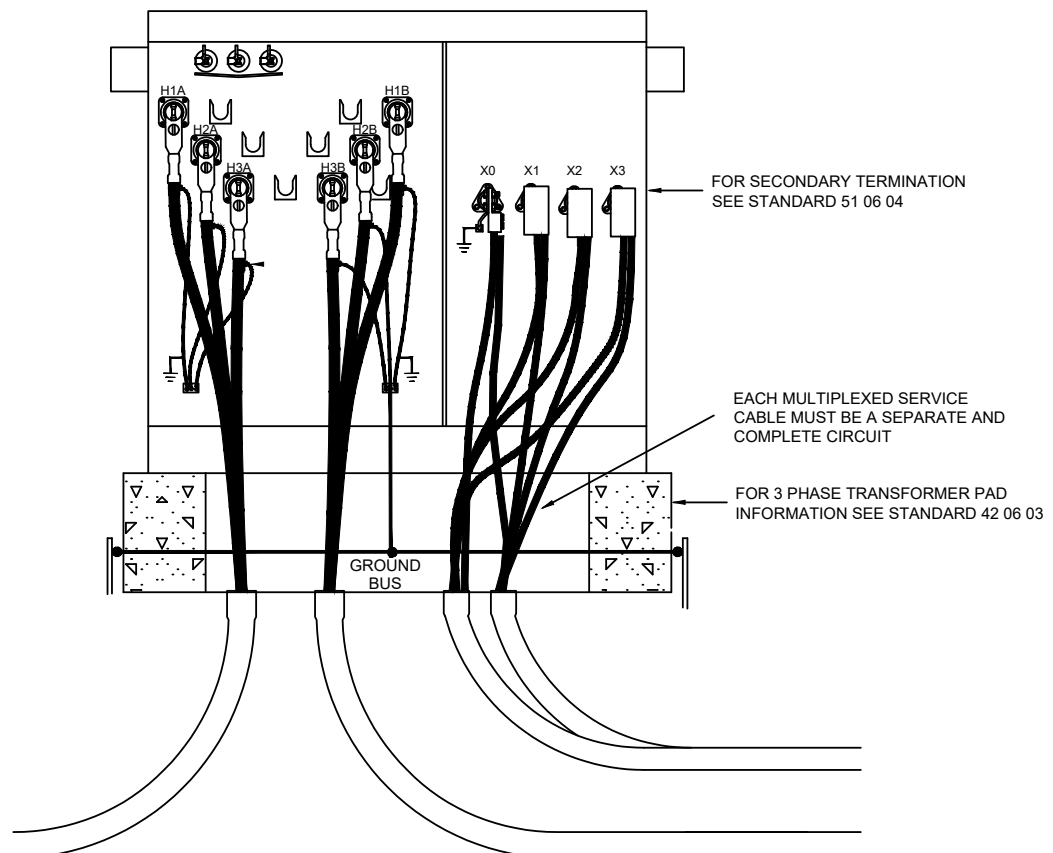

IMPORTANT NOTICE TO ELECTRICIANS / BUILDERS

UNDERGROUND SERVICES SHOULD BE LOCATED ON THE CUSTOMER'S PROPERTY AND ONLY BE BROUGHT TO UTILITY EQUIPMENT LOCATED ON THE CUSTOMER'S PROPERTY OR LOCATED ON A COMMON PROPERTY LINE SHARED WITH ADJACENT PROPERTY. SERVICES CAN NOT CROSS ADJACENT PROPERTY TO REACH UTILITY EQUIPMENT NOT LOCATED ON A COMMON PROPERTY LINE.

ALL UNDERGROUND SERVED RESIDENTIAL LOTS WILL HAVE EITHER A TRANSFORMER OR A SERVICE SPLICE BOX LOCATED ADJACENT TO ONE OF THE PROPERTY LINES. IN RARE CASES, A LOT MAY HAVE BOTH A TRANSFORMER AND A SPLICE BOX LOCATED ALONG PROPERTY LINES.

WHENEVER A TRANSFORMER IS LOCATED ALONG EITHER PROPERTY LINE, LOCATE THE METER ON THE TRANSFORMER SIDE OF THE HOUSE ON THE CLOSEST CORNER AND RUN SERVICE CONDUCTORS TO WITHIN 18" OF THE SECONDARY SIDE OF THE TRANSFORMER (SEE DETAIL).

IF **BOTH** A TRANSFORMER AND SPLICE BOX ARE PRESENT, LOCATE THE METER ON THE TRANSFORMER SIDE OF THE HOUSE ON THE CLOSEST CORNER AND RUN SERVICE CONDUCTORS TO WITHIN 18" OF THE SECONDARY SIDE OF THE TRANSFORMER (SEE DETAIL).

IF **ONLY** A SPLICE BOX IS PRESENT, LOCATE THE METER ON THE SPLICE BOX SIDE OF THE HOUSE ON THE CLOSEST CORNER AND RUN THE SERVICE CONDUCTORS TO WITHIN 18" OF THE SPLICE BOX.

IF THERE IS NEITHER A TRANSFORMER NOR A SPLICE BOX, CALL THE APPROPRIATE SERVICE LOCATOR

CLEAR WORKING ZONE AROUND UTILITY EQUIPMENT

THE CLEAR WORKING ZONE DESIGNATES AN AREA AROUND UTILITY EQUIPMENT THAT MUST REMAIN FREE OF ALL OBSTRUCTIONS, INCLUDING ANY STRUCTURES, LANDSCAPING, FENCING, ETC. THIS SPACE IS NECESSARY SO THAT UTILITY PERSONNEL CAN WORK SAFELY AROUND ENERGIZED UTILITY EQUIPMENT.

TRANSFORMERS ONLY

UTILITY WORK ZONE AREA IS DEFINED AS 10'-0" CLEARANCE IN FRONT OF THE DOOR 3'-0" AWAY FROM OTHER SIDES OF THE TRANSFORMER

ELECTRIC PEDESTAL OR SPLICE BOX

UTILITY WORK ZONE AREA IS DEFINED AS 3'-0" AROUND PEDESTAL AND SPLICE BOXES

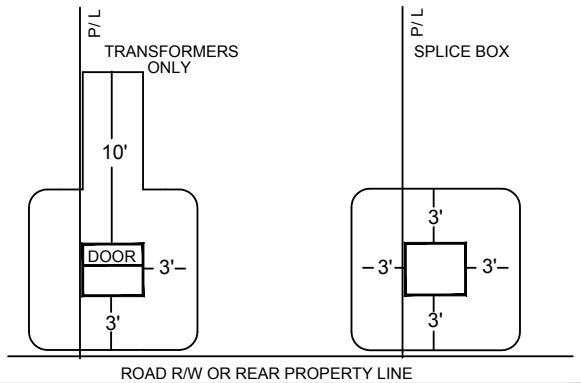

TYPICAL LG&E INSTALLATION

NOTE

CUSTOMER TO INSTALL CABLE TO WITHIN 18" OF THE TRANSFORMER (SECONDARY SIDE - SEE DETAIL BELOW), SPLICE BOX OR PEDESTAL. A MINIMUM OF 6'-0" OF SLACK CABLE MUST BE LEFT ABOVE GROUND TO MAKE CONNECTIONS. THE UTILITY WILL NOT EXCAVATE MORE THAN 18" TO INSTALL CABLES INTO UTILITY EQUIPMENT.

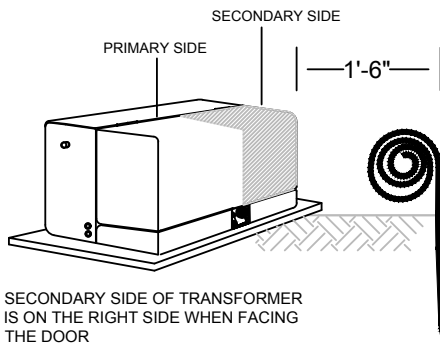

AN AREA APPROXIMATELY 4'-0" WIDE (2'-0" ON BOTH SIDES OF THE METER) SHOULD BE MADE AVAILABLE, FREE AND CLEAR OF PLANTINGS. THIS IS AN ACCESS AREA FOR THE METER READER.

IDENTIFY NEUTRAL CONDUCTOR PER N.E.C.

DO NOT PUSH SERVICE CABLES INTO PEDESTAL, SPLICE BOX OR TRANSFORMER COMPARTMENT UNLESS UTILITY PERSONNEL ARE PRESENT

FINISHED GRADE

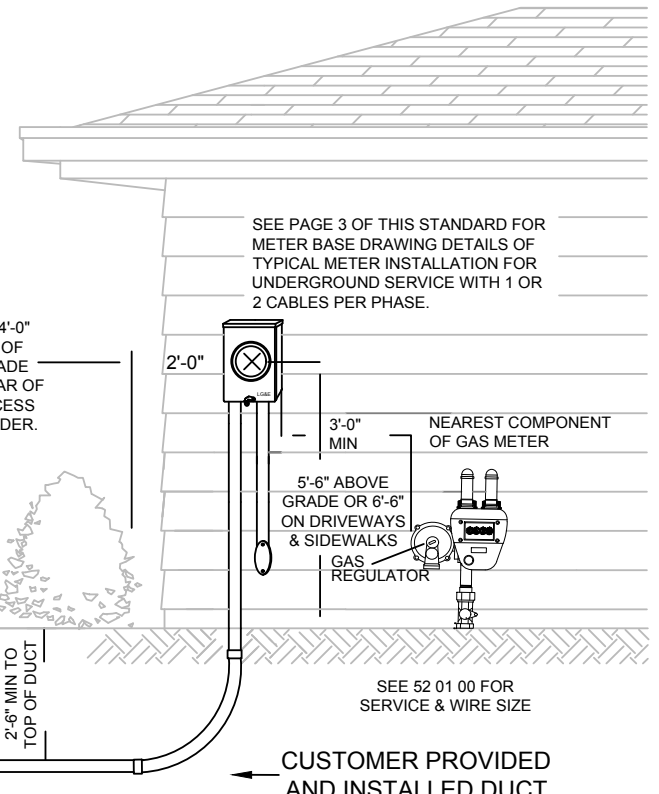

SEE PAGE 3 OF THIS STANDARD FOR METER BASE DRAWING DETAILS OF TYPICAL METER INSTALLATION FOR UNDERGROUND SERVICE WITH 1 OR 2 CABLES PER PHASE.

SEE 52 01 00 FOR SERVICE & WIRE SIZE

CUSTOMER PROVIDED AND INSTALLED DUCT

TYPICAL MAXIMUM DISTANCE 150'

TYPICAL KU INSTALLATION

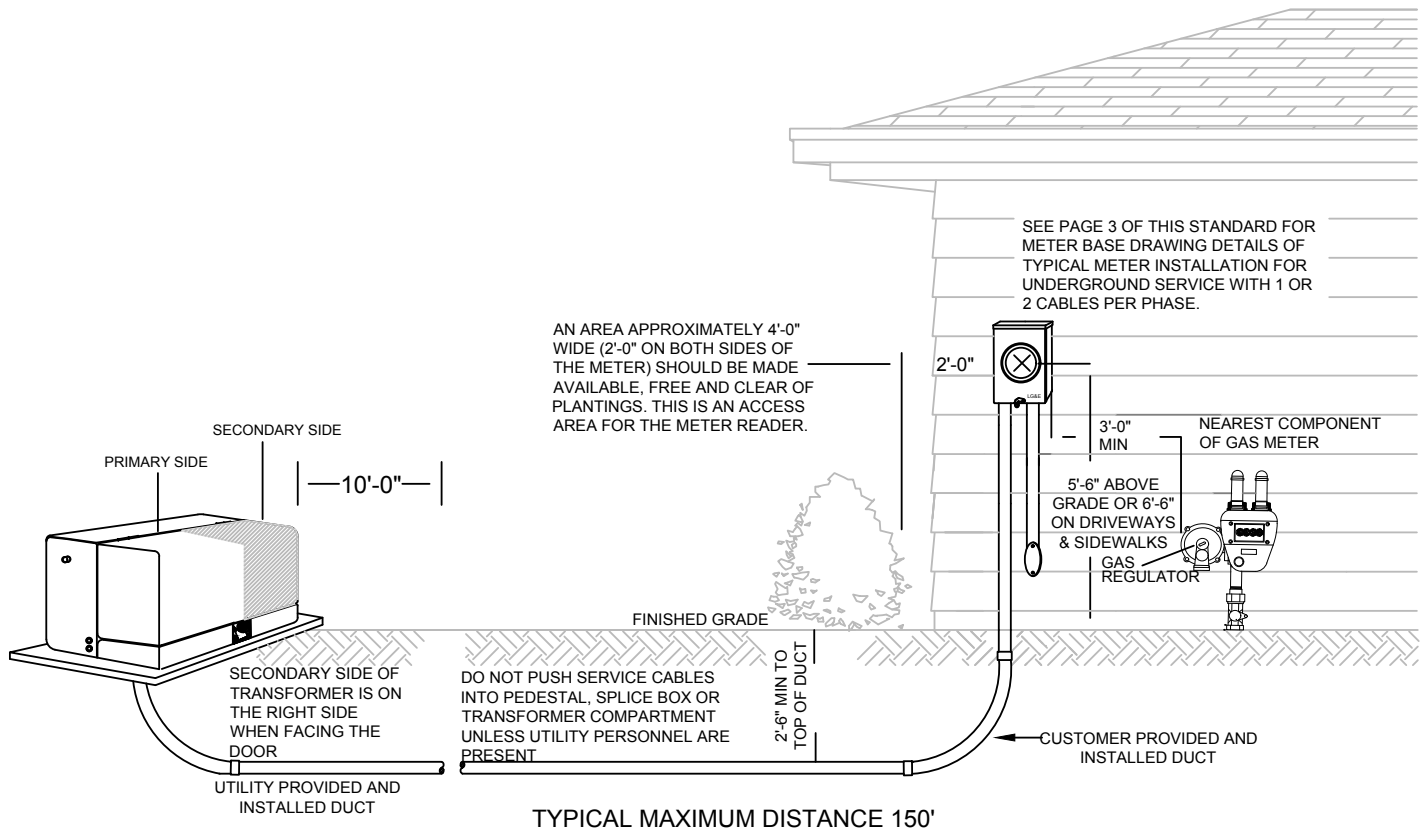

IT IS THE CONTRACTOR/ELECTRICIANS RESPONSIBILITY TO ENSURE THE INSTALLATION IS BUILT ACCORDING TO THE LATEST REVISION OF THIS DOCUMENT. THE CONTRACTOR/ELECTRICIAN SHOULD REQUEST A CURRENT VERSION OF THIS STANDARD FROM LG&E'S REPRESENTATIVE BEFORE BEGINNING CONSTRUCTION.

Service Type - Single Phase 120/240 Volt, 2 / 3 wire	Manufacturers	Catalog Numbers
125 Amp - Overhead / Underground	Milbank Durham Landis & Gyr Murray Cutler Hammer	U7487-XL-TG-KK UHT-RS101B UAT111-0P RJ193AX UHTRS101BCH
225 Amp - Overhead / Underground Lever Bypass	Milbank Durham Landis & Gyr Murray Cutler Hammer Cutler Hammer	U7040-XL-TG-KK UHT-RS212B UAT417-0P RB198AR UTH4213TCH UHTRS213BCH
320 Amp - Overhead	Milbank Durham Landis & Gyr Landis & Gyr Murray Cutler Hammer	U1079-R, U2448-X UT-H4300T 47704-01 47604-02 RK173AH UTH4336TCH
320 Amp - Underground With 200 Amp Main(s)	Milbank Durham Landis & Gyr Murray Murray Cutler Hammer	U1129-O-K3L-K2L, U1797-O-K3L-K2L, U2448-X UT-H4330T 44704-01 RK178A JAO16B1400RLTM UTH4336TCH

Catalog #'s do not reflect Hub Size, or Cover Plates.
Catalog #'s for 320 Amp bases do not include wire termination lugs.
Bases must be UL listed, have bypass capability, and be of the ringless design.

Please call for requirements on any services not listed above:

Louisville Gas & Electric Company
Electric Meter Department
(502) 364-8270

Or

KU/ODP
Customer Service
1-800-981-0600

TYPICAL METER INSTALLATION FOR UNDERGROUND SERVICE WITH 1 OR 2 CABLES PER PHASE

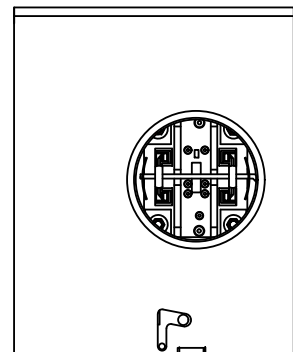
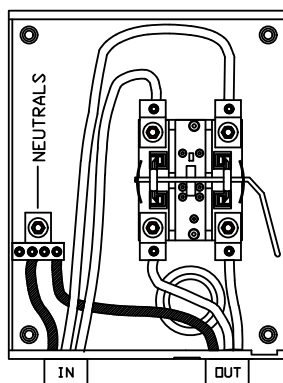
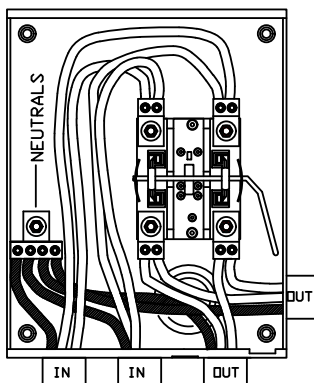

IMPORTANT NOTICE TO ELECTRICIANS / BUILDERS

ALL STRUCTURES USED FOR TEMPORARY SERVICE SHOULD BE LOCATED OUTSIDE OF THE EQUIPMENT **CLEAR WORKING ZONE** AS SHOWN IN THE DETAIL BELOW.

CONTRACTORS SHOULD USE CARE TO NOT ROUTE TEMPORARY SERVICE CONDUCTORS ACROSS, OR ALONG THE PATH INTENDED FOR THE PERMANENT SERVICE CONDUCTORS.

THE MAJORITY OF ALL UNDERGROUND SERVED RESIDENTIAL LOTS WILL HAVE EITHER A TRANSFORMER OR A SERVICE SPLICE BOX / PEDESTAL LOCATED ADJACENT TO ONE OF THE PROPERTY LINES. IN RARE CASES, A LOT MAY HAVE BOTH A TRANSFORMER AND A SPLICE BOX LOCATE ALONG PROPERTY LINES.

WHENEVER A TRANSFORMER IS LOCATED ALONG EITHER PROPERTY LINE, LOCATE THE TEMPORARY STRUCTURE ON THE SIDE OF THE LOT CLOSEST TO TRANSFORMER AND RUN THE SERVICE CONDUCTORS TO WITHIN 18" OF THE SECONDARY SIDE OF THE TRANSFORMER (SEE DETAIL).

IF **BOTH** A TRANSFORMER AND SPLICE BOX ARE PRESENT, LOCATE THE TEMPORARY STRUCTURE ON THE SIDE OF THE LOT CLOSEST TO TRANSFORMER AND RUN THE SERVICE CONDUCTORS TO WITHIN 18" OF THE SECONDARY SIDE OF THE TRANSFORMER (SEE DETAIL).

IF **ONLY** A SPLICE BOX IS PRESENT, LOCATE THE TEMPORARY STRUCTURE ON THE SIDE OF THE LOT CLOSEST TO THE SPLICE BOX AND RUN THE SERVICE CONDUCTORS TO WITHIN 18" OF THE SPLICE BOX.

IF THERE IS NEITHER A TRANSFORMER NOR A SPLICE BOX, CALL THE APPROPRIATE SERVICE LOCATOR

CLEAR WORKING ZONE AROUND UTILITY EQUIPMENT FOR TEMPORARY SERVICE STRUCTURES ONLY. FOR CLEAR WORKING ZONE AROUND PERMANENT INSTALLATIONS REFER TO CLEARANCE STICKER ON TRANSFORMER OR CONTACT YOUR UTILITY REPRESENTATIVE.

THE CLEAR WORKING ZONE DESIGNATES AN AREA AROUND UTILITY EQUIPMENT THAT MUST REMAIN FREE OF TEMPORARY SERVICE STRUCTURES AND ALL OTHER OBSTRUCTIONS, INCLUDING ANY STRUCTURES, LANDSCAPING, FENCING, ETC. THIS SPACE IS NECESSARY SO THAT UTILITY PERSONNEL CAN WORK SAFELY AROUND ENERGIZED UTILITY EQUIPMENT.

TRANSFORMERS ONLY

UTILITY WORK ZONE AREA IS DEFINED AS 10'-0" CLEARANCE IN FRONT OF THE DOOR 3'-0" AWAY FROM OTHER SIDES OF THE TRANSFORMER

ELECTRIC PEDESTAL OR SPLICE BOX

UTILITY WORK ZONE AREA IS DEFINED AS 3'-0" AROUND PEDESTAL AND SPLICE BOXES

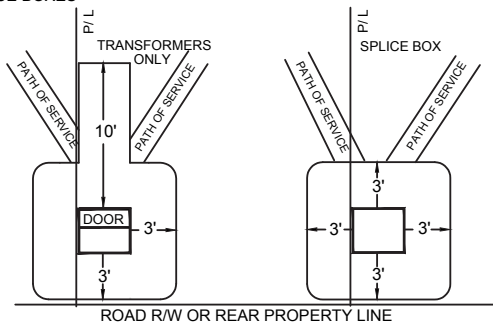

NOTE

CUSTOMER TO INSTALL CABLE TO WITHIN 18" OF THE TRANSFORMER (SECONDARY SIDE - SEE DETAIL BELOW), SPLICE BOX OR PEDESTAL. A MINIMUM OF 6'-0" OF SLACK CABLE MUST BE LEFT ABOVE GROUND TO MAKE CONNECTIONS. THE UTILITY WILL NOT EXCAVATE MORE THAN 18" TO INSTALL CABLES INTO UTILITY EQUIPMENT.

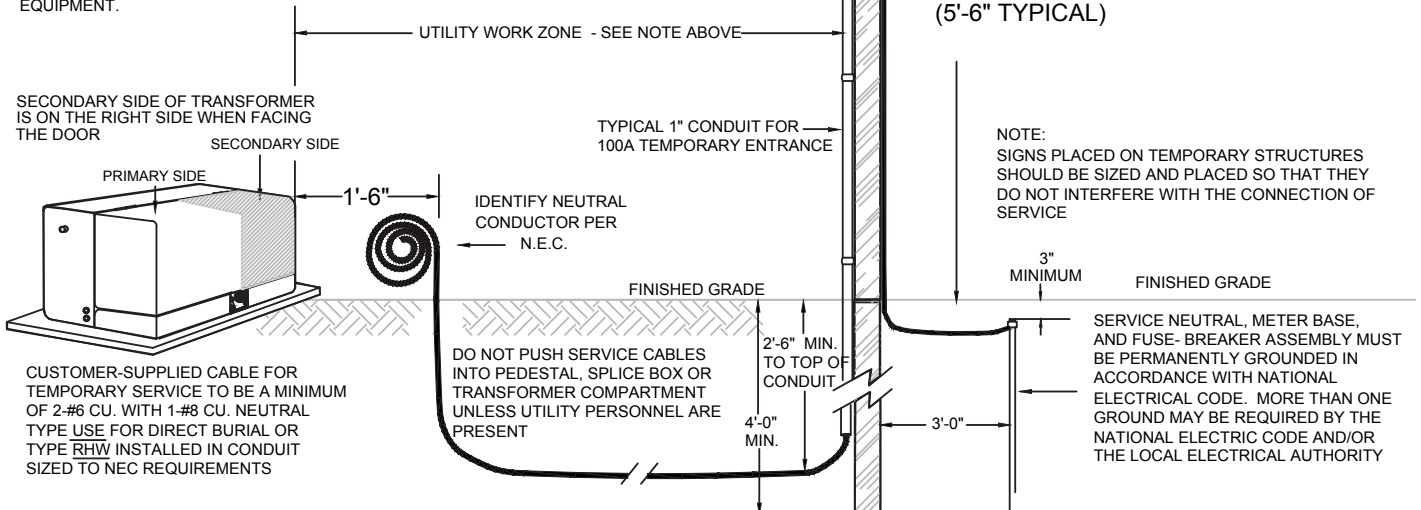

REQUIREMENTS FOR SERVICE

SERVICE CONNECTIONS CANNOT BE MADE UNTIL THE FOLLOWING CONDITIONS HAVE BEEN MET.

1. A RESPONSIBLE PERSON HAS APPLIED FOR SERVICE.
2. UTILITY HAS BEEN NOTIFIED BY THE APPROPRIATE INSPECTION AUTHORITY THAT THE INSTALLATION HAS BEEN INSPECTED AND APPROVED FOR SERVICE.
3. CONTRACTOR HAS REQUESTED SERVICE BE CONNECTED.
4. ALL UTILITY REQUIREMENTS FOR SERVICE HAVE BEEN MET AND THE INSTALLATION HAS BEEN ACCEPTED BY UTILITY.

SHOULD ANY OF THE CONDITIONS REQUIRED FOR SERVICE NOT BE MET, SERVICE WILL NOT BE CONNECTED AND THE UTILITY MAY IMPOSE AN APPROPRIATE CHARGE TO COVER THE COST TO RETURN AND CONNECT THE SERVICE.

MATERIAL AND INSTALLATION

1. UTILITY WILL PROVIDE AND INSTALL THE ELECTRIC METER.
2. CONTRACTOR MUST FURNISH AND INSTALL THE METER BASE FOR TEMPORARY SERVICES. CONTRACTOR TO PROVIDE A METER BASE APPROVED BY UTILITY. SEE THE ELECTRIC SERVICE HANDBOOK AVAILABLE AT WWW.LGE-KU.COM FOR MORE INFORMATION.
3. ALL OTHER MATERIAL IS TO BE FURNISHED AND INSTALLED BY THE CONTRACTOR IN CONFORMANCE WITH THE NATIONAL ELECTRIC CODE AND THE REQUIREMENTS OF THE INSPECTION AUTHORITY HAVING JURISDICTION.

ONE 2" X 6" OR ONE 4" X 4" OR TWO 2" X 4" TIMBERS.
(SPLICED TIMBERS ARE NOT ACCEPTABLE)

2017 N.E.C. 590.6 REQUIRES APPROVED GROUND FAULT CIRCUIT PROTECTORS ON ALL 15 AND 20 AMP SINGLE PHASE RECEPTACLE OUTLETS.

(5'-6" TYPICAL)

NOTE:
SIGNS PLACED ON TEMPORARY STRUCTURES SHOULD BE SIZED AND PLACED SO THAT THEY DO NOT INTERFERE WITH THE CONNECTION OF SERVICE

3" MINIMUM FINISHED GRADE

SERVICE NEUTRAL, METER BASE, AND FUSE-BREAKER ASSEMBLY MUST BE PERMANENTLY GROUNDED IN ACCORDANCE WITH NATIONAL ELECTRICAL CODE. MORE THAN ONE GROUND MAY BE REQUIRED BY THE NATIONAL ELECTRICAL CODE AND/OR THE LOCAL ELECTRICAL AUTHORITY

NOTE:

- 120/240V 1Ø 3W CONDUCTOR SHALL NOT EXCEED THE LG&E CO. LIMITATIONS FOR SINGLE PHASE SERVICE ENTRANCES: MAX. RESIDENTIAL OVERHEAD = 800A, UNDERGROUND = 1200A
- THE C.T. ENCLOSURE SHALL NOT BE USED AS AN AUXILIARY GUTTER OR JUNCTION BOX.
- DIAGRAM SHOWN FOR OH SERVICE. FOR UG SERVICE, ROTATE INTERNAL LAYOUT 180°.

MINIMUM C.T. ENCLOSURE SIZE USING UP TO 5 CABLES (NOT SHOWN) PER PHASE 120/240V 1Ø 3W >400 - 1200 A

METER BASE TO BE GROUNDED TO SYSTEM GROUND WITH MINIMUM #6 COPPER

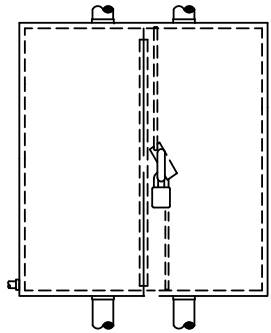
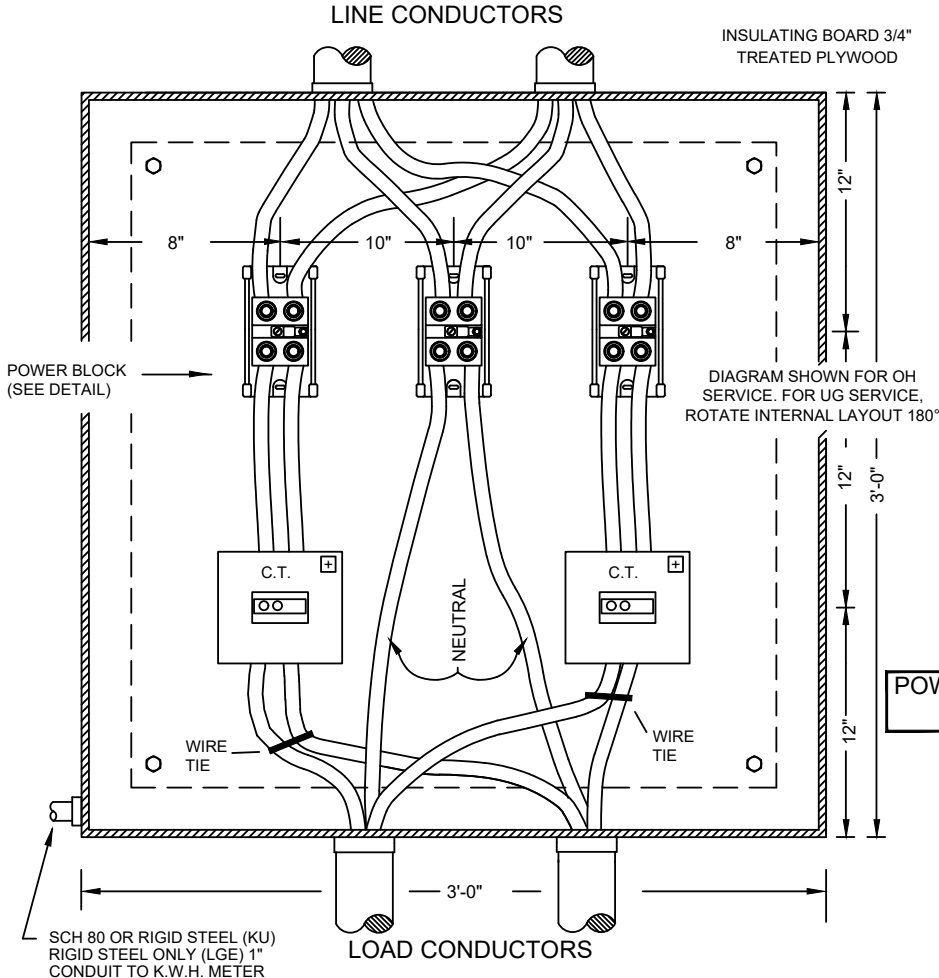

SEE STANDARD 81 10 00 FOR VARIOUS CABINET SIZES AND SPECIFICATIONS.

* IMPORTANT * OUTDOOR INSTALLATIONS MUST USE NEMA 3R HUBS IN TOP OF CABINET

POWER BLOCK DETAIL LUG FOR TAP SCREWED TO TOP OF BLOCK

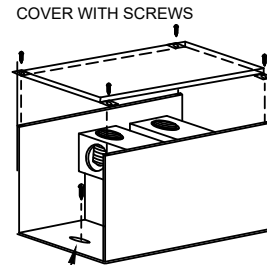

ATTACH BLOCK TO PLYWOOD WITH (2) SCREWS. (1) REAR. (1) FRONT.

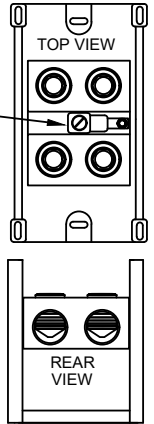

NUMBER OF CONDUCTORS	MAXIMUM CONDUCTOR SIZE	
	COPPER	ALUMINUM
PARALLEL (MAX. OF 2 PER LEG) 800A	500MCM	500MCM
PARALLEL (MAX. OF 5 PER LEG) 1200A	600MCM	600MCM
EQUIPMENT	FURNISHED BY	INSTALLED BY
C.T. ENCLOSURE, GROUNDING LUGS, PLYWOOD, POWER BLOCKS AND CONDUIT	CONTRACTOR	CONTRACTOR
C.T.'S, TEST BOXES	UTILITY	CONTRACTOR
SECONDARY WIRING	UTILITY	UTILITY

*FOR 1200A SERVICES MINIMUM CABINET SIZE 48"X48"X14" IS REQUIRED DUE TO SIZE OF C.T.'S

CONTRACTOR NOTES:

- CONTRACTOR SHALL PROVIDE BONDING FOR C.T. & METER BASE AND SHALL GROUND EQUIPMENT PER N.E.C. AND LOCAL CODES.
- CONTRACTOR SHALL INSTALL EQUIPMENT AT THE LOCATION DESIGNATED BY LG&E SERVICE LOCATORS OR METER DEPARTMENT SUPERVISORS.
- THE POLARITY MARKS ON EACH CURRENT TRANSFORMER SHOULD POINT TOWARD THE LINE OR FEED CONDUCTORS.
- THE INSTALLATION MUST BE ACCEPTABLE TO UTILITY BEFORE THE SERVICE IS ENERGIZED.
- LINE CONDUCTORS SHALL ENTER & LOAD CONDUCTORS SHALL EXIT ON OPPOSITE SIDES OF THE CABINET (i.e. BOTTOM TO TOP OR SIDE TO SIDE). POWER BLOCK & C.T. LAYOUT SHALL BE ROTATED AS NECESSARY TO KEEP POWER BLOCKS CONNECTED ON LINE SIDE OF C.T.
- POWER BLOCKS SHALL BE 2 LUG ILSKO #LDB-22-500-LG, IIN 3023975 (WHICH INCLUDES ILSKO #SLUH-90 LUG FOR TAP), 5 LUG ILSKO #PDB-55-600-1 OR PDB-55-500-1 OR APPROVED EQUAL.
- PROVIDE WIRE TIES FOR MULTIPLE CABLES PER LEG TO KEEP THE CABLES FROM PUTTING STRAIN ON C.T.

WINDOW TYPE CT

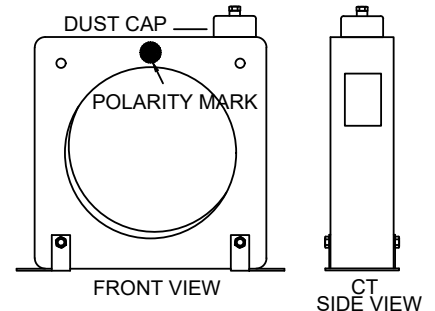

NOTE:
1. THE C.T. ENCLOSURE SHALL NOT BE USED AS AN AUXILIARY GUTTER OR JUNCTION BOX.
2. DIAGRAM SHOWN FOR OH SERVICE. FOR UG SERVICE, ROTATE INTERNAL LAYOUT 180°.

MINIMUM C.T. ENCLOSURE SIZE USING 1 OR 2 CABLES PER PHASE 240V 3Ø 3W (>400-800A MAX.)

METER BASE TO BE GROUNDED TO SYSTEM GROUND WITH MINIMUM #6 COPPER

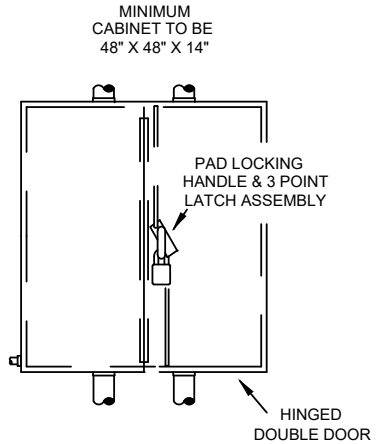
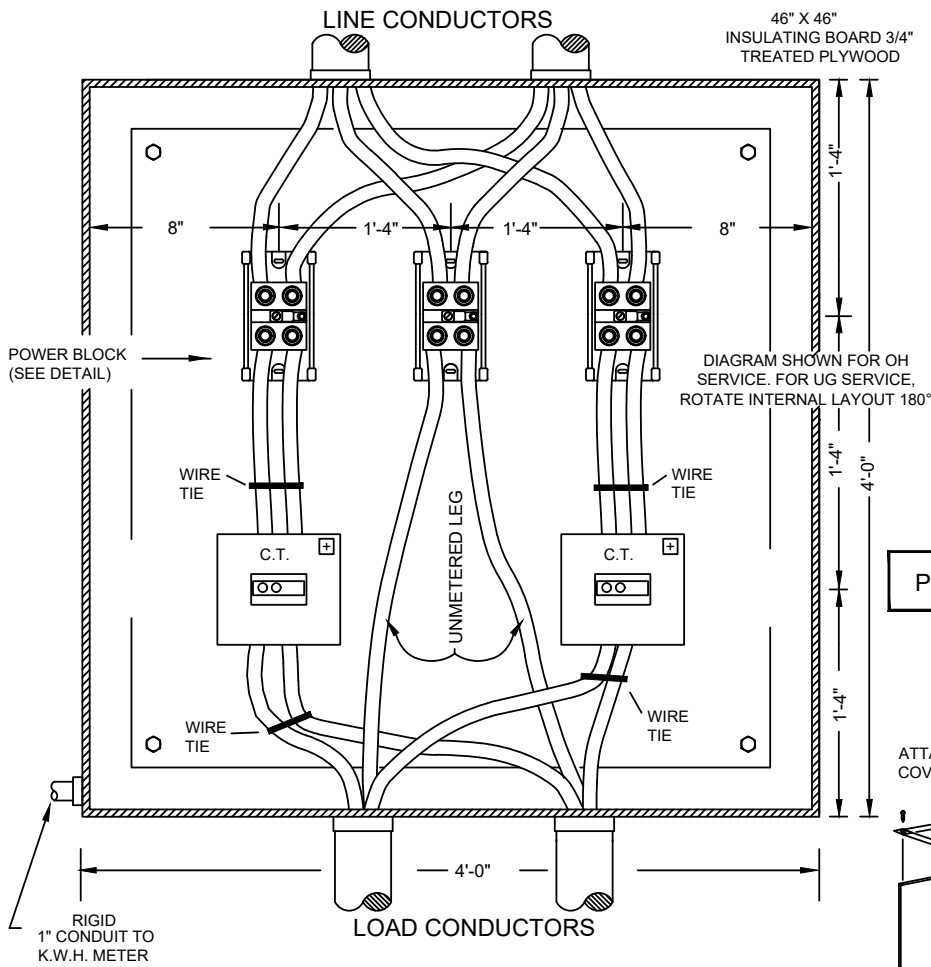

POWER BLOCK DETAIL

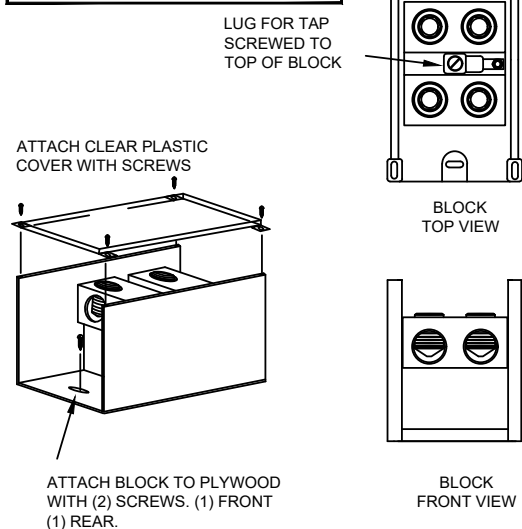

NUMBER OF CONDUCTORS	MAXIMUM CONDUCTOR SIZE	
	COPPER	ALUMINUM
SINGLE (MAX. OF 1 PER LEG)	500CM	500CM
PARALLEL (MAX. OF 2 PER LEG)	500CM	500CM
EQUIPMENT	FURNISHED BY	INSTALLED BY
C.T.'S, C.T. ENCLOSURE, GROUNDING, LUGS, PLYWOOD, POWER BLOCKS, CONDUIT AND METER ENCLOSURE	CONTRACTOR	CONTRACTOR
METER AND SECONDARY WIRING	UTILITY	UTILITY

WINDOW TYPE CT

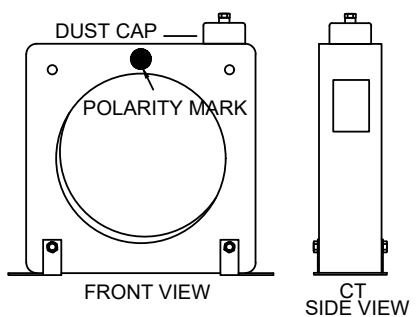

- CONTRACTOR NOTES:
- CONTRACTOR SHALL PROVIDE BONDING FOR C.T. & METER BASE AND SHALL GROUND EQUIPMENT PER N.E.C. AND LOCAL CODES.
 - CONTRACTOR SHALL INSTALL EQUIPMENT AT THE LOCATION DESIGNATED BY LG&E/KU SERVICE LOCATORS OR METER DEPARTMENT SUPERVISORS.
 - THE POLARITY MARKS ON EACH CURRENT TRANSFORMER SHOULD POINT TOWARD THE LINE OR FEED CONDUCTORS.
 - THE INSTALLATION MUST BE ACCEPTABLE TO LG&E/KU BEFORE THE SERVICE IS ENERGIZED.
 - POWER BLOCK & C.T. LAYOUT SHALL BE ROTATED AS NECESSARY TO KEEP POWER BLOCKS CONNECTED ON LINE SIDE OF C.T.
 - POWER BLOCKS SHALL BE ILSCO #LDB-22-500-LG IIN 3023975 (WHICH INCLUDES ILSCO #SLUH-90 LUG FOR TAP) OR APPROVED EQUAL.
 - PROVIDE WIRE TIES FOR MULTIPLE CABLES PER LEG TO KEEP THE CABLES FROM PUTTING STRAIN ON C.T.

- NOTE:
1. THE C.T. ENCLOSURE SHALL NOT BE USED AS AN AUXILIARY GUTTER OR JUNCTION BOX.
2. DIAGRAM SHOWN FOR OH SERVICE. FOR UG SERVICE, ROTATE INTERNAL LAYOUT 180°.

MINIMUM C.T. ENCLOSURE SIZE USING 1 OR 2 CABLES PER PHASE 480V 3Ø 3W - (>200-800A MAX.)

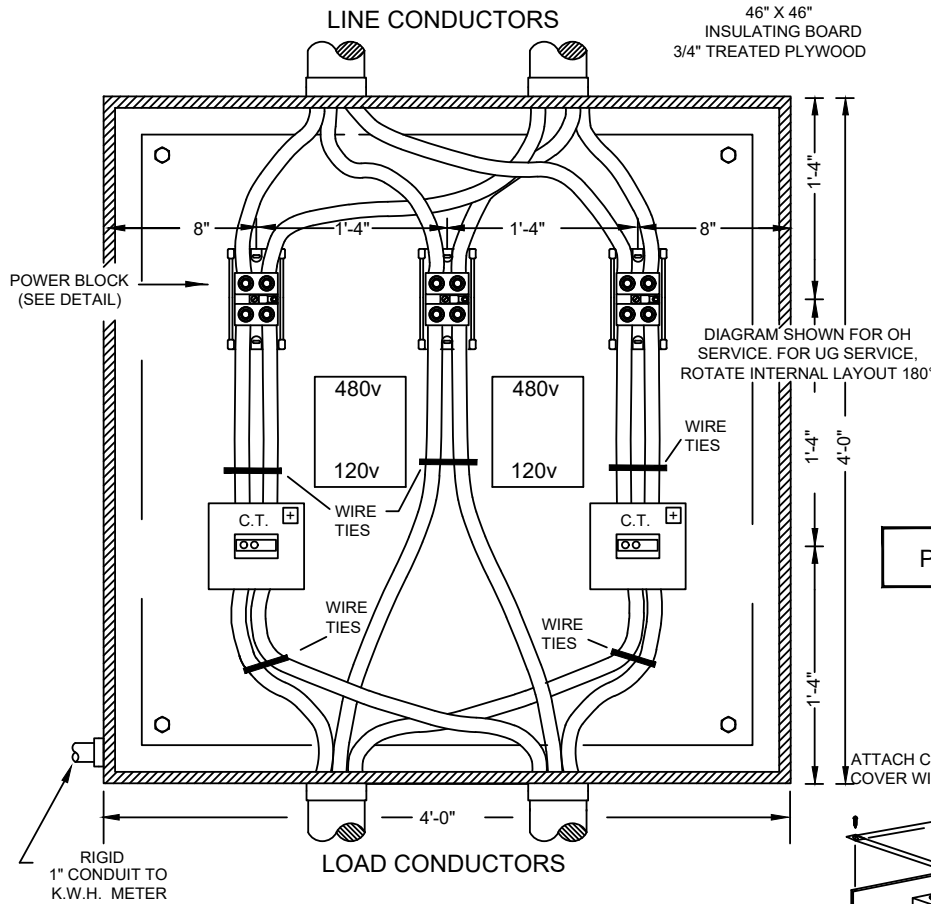

METER BASE TO BE GROUNDED TO SYSTEM GROUND WITH MINIMUM #6 COPPER

MINIMUM CABINET TO BE 48" X 48" X 14"

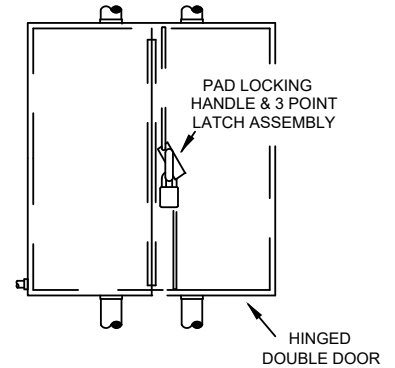

POWER BLOCK DETAIL

LUG FOR TAP SCREWED TO TOP OF BLOCK

ATTACH CLEAR PLASTIC COVER WITH SCREWS

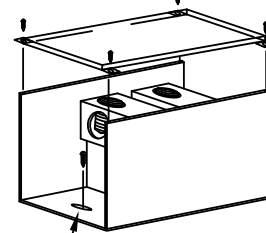

ATTACH BLOCK TO PLYWOOD WITH (2) SCREWS. (1) FRONT (1) REAR.

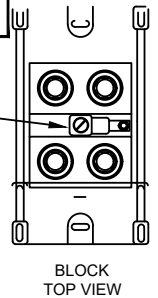

BLOCK TOP VIEW

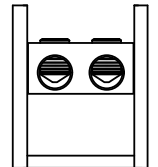

BLOCK FRONT VIEW

NUMBER OF CONDUCTORS	MAXIMUM CONDUCTOR SIZE	
	COPPER	ALUMINUM
SINGLE (MAX. OF 1 PER LEG)	500CM	500CM
PARALLEL (MAX. OF 2 PER LEG)	500CM	500CM

EQUIPMENT	FURNISHED BY	INSTALLED BY
C.T.'S, C.T. ENCLOSURE, GROUNDING, LUGS, PLYWOOD, POWER BLOCKS, CONDUIT AND METER ENCLOSURE	CONTRACTOR	CONTRACTOR
METER AND SECONDARY WIRING	UTILITY	UTILITY

WINDOW TYPE CT

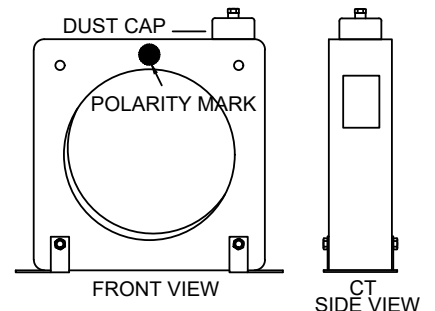

FRONT VIEW

CT SIDE VIEW

CONTRACTOR NOTES:

- CONTRACTOR SHALL PROVIDE BONDING FOR C.T. & METER BASE AND SHALL GROUND EQUIPMENT PER N.E.C. AND LOCAL CODES.
- CONTRACTOR SHALL INSTALL EQUIPMENT AT THE LOCATION DESIGNATED BY LG&E/KU SERVICE LOCATOR/DESIGNER OR METER DEPARTMENT SUPERVISORS.
- THE POLARITY MARKS ON EACH CURRENT TRANSFORMER SHOULD POINT TOWARD THE LINE OR FEED CONDUCTORS.
- THE INSTALLATION MUST BE ACCEPTABLE TO LG&E/KU BEFORE THE SERVICE IS ENERGIZED.
- POWER BLOCK & C.T. LAYOUT SHALL BE ROTATED AS NECESSARY TO KEEP POWER BLOCKS CONNECTED ON LINE SIDE OF C.T.
- POWER BLOCKS SHALL BE ILSKO #LDB-22-500-LG IIN 3023975 (WHICH INCLUDES ILSKO #SLUH-90 LUG FOR TAP) OR APPROVED EQUAL.
- PROVIDE WIRE TIES FOR MULTIPLE CABLES PER LEG TO KEEP THE CABLES FROM PUTTING STRAIN ON C.T.

NOTE:

1. THE C.T. ENCLOSURE SHALL NOT BE USED AS AN AUXILIARY GUTTER OR JUNCTION BOX.
2. DIAGRAM SHOWN FOR OH SERVICE. FOR UG SERVICE, ROTATE INTERNAL LAYOUT 180°.

MINIMUM C.T. ENCLOSURE SIZE USING 1 OR 2 CABLES PER PHASE
120/208V 3Ø 4W >400-800A - 277/480V 3Ø 4W - >200-800AMP MAX (LGE/KU)
120/240V 3Ø 4W >400-800A

METER BASE TO BE
GROUNDED TO
SYSTEM GROUND
WITH MINIMUM #6
COPPER

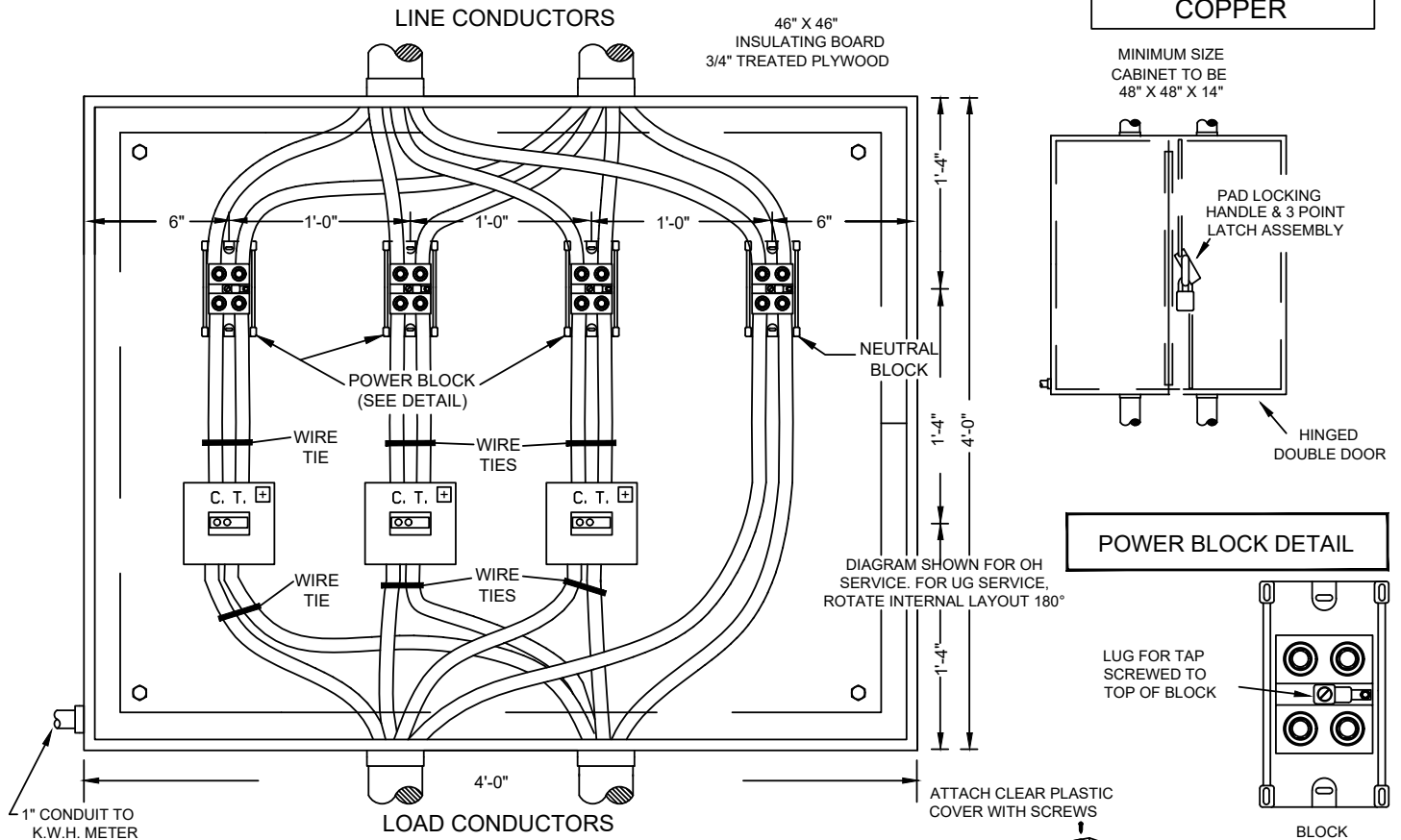

NUMBER OF CONDUCTORS	MAXIMUM CONDUCTOR SIZE	
	COPPER	ALUMINUM
SINGLE (MAX OF 1 PER LEG)	500MCM	500MCM
PARALLEL (MAX OF 2 PER LEG)	500MCM	500MCM

EQUIPMENT	FURNISHED BY	INSTALLED BY
C.T. ENCLOSURE, GROUNDING, LUGS, PLYWOOD, POWER BLOCKS AND CONDUIT	CONTRACTOR	CONTRACTOR
C.T.'S AND METER ENCLOSURES	UTILITY	CONTRACTOR
METER AND SECONDARY WIRING	UTILITY	UTILITY

CONTRACTOR NOTES:

1. CONTRACTOR SHALL PROVIDE BONDING FOR C.T. & METER BASE AND SHALL GROUND EQUIPMENT PER N.E.C. AND LOCAL CODES.
2. CONTRACTOR SHALL INSTALL EQUIPMENT AT THE LOCATION DESIGNATED BY LG&E/KU SERVICE LOCATOR/DESIGNER OR METER DEPARTMENT SUPERVISORS.
3. THE POLARITY MARKS ON EACH CURRENT TRANSFORMER SHOULD POINT TOWARD THE LINE OR FEED CONDUCTORS.
4. THE INSTALLATION MUST BE ACCEPTABLE TO LG&E/KU BEFORE THE SERVICE IS ENERGIZED.
5. LINE CONDUCTORS SHALL ENTER & LOAD CONDUCTORS SHALL EXIT ON OPPOSITE SIDES OF THE CABINET (i.e. BOTTOM TO TOP OR SIDE TO SIDE). POWER BLOCKS & C.T. LAYOUT SHALL BE ROTATED AS NECESSARY TO KEEP POWER BLOCKS CONNECTED ON LINE SIDE OF C.T.
6. POWER BLOCKS SHALL BE ILSCO #LDB-22-500-LG IIN 3023975 (WHICH INCLUDES ILSCO #SLUH-90 LUG FOR TAP) OR APPROVED EQUAL.
7. PROVIDE WIRE TIES FOR MULTIPLE CABLES PER LEG TO KEEP THE CABLES FROM PUTTING STRAIN ON C.T.

WINDOW TYPE CT

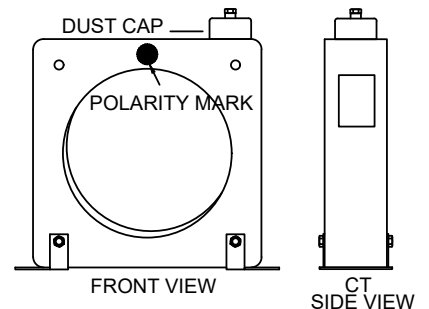

- NOTE:
1. THE C.T. ENCLOSURE SHALL NOT BE USED AS AN AUXILIARY GUTTER OR JUNCTION BOX.
 2. DIAGRAM SHOWN FOR OH SERVICE. FOR UG SERVICE, ROTATE INTERNAL LAYOUT 180°.

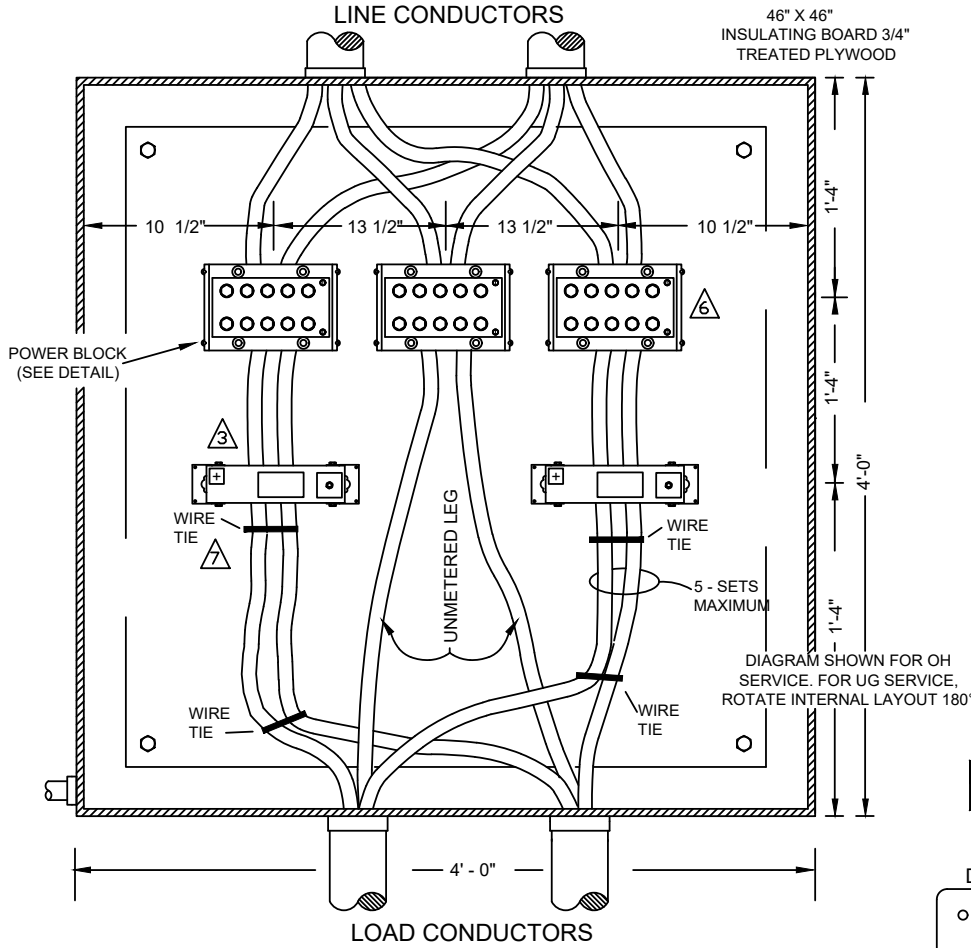

METER BASE TO BE GROUNDED TO SYSTEM GROUND WITH MINIMUM #6 COPPER

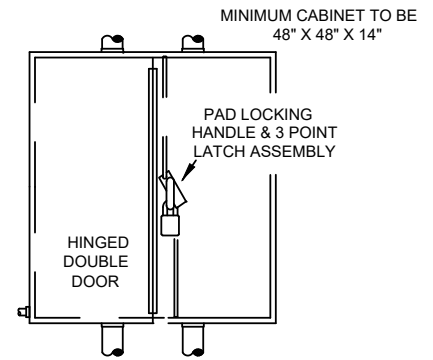

WINDOW TYPE CT

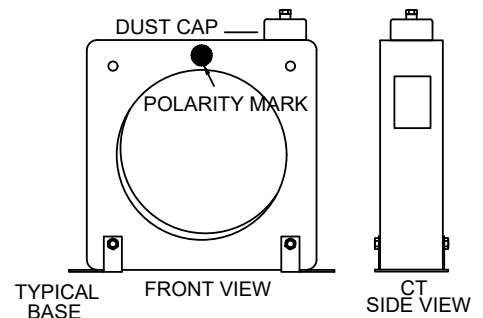

NUMBER OF CONDUCTORS	MAXIMUM CONDUCTOR SIZE	
	MAX SERVICE	MAX CONDUCTOR
PDB-55-500-1	1600A	500 CU. OR AL.
PDB-55-600-1	2000A	600 CU. ONLY

EQUIPMENT	FURNISHED BY	INSTALLED BY
C.T. ENCLOSURE, GROUNDING LUGS, PLYWOOD, POWER BLOCKS AND CONDUIT	CONTRACTOR	CONTRACTOR
C.T.'S, P.T.'S AND TEST BOXES	UTILITY	CONTRACTOR
METER AND SECONDARY WIRING	UTILITY	UTILITY

CONTRACTOR NOTES:

1. CONTRACTOR SHALL PROVIDE BONDING FOR C.T. & METER BASE AND SHALL GROUND EQUIPMENT PER N.E.C. AND LOCAL CODES.
2. CONTRACTOR SHALL INSTALL EQUIPMENT AT THE LOCATION DESIGNATED BY LG&E/KU SERVICE LOCATOR/DESIGNER OR METER DEPARTMENT SUPERVISORS.
3. THE POLARITY MARKS ON EACH CURRENT TRANSFORMER SHOULD POINT TOWARD THE LINE OR SOURCE CONDUCTORS.
4. THE INSTALLATION MUST BE ACCEPTABLE TO LG&E/KU BEFORE THE SERVICE IS ENERGIZED.
5. POWER BLOCKS & C.T. LAYOUT SHALL BE ROTATED AS NECESSARY TO KEEP POWER BLOCKS CONNECTED ON LINE SIDE OF C.T.
6. POWER BLOCKS SHALL BE ILS CO #PDB-55-600-1 OR PDB-55-500-1 OR APPROVED EQUAL
7. PROVIDE WIRE TIES FOR MULTIPLE CABLES PER LEG TO KEEP THE CABLES FROM PUTTING STRAIN ON C.T.

POWER BLOCK DETAIL

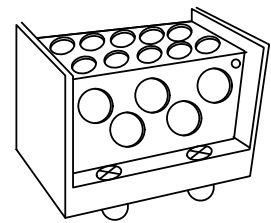

APPROVED 5 - POSITION POWER BLOCK
ILSCO PDB-55-600-1
ILSCO PDB-55-500-1

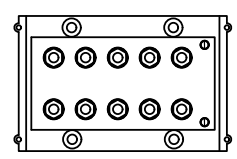

BLOCK TOP VIEW

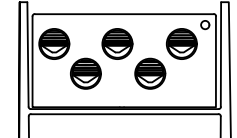

BLOCK FRONT VIEW

NOTE:

1. THE C.T. ENCLOSURE SHALL NOT BE USED AS AN AUXILIARY GUTTER OR JUNCTION BOX.
2. DIAGRAM SHOWN FOR OH SERVICE. FOR UG SERVICE, ROTATE INTERNAL LAYOUT 180°.

MINIMUM C.T. ENCLOSURE SIZE USING UP TO 5 CABLES PER PHASE
480V 3Ø 3W >800 AMP - 2000A MAX

METER BASE TO BE
GROUNDED TO
SYSTEM GROUND
WITH MINIMUM #6
COPPER

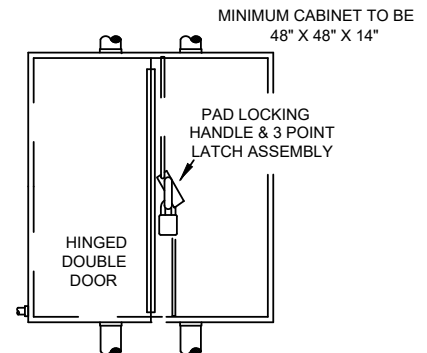
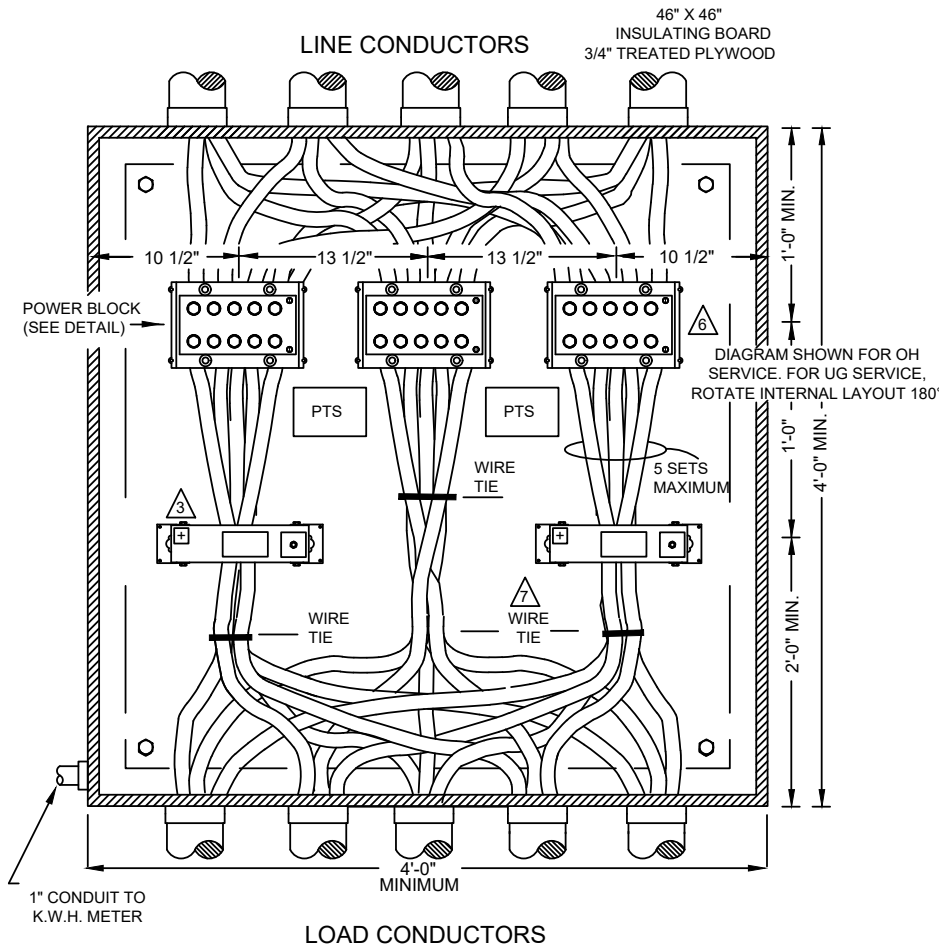

WINDOW TYPE CT

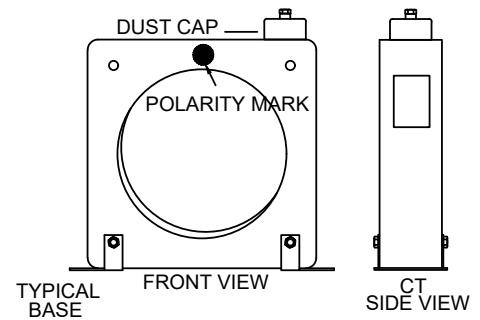

NUMBER OF CONDUCTORS	MAXIMUM CONDUCTOR SIZE	
	MAX SERVICE	MAX CONDUCTOR
PDB-55-500-1	1600A	500 CU. OR AL.
PDB-55-600-1	2000A	600 CU. ONLY

EQUIPMENT	FURNISHED BY	INSTALLED BY
C.T. ENCLOSURE, GROUNDING, LUGS, PLYWOOD, POWER BLOCKS AND CONDUIT	CONTRACTOR	CONTRACTOR
C.T.'S, P.T.'S AND TEST BOXES	UTILITY	CONTRACTOR
METER AND SECONDARY WIRING	UTILITY	UTILITY

POWER BLOCK DETAIL

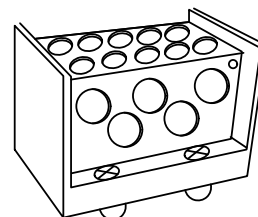

ILSCO PDB-55-600-1
ILSCO PDB-55-500-1

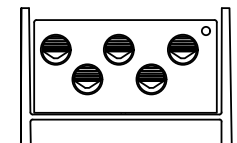
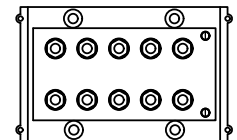

CONTRACTOR NOTES:

1. CONTRACTOR SHALL PROVIDE BONDING FOR C.T. & METER BASE AND SHALL GROUND EQUIPMENT PER N.E.C. AND LOCAL CODES.
2. CONTRACTOR SHALL INSTALL EQUIPMENT AT THE LOCATION DESIGNATED BY LG&E/KU SERVICE LOCATOR/DESIGNER OR METER DEPARTMENT SUPERVISORS.
3. THE POLARITY MARKS ON EACH CURRENT TRANSFORMER SHOULD POINT TOWARD THE LINE OR SOURCE CONDUCTORS.
4. THE INSTALLATION MUST BE ACCEPTABLE TO LG&E/KU BEFORE THE SERVICE IS ENERGIZED.
5. POWER BLOCKS & C.T. LAYOUT SHALL BE ROTATED AS NECESSARY TO KEEP POWER BLOCKS CONNECTED ON LINE SIDE OF C.T.
6. POWER BLOCKS SHALL BE ILSCO #PDB-55-600-1 OR PDB-55-500-1 OR APPROVED EQUAL
7. PROVIDE WIRE TIES FOR MULTIPLE CABLES PER LEG TO KEEP THE CABLES FROM PUTTING STRAIN ON C.T.

NOTE:

1. THE C.T. ENCLOSURE SHALL NOT BE USED AS AN AUXILIARY GUTTER OR JUNCTION BOX.
2. DIAGRAM SHOWN FOR OH SERVICE. FOR UG SERVICE, ROTATE INTERNAL LAYOUT 180°.

MINIMUM C.T. ENCLOSURE SIZE USING UP TO 5 CABLES PER PHASE
120/208V 3Ø 4W - 277/480V 3Ø 4W >800AMP - 2000 MAX

METER BASE TO BE
GROUNDED TO
SYSTEM GROUND
WITH MINIMUM #6
COPPER

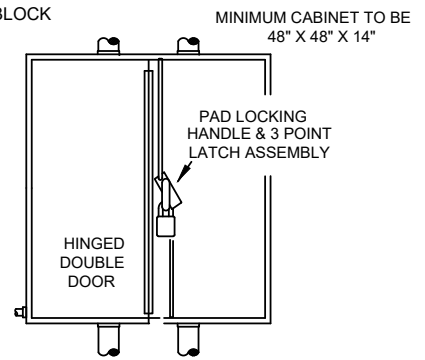
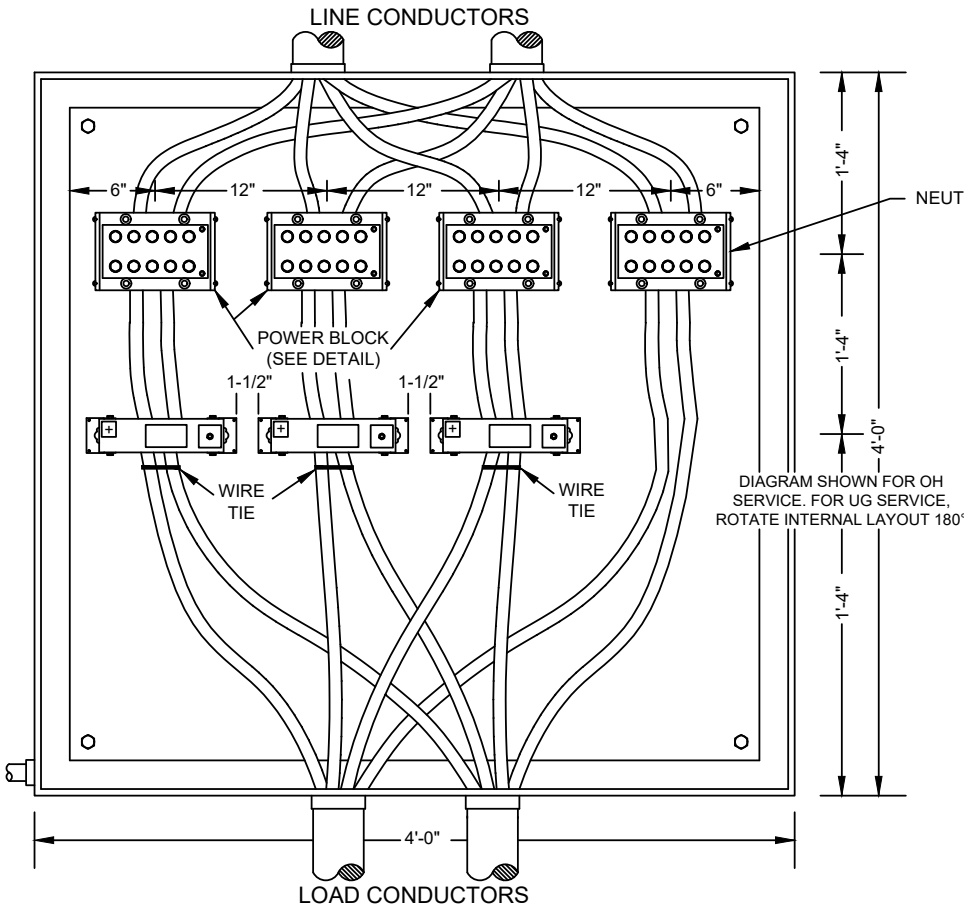

WINDOW TYPE CT

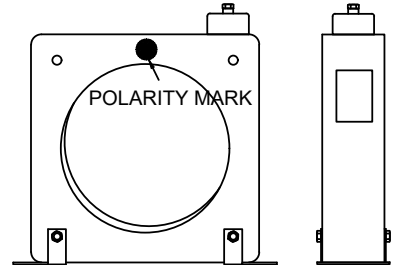

NUMBER OF CONDUCTORS	MAXIMUM CONDUCTOR SIZE	
	COPPER	ALUMINUM
PARALLEL (MAX OF 5 PER LEG)	600MCM	600MCM

EQUIPMENT	FURNISHED BY	INSTALLED BY
C.T. ENCLOSURE, GROUNDING LUGS, PLYWOOD, POWER BLOCKS AND CONDUIT	CONTRACTOR	CONTRACTOR
C.T.'S AND TEST BOXES	UTILITY	CONTRACTOR
METER AND SECONDARY WIRING	UTILITY	UTILITY

CONTRACTOR NOTES:

1. CONTRACTOR SHALL PROVIDE BONDING FOR C.T. & METER BASE AND SHALL GROUND EQUIPMENT PER N.E.C. AND LOCAL CODES.
2. CONTRACTOR SHALL INSTALL EQUIPMENT AT THE LOCATION DESIGNATED BY LG&E/KU SERVICE LOCATOR/DESIGNER OR METER DEPARTMENT SUPERVISORS.
3. THE POLARITY MARKS ON EACH CURRENT TRANSFORMER SHOULD POINT TOWARDS THE LINE OR FEED CONDUCTORS.
4. THE INSTALLATION MUST BE ACCEPTABLE TO LG&E/KU BEFORE THE SERVICE IS ENERGIZED.
5. POWER BLOCKS & C.T. LAYOUT SHALL BE ROTATED AS NECESSARY TO KEEP POWER BLOCKS CONNECTED ON LINE SIDE OF C.T.
6. POWER BLOCKS SHALL BE ILSCO #PDB-55-600-1 OR PDB-55-500-1 OR APPROVED EQUAL.
7. PROVIDE WIRE TIES FOR MULTIPLE CABLES PER LEG TO KEEP THE CABLES FROM PUTTING STRAIN ON C.T.

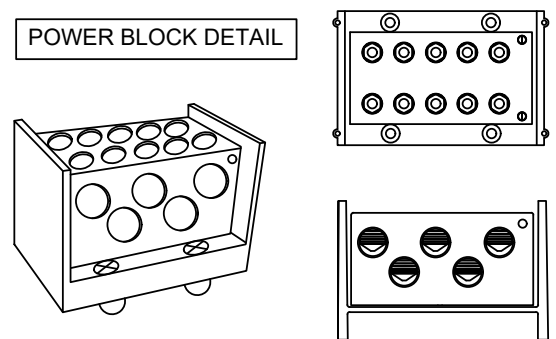

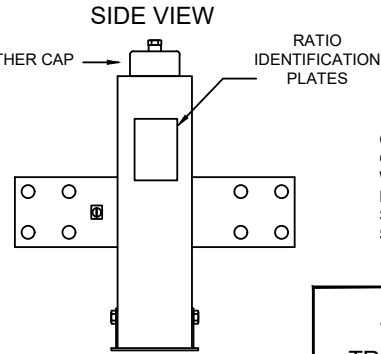
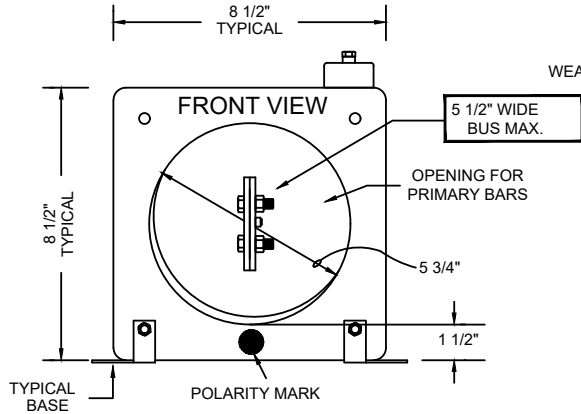
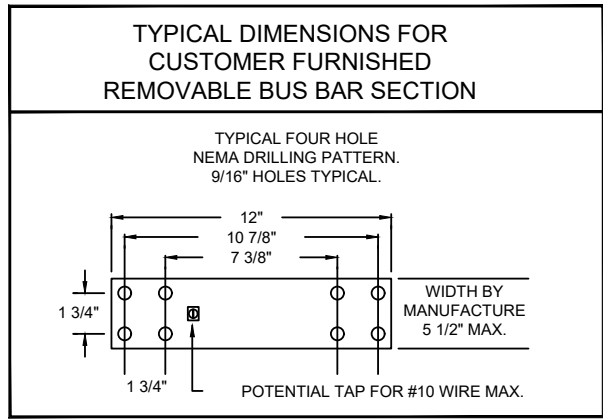
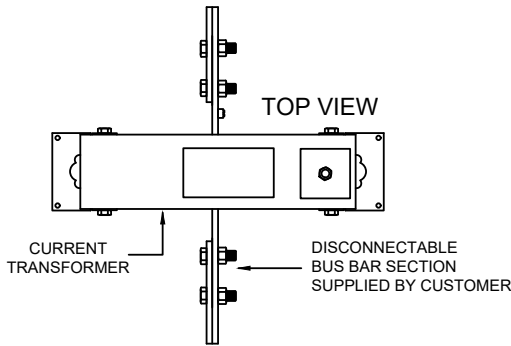

WINDOW TYPE CURRENT TRANSFORMER INSTALLATION

METERING COMPARTMENT FOR SWITCH GEAR

NOTES:
DIMENSIONS AS NOTED ARE MINIMUM STANDARDS FOR C.T. SEPARATION. DISTANCE BETWEEN LIVE PARTS SHOULD NOT BE LESS THAN 2".

CONTRACTORS ARE REQUESTED TO CALL LG&E/KU BEFORE PROCEEDING WITH SAME.

1" CONDUIT TO BE INSTALLED FROM METER BASE INTO C.T. COMPARTMENT AND STUBBED OFF.

CURRENT TRANSFORMERS TO BE FURNISHED BY LG&E/KU.

COPPER OR ALUMINUM BUS BAR CAPACITY AS REQUIRED.

480V ENTRANCE REQUIRES SEALABLE ENCLOSURE FOR POTENTIAL TRANSFORMER. SEE PAGE #2 OF THIS STANDARD FOR DETAILS.

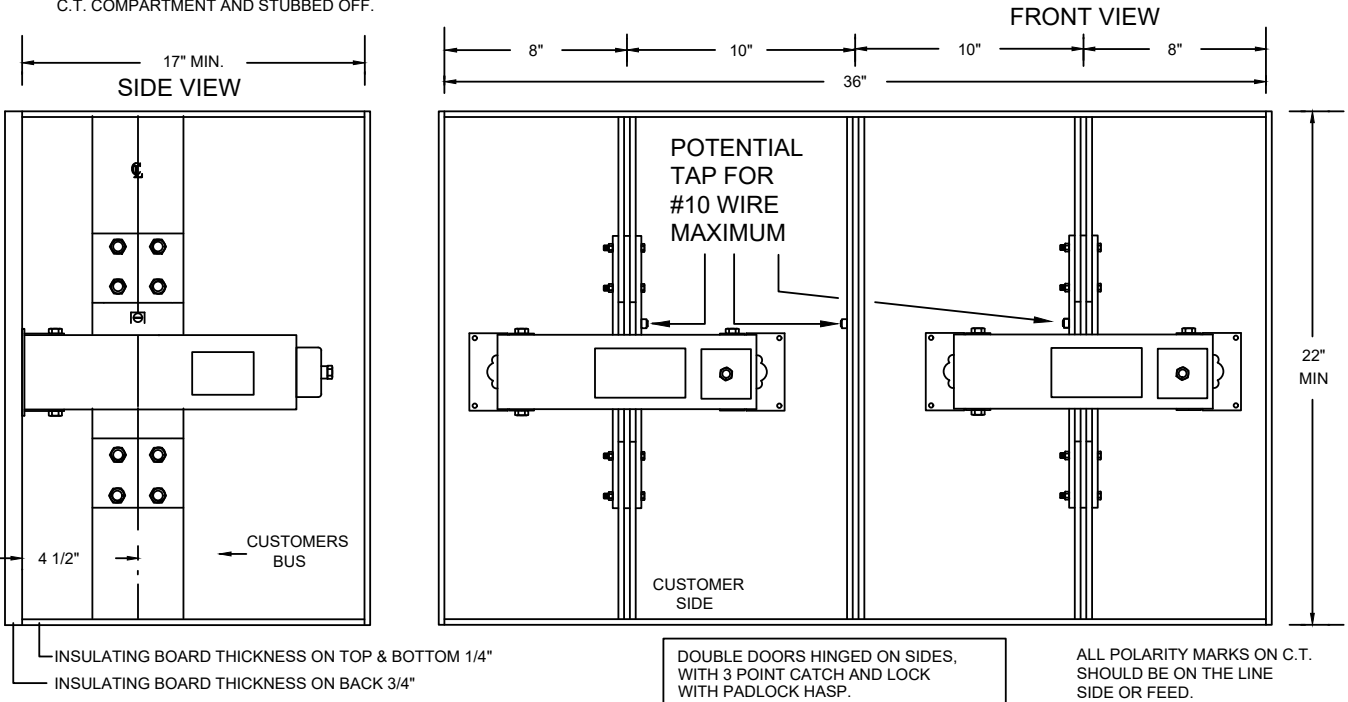

ALL POLARITY MARKS ON C.T. SHOULD BE ON THE LINE SIDE OR FEED.

480V POTENTIAL TRANSFORMER
ENCLOSURE

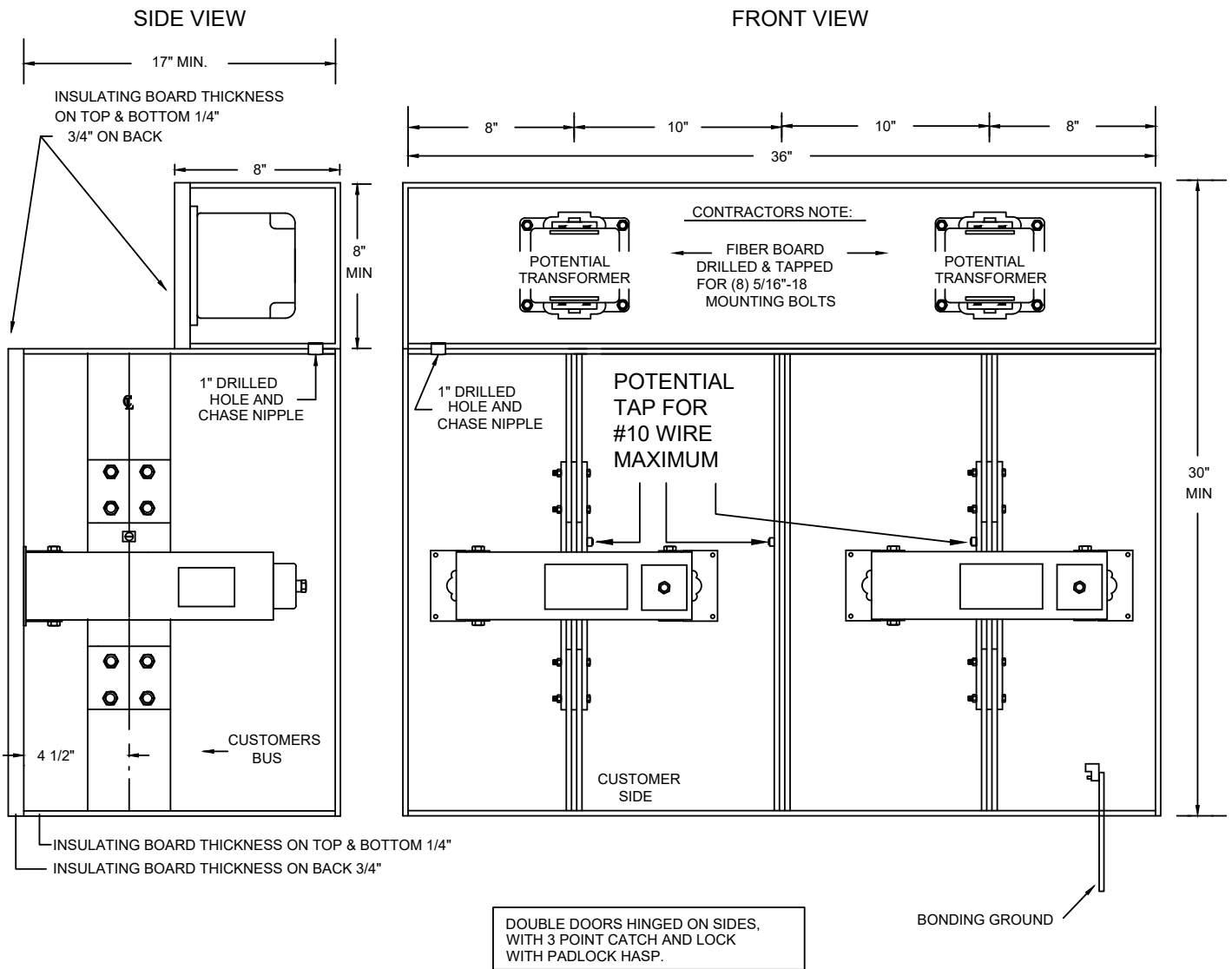

NOTE: SWITCHGEAR METERING IS POSSIBLE WHEN PADMOUNT & CABINET MOUNTED METERING IS IMPOSSIBLE (KU ONLY)

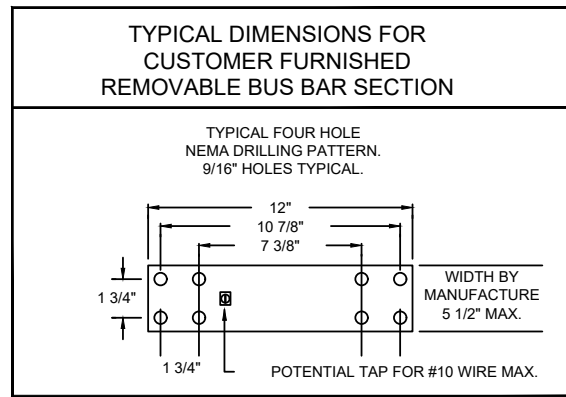
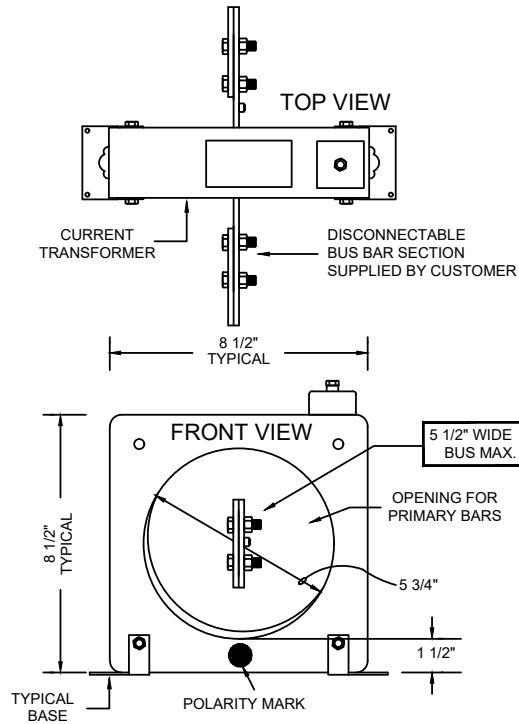

WINDOW TYPE CURRENT TRANSFORMER INSTALLATION

METERING COMPARTMENT FOR SWITCH GEAR

METER BASE TO BE GROUNDED TO SYSTEM GROUND WITH MINIMUM #6 COPPER

NOTES:
DIMENSIONS AS NOTED ARE MINIMUM STANDARDS FOR C.T. SEPARATION. DISTANCE BETWEEN LIVE PARTS SHOULD NOT BE LESS THAN 2".

CONTRACTORS ARE REQUESTED TO CALL T & D DESIGN DEPARTMENT BEFORE PROCEEDING WITH SAME.

1" CONDUIT TO BE INSTALLED FROM METER BASE INTO C.T. COMPARTMENT AND STUBBED OFF.

CURRENT TRANSFORMERS TO BE FURNISHED BY UTILITY.

COPPER OR ALUMINUM BUS BAR CAPACITY AS REQUIRED.

ALL POLARITY MARKS ON C.T. SHOULD BE FACING LINE SIDE OR FEED SIDE.

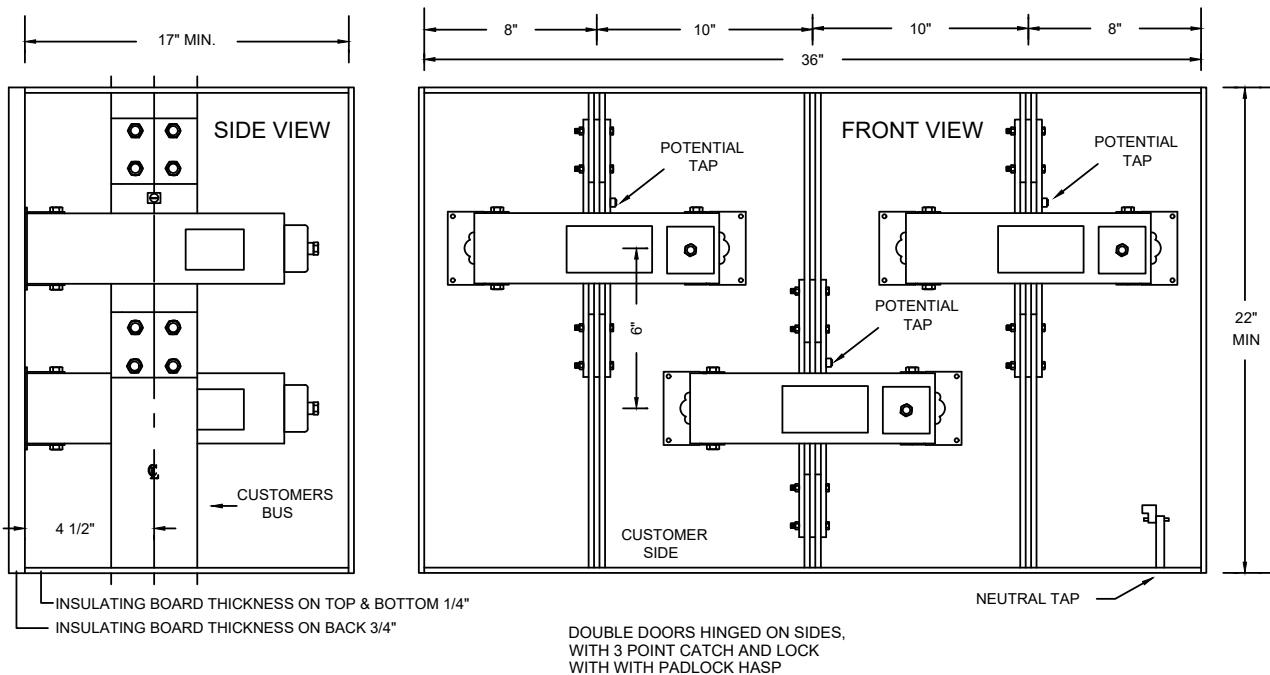

The utility's service representative will make the final determination on the location of the meter base when transformer mounted metering equipment is approved.

General

The standard metering arrangement for large services requires both a meter base and a Customer provided compartment to house instrument transformers (generally Current Transformers (C.T.'s)). Under special conditions when service is provided underground directly from a padmount transformer, the metering transformers can be located inside the secondary compartment of the transformer eliminating the need for a separate CT compartment. Installations with multiple customers not suitable for transformer mounted metering (KU only).

1. All transformer mounted C.T.'s installations must be pre-approved by the utility.
2. Service must be provided directly from a padmount transformer that will never be expected to provide service to more than a single customer and the transformer is not to be used to serve auxiliary loads like fire protection equipment or utility provided lighting.
3. A meter base can be located near (2'-0" min. or 30'-0" max.) the padmount transformer in a secure, accessible location on private property. Typical locations for the meter base will be on a customer provided support adjacent to the transformer or on the wing wall of a fire containment enclosure if required. Other locations as determined by the Company's service representative may also be approved.

Customer Responsibilities

The customer is responsible for providing the transformer pad, trenching and backfill, conduit, meter stand and meter stand grounding and service cables. Utility provided meter base to be installed by Customer. All material to be installed in conformance with utility standards and subject to the approval of the utility.

Utility Installed Items

The utility provides the padmount transformer, transformer grounding, service connectors, metering transformers and associated wiring and the electric meter. The utility will connect the customer's service and grounding cables inside the transformer once all the requirements for service have been met.

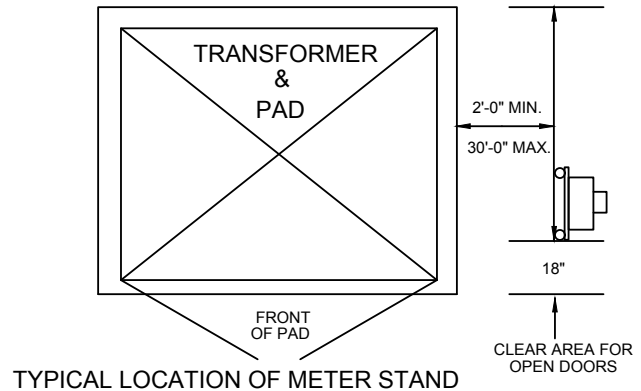
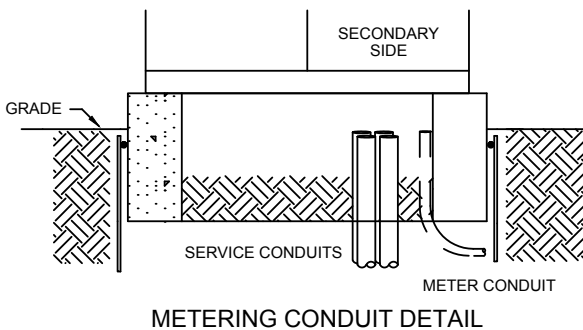
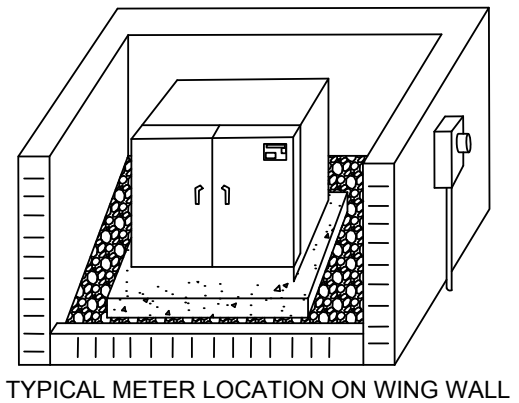
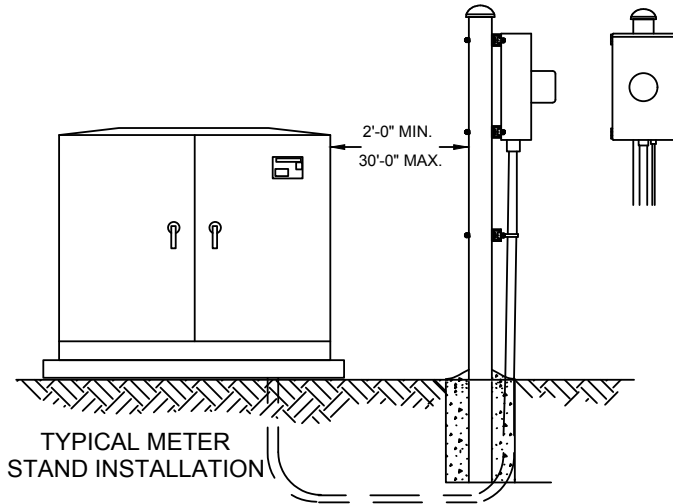

(SEE SHEET 2 OF THIS STANDARD FOR COMPLETE CONSTRUCTION DETAILS.)

The utility's service representative will make the final determination on the location of the meter base when transformer mounted metering equipment is approved.

Conduit Notes:

Meter wiring conduit to be a minimum of 1-1/2" Schedule 80 PVC or rigid metal. Ground lead conduit to be a 1/2" Schedule 80 PVC or rigid metal. A pulling tape should be pre-installed in the 1-1/2" conduit.

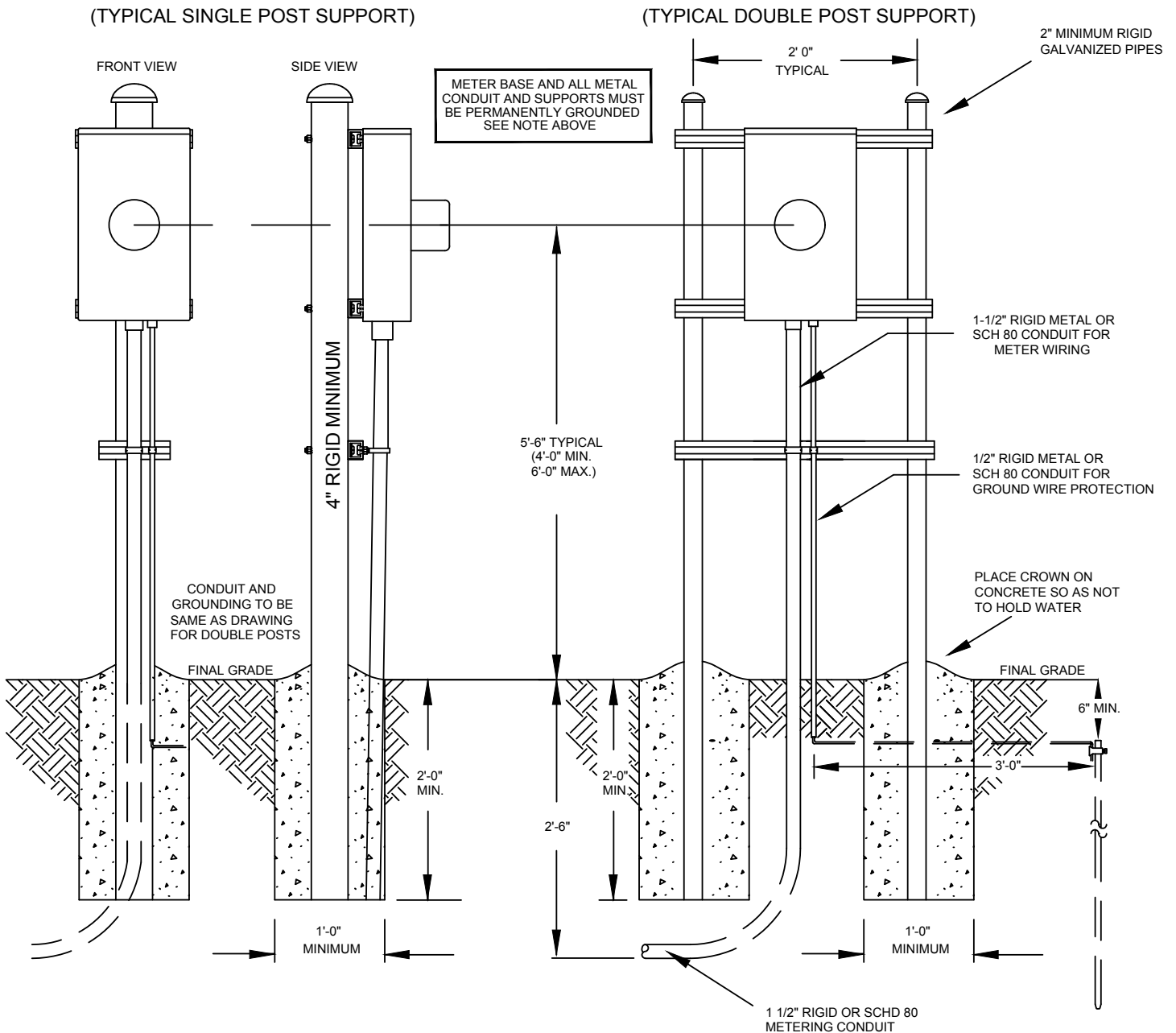

TYPICAL 120/240V, 1Ø, 3W, 400 AMP METER
BASE WITH CLASS 320 METER

NOTE:

1. The meter socket enclosure shall not be used as an auxiliary gutter or junction box.

TYPICAL METER INSTALLATION FOR
OVERHEAD SERVICE 1 OR 2 CABLES
PER PHASE

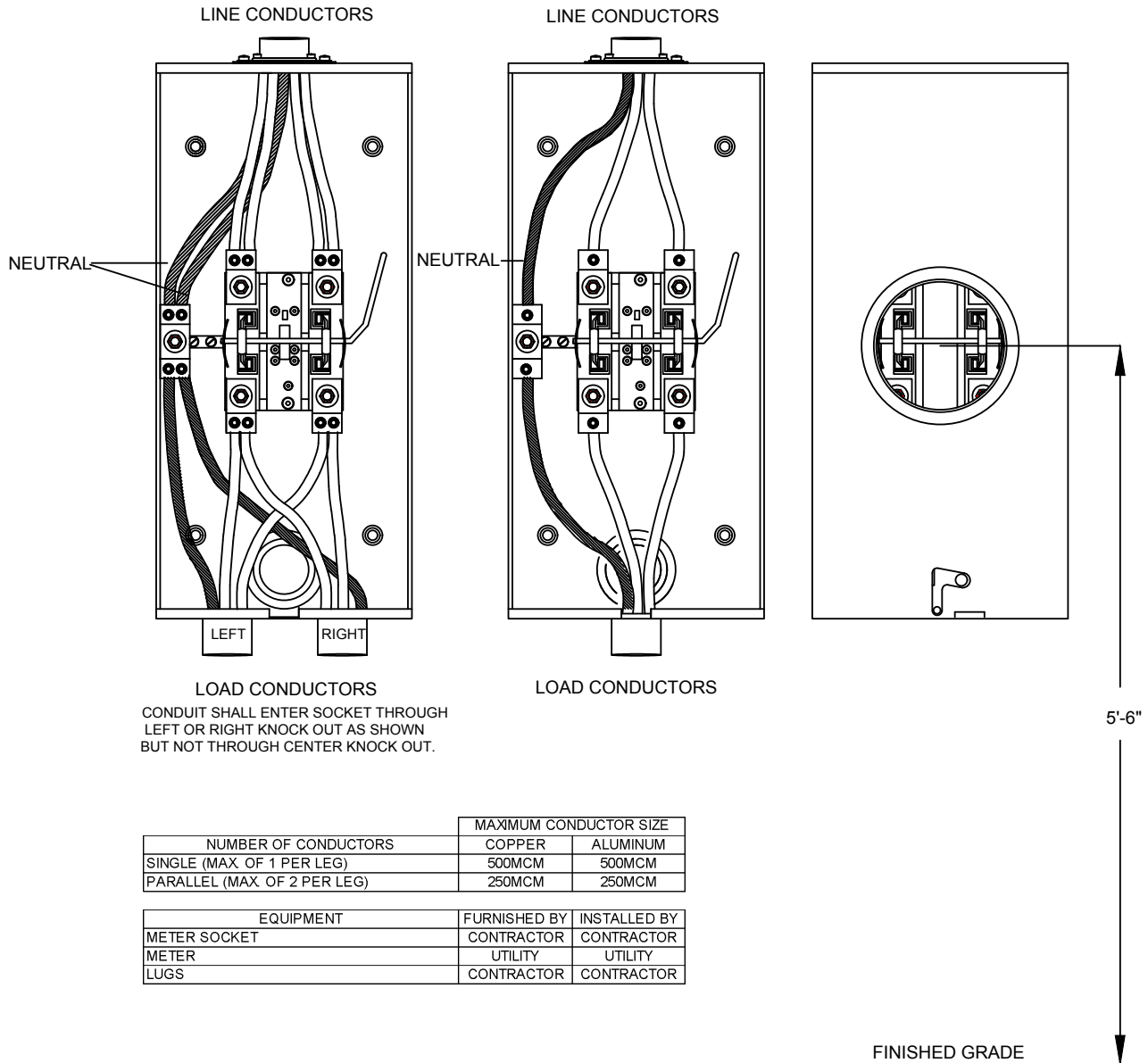

NUMBER OF CONDUCTORS	MAXIMUM CONDUCTOR SIZE	
	COPPER	ALUMINUM
SINGLE (MAX. OF 1 PER LEG)	500MCM	500MCM
PARALLEL (MAX. OF 2 PER LEG)	250MCM	250MCM

EQUIPMENT	FURNISHED BY	INSTALLED BY
METER SOCKET	CONTRACTOR	CONTRACTOR
METER	UTILITY	UTILITY
LUGS	CONTRACTOR	CONTRACTOR

CONTRACTOR NOTES:

- Contractor shall install equipment at the location designated by LG&E/KU Service Locators or Meter Department Supervisors.
- The installation must be acceptable to LG&E/KU before the service is energized.
- Contractors to Supply and Install Lugs for Meter Base.

ALTERNATE BASE NOT PROVIDED BUT, ACCEPTABLE TO BOTH UTILITIES

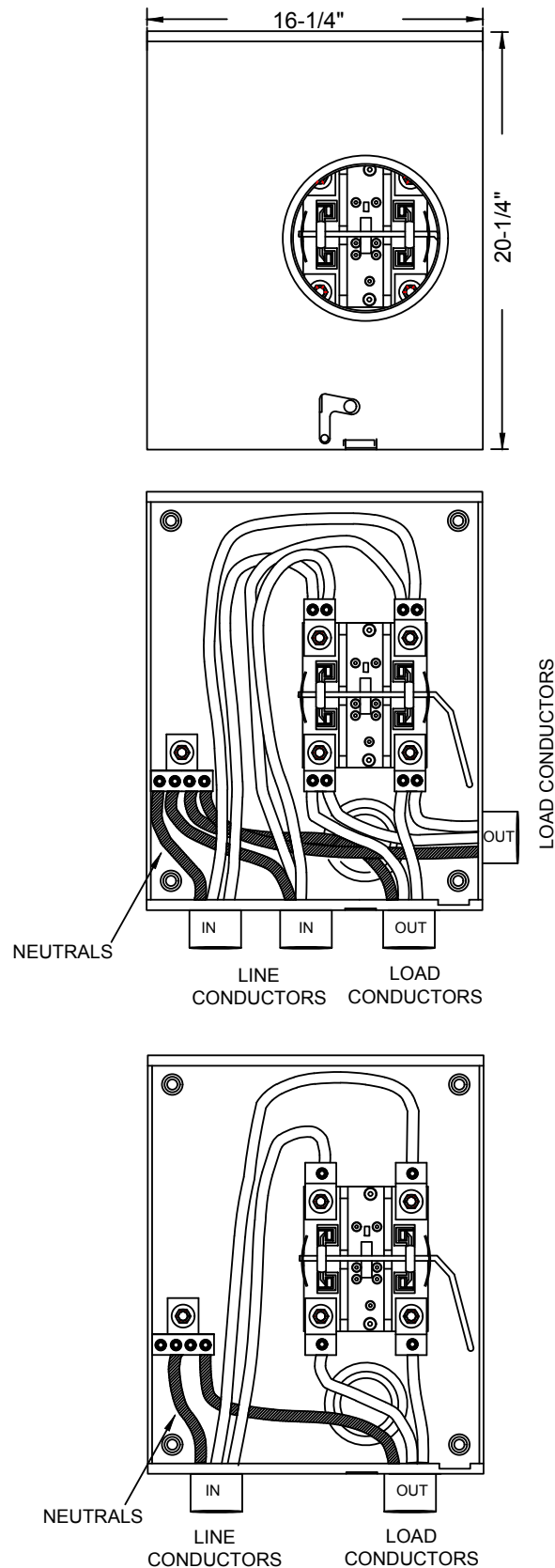

GENERAL NOTES:

- GROUND CLEARANCE SHOULD EXCEED NESC MINIMUMS TO THE EXTENT PRACTICAL TO ENSURE COMPLIANCE UNDER ALL LOADING CONDITIONS THROUGHOUT THE LIFE OF THE INSTALLATION. **SEE STANDARD 02 10 10** FOR NESC GROUND CLEARANCE REQUIREMENTS. SERVICE LINES NOT ENGINEERED AND SAGGED DURING INSTALLATION SHOULD NOT EXCEED 100' IN LENGTH AND MEASURED GROUND CLEARANCE SHOULD EXCEED NESC REQUIREMENTS AT ALL LOCATIONS IN THE SPAN BY A MINIMUM OF 12 INCHES.
- CUSTOMER'S FACILITIES TO BE INSTALLED IN ACCORDANCE WITH ALL NATIONAL, STATE AND LOCAL CODES OR REGULATIONS.
- UTILITY TO PROVIDE SERVICE DROP, ATTACHMENT CLAMP, SERVICE CONNECTORS AND METER. ALL OTHER MATERIALS INCLUDING METER BASE TO BE PROVIDED AND INSTALLED BY CUSTOMER.
- GROUNDING/BONDING
 - KU** - GROUNDING ELECTRODE CONDUCTOR MAY BE BONDED TO THE GROUNDED SERVICE CONDUCTOR WITHIN THE METER BASE OR INSIDE THE SERVICE PANEL AS ALLOWED BY LOCAL JURISDICTIONAL AUTHORITY.
 - LG&E** - GROUNDING ELECTRODE CONDUCTOR MUST BE BONDED WITHIN THE SERVICE PANEL AND NOT IN THE METER BASE AS REQUIRED BY LOCAL JURISDICTIONAL AUTHORITIES.

OVERHEAD SERVICE
UNDER ROOF ATTACHMENT

NOTES:

- CUSTOMER TO PROVIDE SUITABLE ATTACHMENT POINT. LOCATION AND HEIGHT OF POINT FOR ATTACHMENT OF SERVICE CONDUCTORS MUST BE SPECIFIED AND APPROVED BY UTILITY. ACCEPTABLE POINTS OF ATTACHMENT ARE THE BUILDING STUDS, MORTAR JOINTS AND RAFTERS. UNACCEPTABLE POINTS OF ATTILITY ARE THE OUTSIDE TRIM BOARD, INSIDE TRIM BOARD, SOFFIT BOARD, FASCIA BOARD, FIRE WALLS, PARAPET WALLS OR CHIMNEYS. (OUTSIDE TRIM BOARD, INSIDE TRIM BOARD AND SOFFIT BOARDS MAY BE ATTACHED TO IF ADEQUATELY REINFORCED.)
- POINT OF ATTACHMENT SHOULD NOT BE FARTHER THAN 2' FROM THE WEATHERHEAD AND INSTALLED BY THE ELECTRICIAN TO TERMINATE UTILITY SERVICE.

ENERGIZED SERVICE DROP CONDUCTORS, INCLUDING SPLICES AND TAPS, SHALL BE INSULATED OR COVERED. FOR SERVICES UP TO 750V, SERVICE CAN CONSIST OF COVERED OR INSULATED SINGLE CONDUCTORS OR MULTIPLEX SERVICE CABLES.

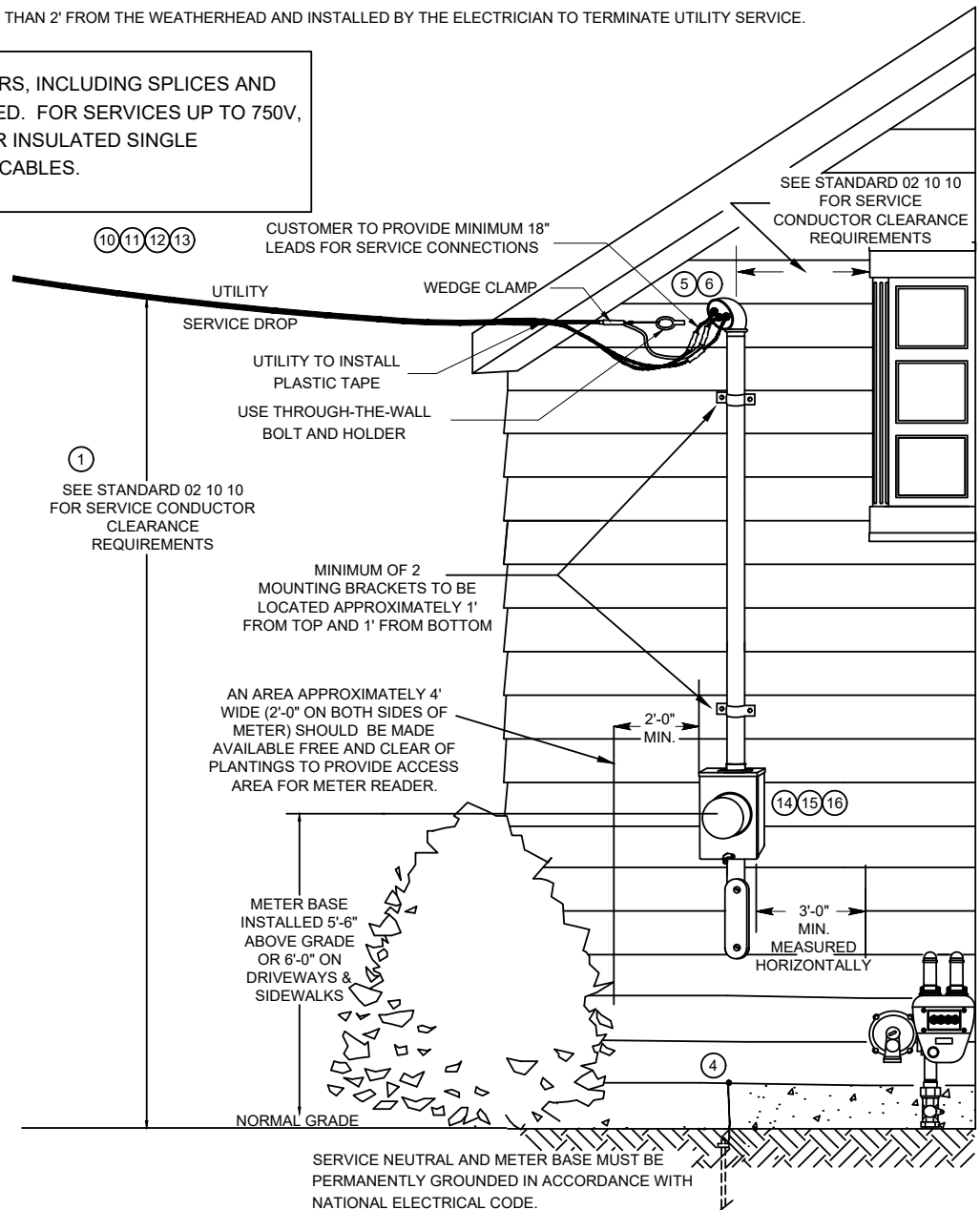

OVERHEAD SERVICE
ABOVE ROOF ATTACHMENT

FOR GENERAL NOTES SEE PAGE 1

NOTES:

7. A SERVICE MAST IS REQUIRED WHEN IT IS NOT POSSIBLE TO MAINTAIN 12' CLEARANCE FROM FINISHED GRADE TO THE LOWEST POINT OF THE CONDUCTOR INCLUDING THE DRIP LOOP UNDER ALL LOADING CONDITIONS THROUGHOUT THE LIFE OF THE INSTALLATION. VERTICAL CLEARANCE OF CONDUCTOR TO ROOF SURFACE DEPENDS ON THE SLOPE OF THE ROOF. SEE NEC 230-24(A).
8. MINIMUM 2" RIGID STEEL CONDUIT TO BE USED FOR RISERS THROUGH THE ROOF ON 100A SERVICES. A MINIMUM OF 2-1/2" WILL BE REQUIRED FOR 200A SERVICES UNLESS APPROVED BY THE UTILITY. A MINIMUM OF 3" WILL BE REQUIRED FOR 400A SERVICES UNLESS APPROVED BY THE UTILITY. FOR SERVICES LARGER THAN 400A, SEEK GUIDANCE FROM THE UTILITY. UTILITY MAY REQUIRE ADDITIONAL GUYING, STRAPPING AND/OR LARGER CONDUIT SIZE WHERE SERVICE DROPS ARE LONG OR LARGER CONDUCTORS ARE USED. RISER TO BE SECURELY BLOCKED AND STRAPPED IN RAFTERS AND A MINIMUM OF TWO CONDUIT STRAPS ARE REQUIRED BELOW THE SOFFIT.
9. LOCATION AND HEIGHT OF POINT FOR ATTACHMENT OF SERVICE CONDUCTORS MUST BE SPECIFIED AND APPROVED BY UTILITY.

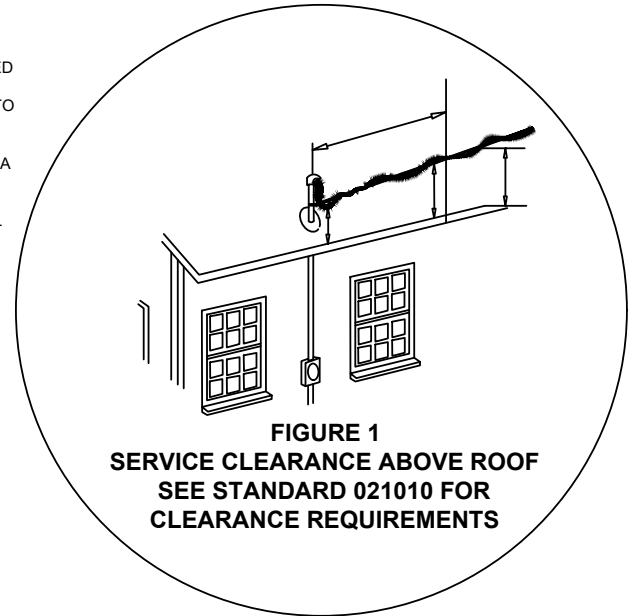
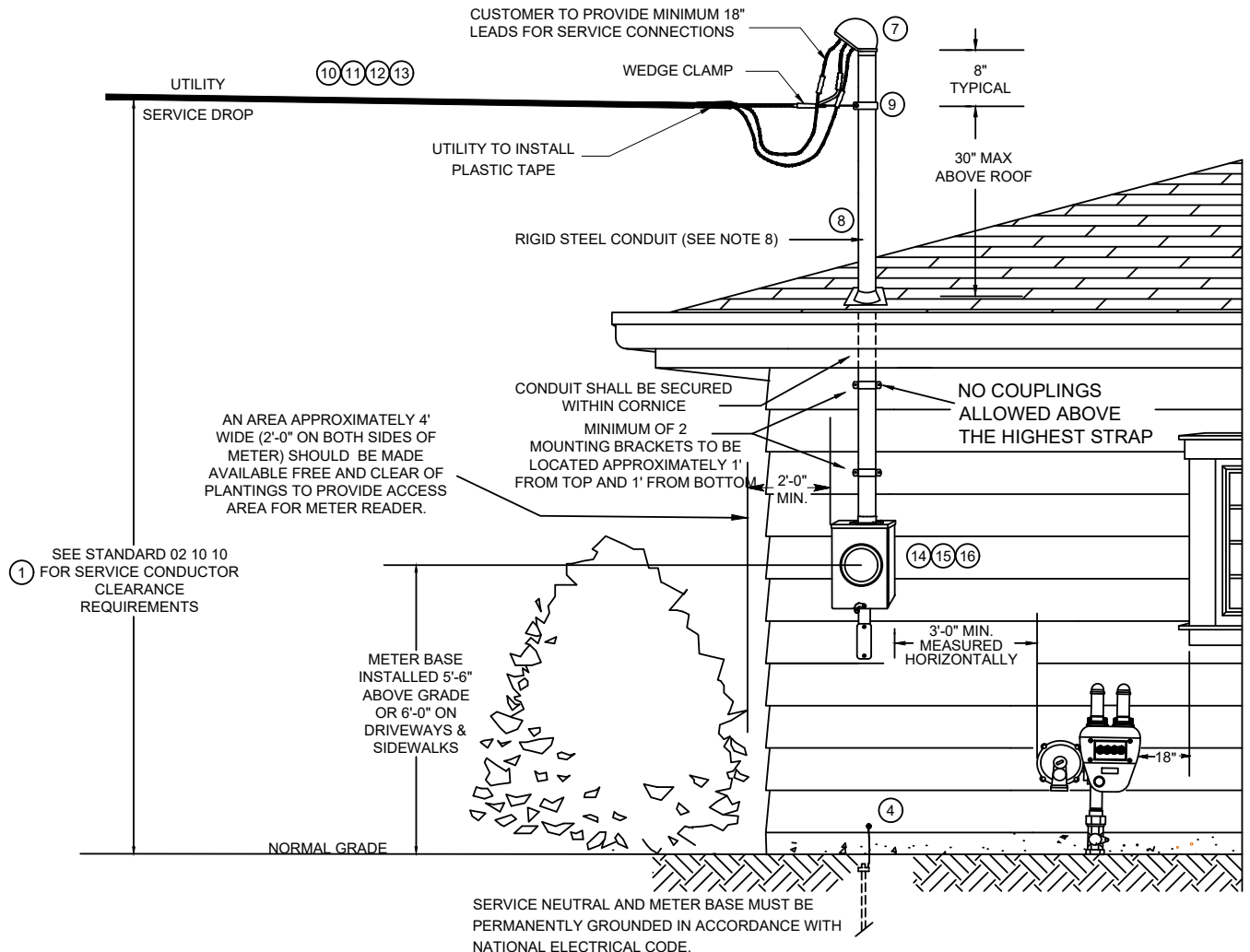

FIGURE 1
SERVICE CLEARANCE ABOVE ROOF
SEE STANDARD 021010 FOR
CLEARANCE REQUIREMENTS

ENERGIZED SERVICE DROP CONDUCTORS, INCLUDING SPLICES AND TAPS, SHALL BE INSULATED OR COVERED. FOR SERVICES UP TO 750V, SERVICE CAN CONSIST OF COVERED OR INSULATED SINGLE CONDUCTORS OR MULTIPLEX SERVICE CABLES.



NOTES:

10.

TYPICAL OVERHEAD TRIPLEX CONDUCTOR FOR 1Ø SERVICE*			
IIN#	DESCRIPTION	SERVICE	MAX. LENGTH
3032815	TWO INSULATED #2 AL AND ONE BARE #2 ACSR NEUTRAL	100 AMPS	150 FEET
3032814	TWO INSULATED 1/0 AL AND ONE BARE 1/0 ACSR NEUTRAL	200 AMPS	100 FEET
3028737	TWO INSULATED 4/0 AL AND ONE BARE 4/0 ACSR NEUTRAL	400 AMPS	100 FEET

11.

TYPICAL OVERHEAD QUADRUPLIX CONDUCTOR FOR 3Ø SERVICE*			
IIN#	DESCRIPTION	SERVICE	MAX. LENGTH
1197686	THREE INSULATED 1/0 AL AND ONE BARE 1/0 ACSR NEUTRAL	200 AMPS	75 FEET
1197694	THREE INSULATED 4/0 AL AND ONE BARE 4/0 ACSR NEUTRAL	400 AMPS	75 FEET

12. A LEGACY 397 SERVICE DROP SHOULD NEVER BE SPLICED
13. FOR SERVICE GREATER THAN 400 AMPS, THE SERVICE CONDUCTOR SHALL BE SPECIFIED BY THE UTILITY'S LOCAL ENGINEER, BASED ON A CUSTOMER PROVIDED LOAD DATA.
14. INSTRUMENT RATED METERING IS REQUIRED FOR ALL SERVICES ABOVE 400 AMPS. SEE STANDARDS 81 10 XX FOR DETAILS.
15. 480 VOLT SERVICE NOT IN EXCESS OF 200A MUST UTILIZE SELF-CONTAINED METERING USING A DISCONNECT SWITCH AHEAD OF THE METER (STANDARD 81 20 12).
16. 480 VOLT SERVICE GREATER THAN 200 AMPS MUST UTILIZE INSTRUMENT RATED METERING (STANDARDS 81 10 XX).

TYPICAL 1Ø RINGLESS METER BASE

APPROVED CUSTOMER PROVIDED
RINGLESS METER BASE

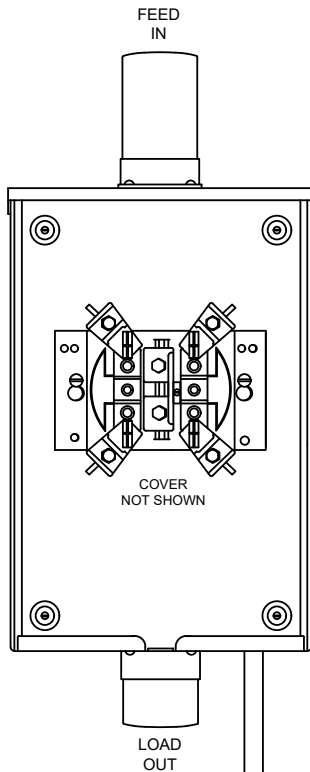

TYPICAL 3Ø RINGLESS METER BASE

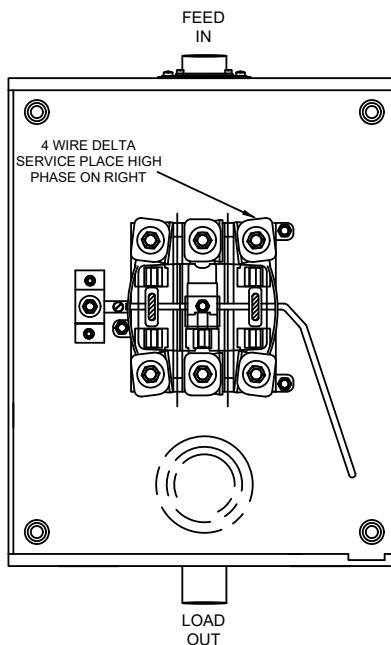

TYPICAL 480V RINGLESS METER BASE

SEE STANDARD 812012 FOR 480V
DISCONNECT REQUIREMENTS

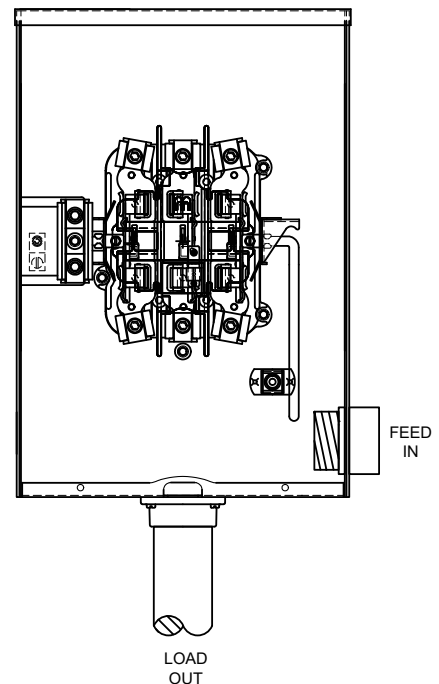

FOR 120/208 VOLT 1Ø SERVICE, THE CUSTOMER PROVIDED METER BASE SHALL BE A FIFTH LUG DESIGN.

METER BASES MUST BE GROUNDED PER NEC CODE

NOTES:

1. THIS STANDARD DETAILS THE NUMBERING OF ELECTRIC MULTI-METER INSTALLATIONS.
2. LG&E/KU MUST VERIFY THAT SERVICES HAVE BEEN MARKED WITH CORRECT UNIT NUMBER BY ELECTRICIAN.
3. SERVICE POINTS SHOULD BE PERMANENTLY MARKED WITH THE UNIT NUMBER ON THE INSIDE OF THE METER BASE NEXT TO THE BLOCK USING PERMANENT MARKER OR PAINT PEN.
4. SERVICES ARE TO BE LABELED USING 1" POLYMER DIGITS CONSISTING OF THE UNIT NUMBER FOR THAT SERVICE. NUMBERS MUST MATCH THE NUMBERING ON THE UNIT.
5. 1" POLYMER DIGITS ARE TO BE PLACED ABOVE EACH BREAKER USING SILICONE ADHESIVE. FOR METER BASE WHERE BREAKERS ARE LOCATED BELOW THE METER UNIT NUMBER SHOULD BE PLACED NEXT TO THE BREAKER.
6. UNIT NUMBERS ARE NOT TO BE PLACED ON THE METER BASE LIDS AS TO AVOID THE SWITCHING OF LIDS.

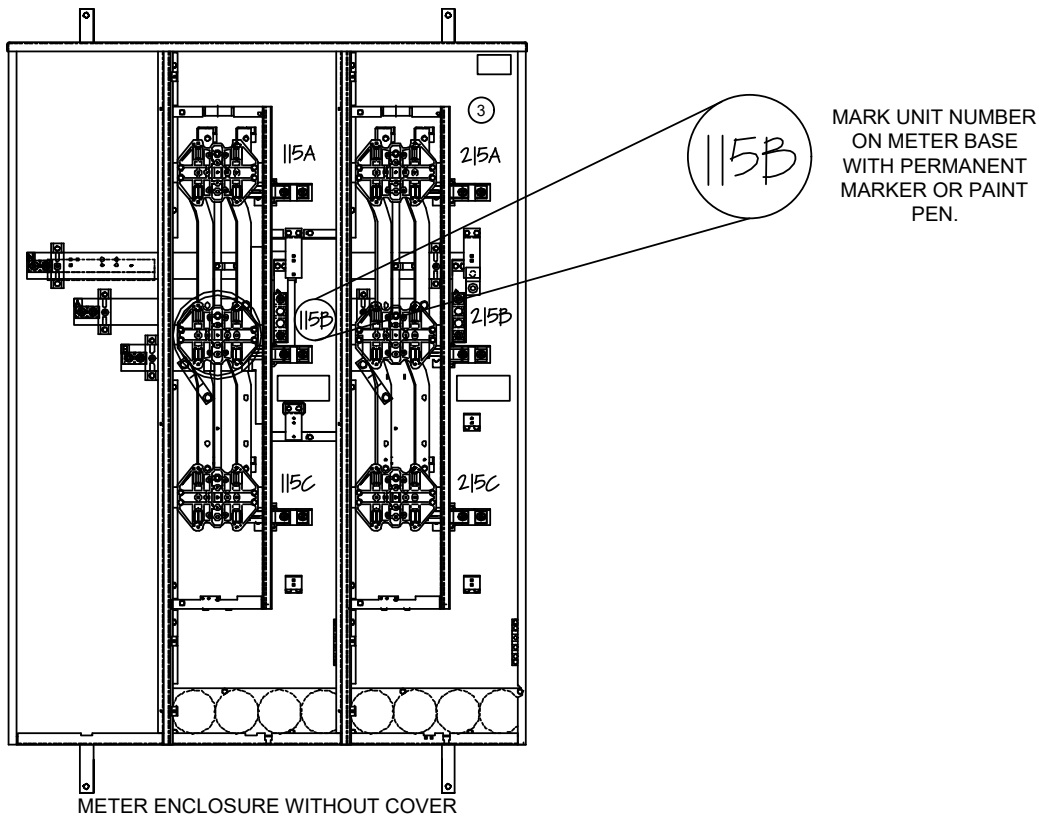
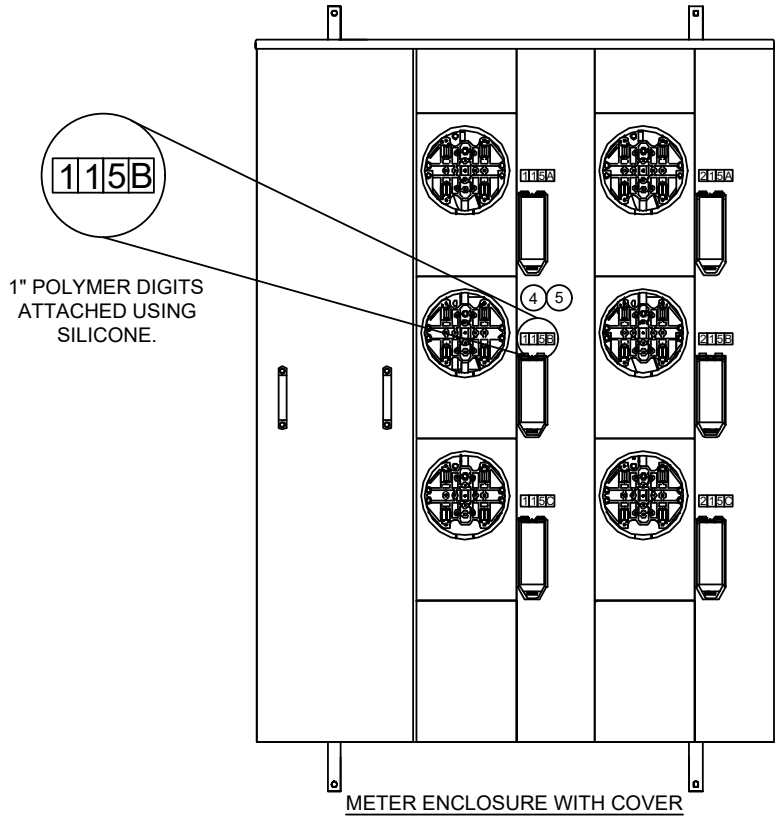

NOTES:

1. GROUND CLEARANCE SHOULD EXCEED NESC MINIMUMS TO THE EXTENT PRACTICAL TO ENSURE COMPLIANCE UNDER ALL LOADING CONDITIONS THROUGHOUT THE LIFE OF THE INSTALLATION. **SEE STANDARD 02 10 10** FOR NESC CLEARANCE REQUIREMENTS. SERVICE LINES NOT ENGINEERED AND SAGGED DURING INSTALLATION SHOULD NOT EXCEED 100' IN LENGTH AND MEASURED GROUND CLEARANCE SHOULD EXCEED NESC REQUIREMENTS AT ALL LOCATIONS IN THE SPAN BY A MINIMUM OF 12 INCHES.
2. CUSTOMER'S FACILITIES TO BE INSTALLED IN ACCORDANCE WITH ALL NATIONAL, STATE AND LOCAL CODES OR REGULATIONS.
3. LOCATION AND HEIGHT OF POINT FOR ATTACHMENT OF SERVICE CONDUCTORS MUST BE SPECIFIED AND APPROVED BY UTILITY.
4. ATTACHMENT MUST BE ADEQUATE TO PREVENT DAMAGE TO CUSTOMER'S PROPERTY AT MAXIMUM TENSION. SERVICE ENTRANCE HEAD SHOULD BE ABOVE AND NOT FARTHER THAN 24" FROM POINT OF SERVICE ATTACHMENT.
5. UTILITY TO PROVIDE SERVICE DROP, ATTACHMENT CLAMP, SERVICE CONNECTORS AND METER. ALL OTHER MATERIALS INCLUDING METER BASE TO BE PROVIDED AND INSTALLED BY CUSTOMER.
6. NOTIFY UTILITY FOR METER INSTALLATION.
7. MOUNTING PROVISIONS SPECIFIED BY UTILITY. MOUNTING BRACKET FURNISHED AND INSTALLED BY CUSTOMER.
8. WEATHERHEAD(S) TO BE LOCATED AT OR ABOVE THE POINT OF SERVICE ATTACHMENT. PROVIDE MINIMUM 18" LEADS FOR SERVICE CONNECTIONS.
9. GANG METER BASE WITH MAIN DISCONNECT OR SEPARATE INDIVIDUAL DISCONNECTS FOR EACH TENANT TO BE FURNISHED BY CUSTOMER. METER BASE TO INCLUDE LOCKING HATCH AND PADLOCK EYE. ALL DISCONNECTS TO BE INSTALLED ON CUSTOMER'S SIDE OF METER.
10. SEE STANDARD# 812003 FOR DETAILS ON LABELING MULTI-FAMILY METERS.

ENERGIZED SERVICE DROP CONDUCTORS, INCLUDING SPLICES AND TAPS, SHALL BE INSULATED OR COVERED. FOR SERVICES UP TO 750V, SERVICE CAN CONSIST OF COVERED OR INSULATED SINGLE CONDUCTORS OR MULTIPLEX SERVICE CABLES. SERVICE ABOVE 750V WILL BE MADE WITH METALLICALLY SHIELDED CABLE.

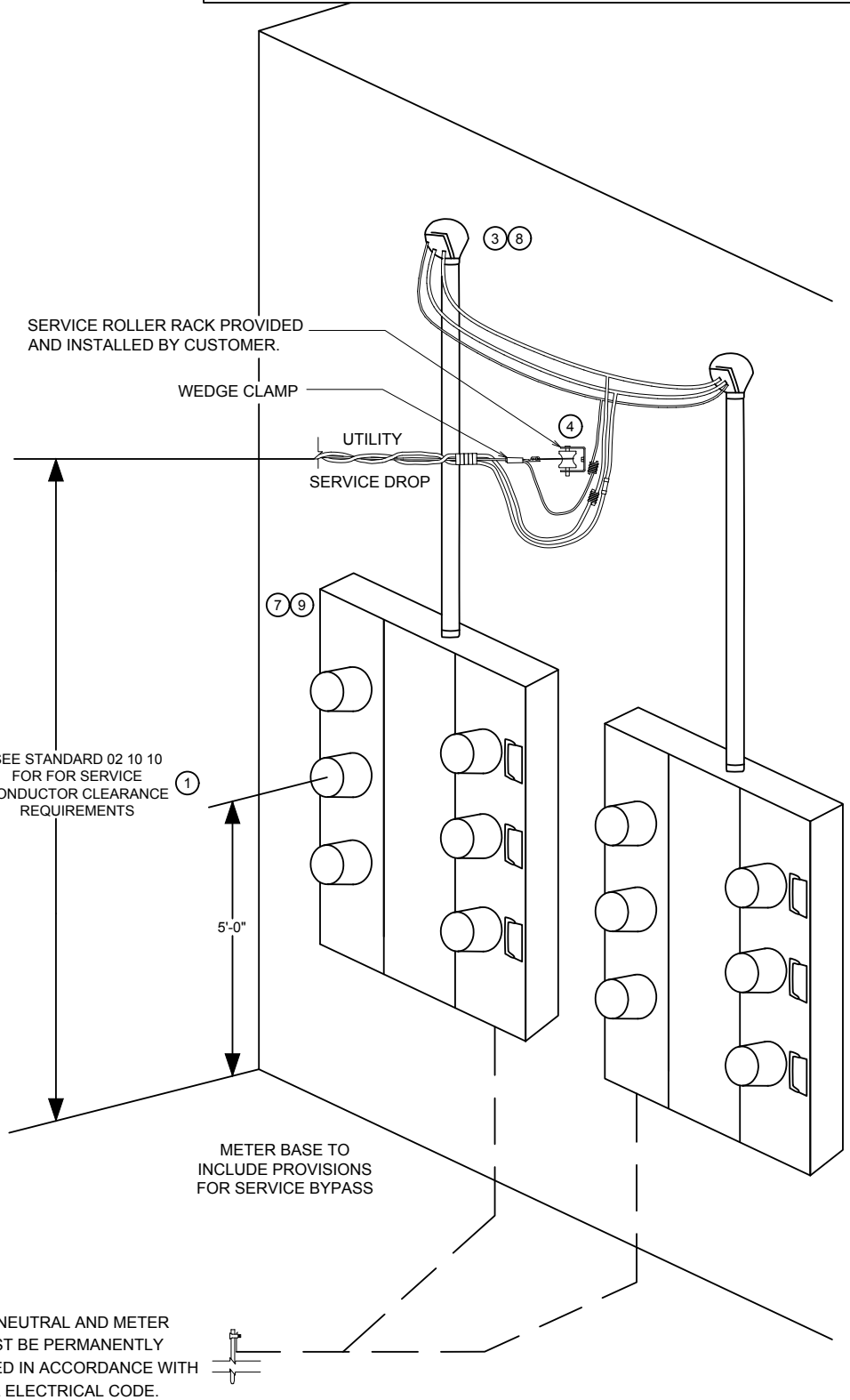

ALL MATERIALS AND WORKMANSHIP SHALL CONFORM WITH THE REQUIREMENTS OF THE ELECTRIC CODE GOVERNING THE LOCALITY OF THIS INSTALLATION AND SHALL BE ACCEPTABLE TO THE AUTHORITY ENFORCING SUCH REGULATIONS. CONTRACTORS ARE REQUESTED TO CALL THE APPROPRIATE DESIGN TECH/LOCATOR FOR THE LOCATION FOR EACH INSTALLATION BEFORE PROCEEDING WITH CONSTRUCTION.

TYPICAL 400A OR BELOW
120/240V 1Ø 3 WIRE
UNDERGROUND SERVICE ENTRANCE

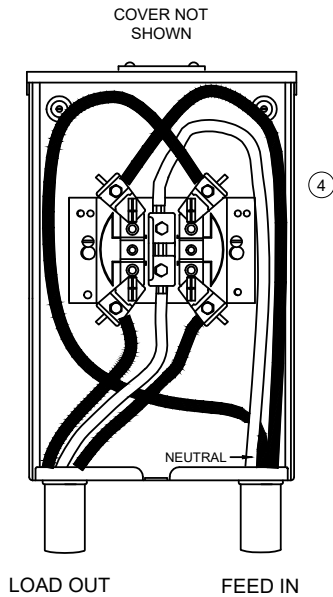

- ① METER BASE CONNECTIONS AND UNDERGROUND WIRE TO BE INSTALLED BY OWNER (LG&E ONLY).
- ② ELECTRICAL NON-METALLIC CONDUIT SHALL BE USED FOR PROTECTION.
- ③ #6 CU. WIRE & GROUNDING CLAMP. 8" X 3/4" DIA. GALVANIZED PIPE FOR GROUND. GROUNDING IS DONE IN PANEL BOX, NOT METER BASE.
- ④ PROVIDE SUFFICIENT WIRE LOOP WITHIN METER BASE TO ALLOW FOR SERVICE LINE SETTLING.

UTILITY POLE
& SECONDARY

SEE 52 01 00 FOR
SERVICE & WIRE SIZE

REFER TO STANDARD DWG. 510403
FOR POLE FRAMING INSTRUCTIONS.

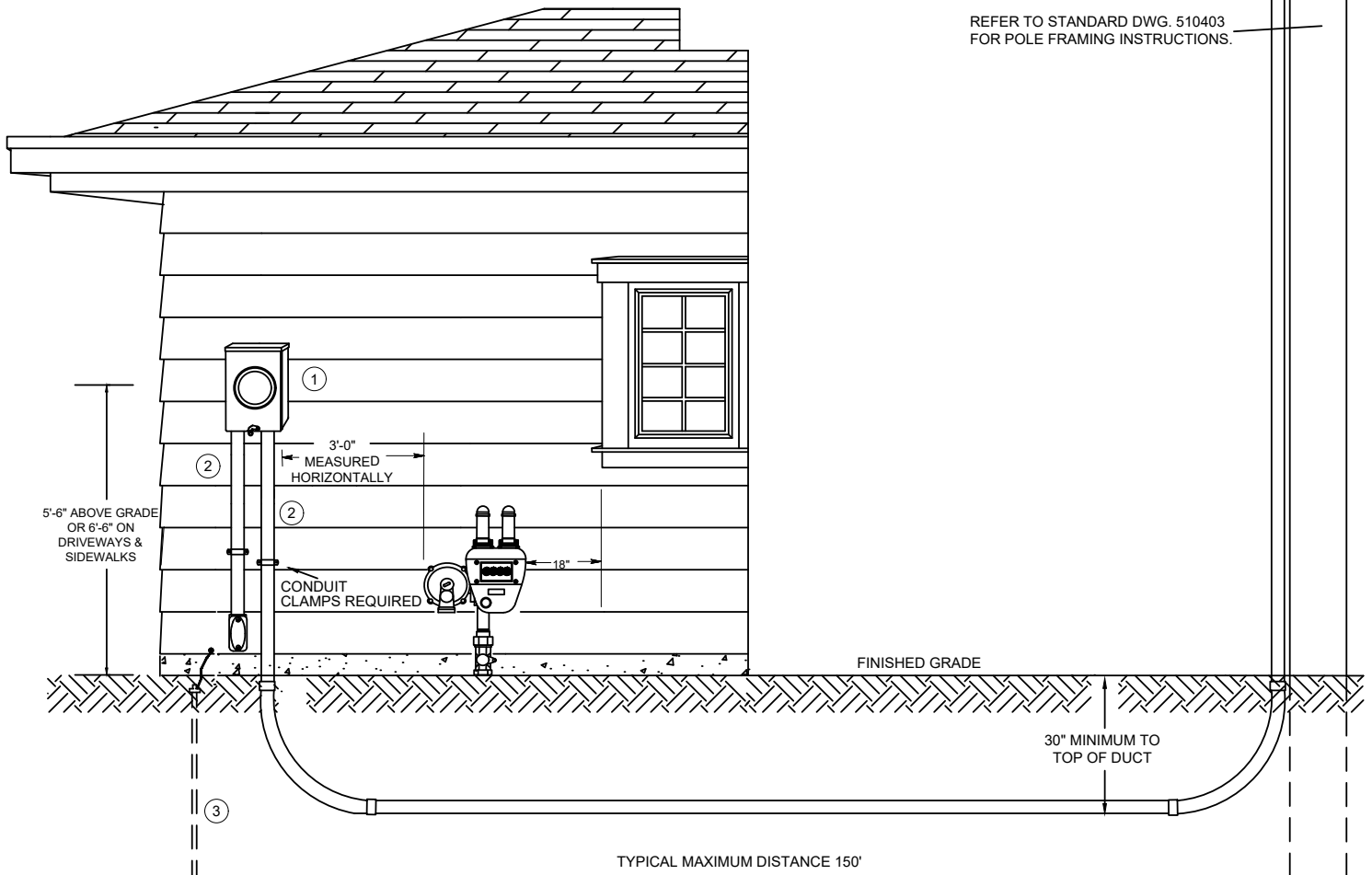

REQUIREMENTS FOR SERVICE

SERVICE CONNECTIONS CANNOT BE MADE UNTIL THE FOLLOWING CONDITIONS HAVE BEEN MET.

1. A RESPONSIBLE PERSON HAS APPLIED FOR SERVICE.
2. UTILITY HAS BEEN NOTIFIED BY THE APPROPRIATE INSPECTION AUTHORITY THAT THE INSTALLATION HAS BEEN INSPECTED AND APPROVED FOR SERVICE.
3. ALL UTILITY REQUIREMENTS FOR SERVICE HAVE BEEN MET AND THE INSTALLATION HAS BEEN ACCEPTED BY LOCAL UTILITY.

MATERIAL AND INSTALLATION

1. UTILITY WILL PROVIDE AND INSTALL THE ELECTRIC METER.
2. CONTRACTOR MUST INSTALL UTILITY APPROVED METER BASE OR APPROVED EQUAL. SEE APPROVAL LIST.
3. ALL OTHER MATERIAL IS TO BE FURNISHED AND INSTALLED BY THE CONTRACTOR IN CONFORMANCE WITH THE NATIONAL ELECTRIC CODE AND THE REQUIREMENTS OF THE INSPECTION AUTHORITY HAVING JURISDICTION.

SHOULD ANY OF THE CONDITIONS REQUIRED FOR SERVICE NOT BE MET, SERVICE WILL NOT BE CONNECTED AND THE UTILITY MAY IMPOSE AN APPROPRIATE CHARGE TO COVER THE COST TO RETURN AND CONNECT THE SERVICE.

THIS STANDARD DRAWING IS INTENDED TO PROVIDE A GUIDE FOR ONE OF VARIOUS ACCEPTABLE CONSTRUCTION DESIGNS. YOUR COMPANY REPRESENTATIVE WILL DETERMINE THE APPROPRIATE CONSTRUCTION DESIGN FOR YOUR SITUATION.

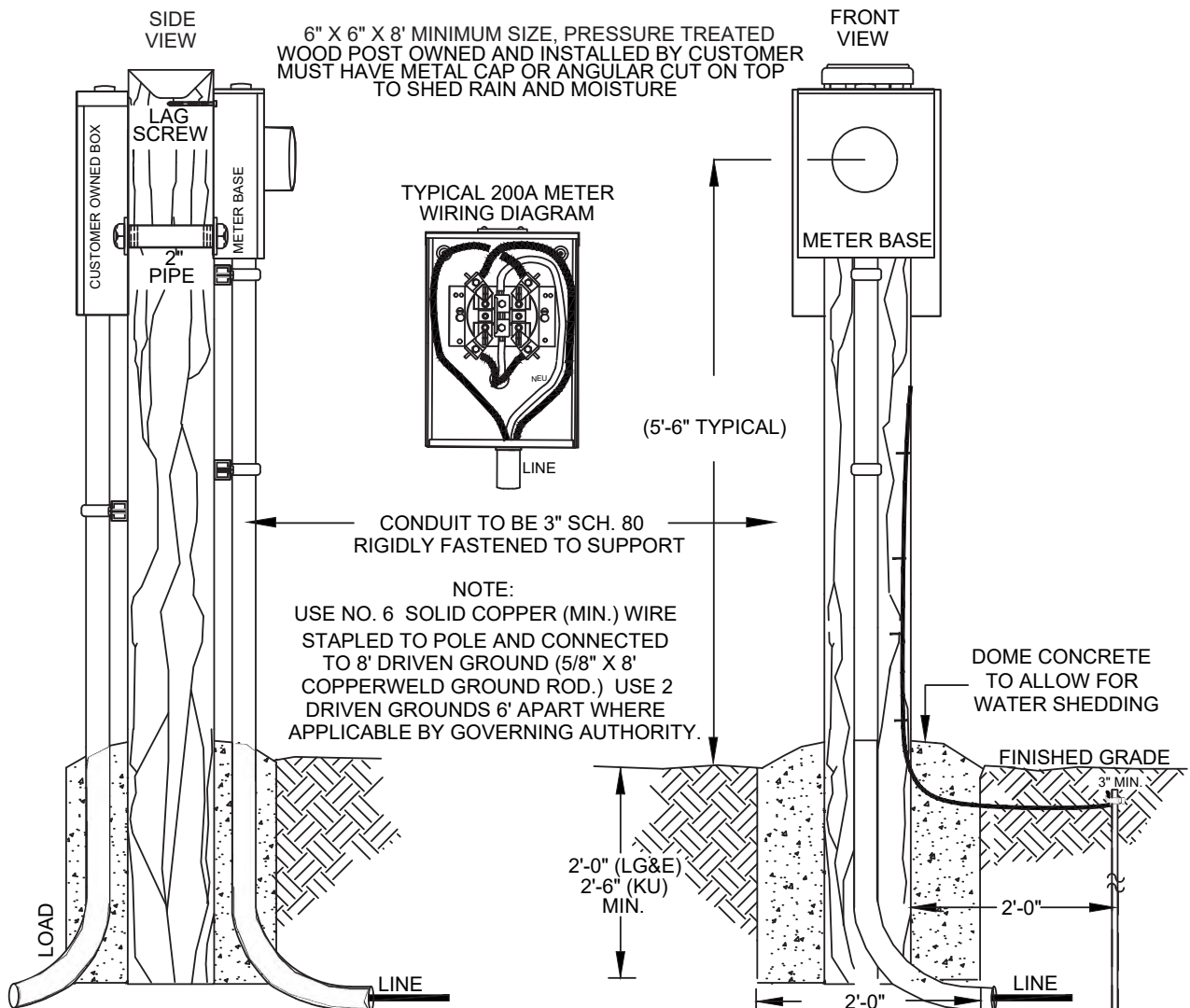

ALTERNATIVE CONSTRUCTION
(TYPICAL DOUBLE POST SUPPORT)

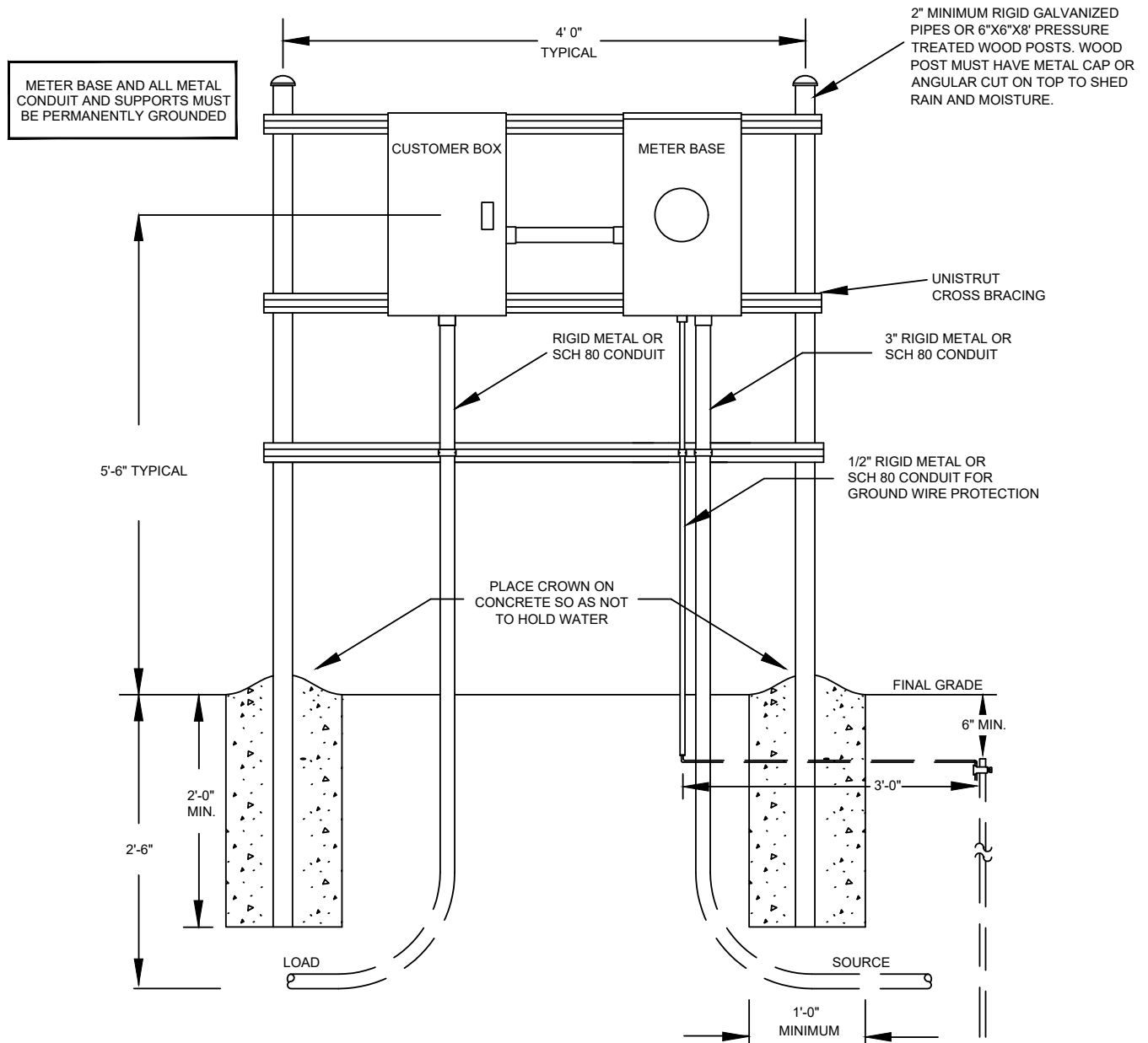

NOTE:

1. THE METER BASE SHOWN IS USED FOR BOTH SINGLE PHASE OVERHEAD AND SINGLE PHASE UNDERGROUND SERVICE.
2. A HUB FOR CONDUIT IS ATTACHED TO THE OVERHEAD METER BASE AT THE TOP. A PLATE IS SUBSTITUTED FOR THE HUB FOR ALL UNDERGROUND SERVICES.
3. TYPICALLY METER BASES ARE INSTALLED 5'-6" FROM CENTER OF METER TO FINISHED GRADE BELOW.
4. MAXIMUM WIRE SIZE FOR THIS 200A METER BASE IS 4/0 ALUM. OR 3/0 CU.
5. THE NEUTRAL USED IN THIS TYPE OF METER WILL BE INSULATED AND CONTINUOUS.
6. METER BASE PROVIDED BY CUSTOMER
7. METER BASES ARE TYPICALLY INSTALLED THREE WAYS.
- A) TOGGLE BOLTS FOR CONCRETE BLOCK.
- B) TAPCON SCREWS FOR BRICK MORTAR.
- C) 2" WOOD SCREWS FOR VINYL SIDING OR WEATHERBOARDING.
8. METER BASE MUST HAVE BYPASS CAPABILITY

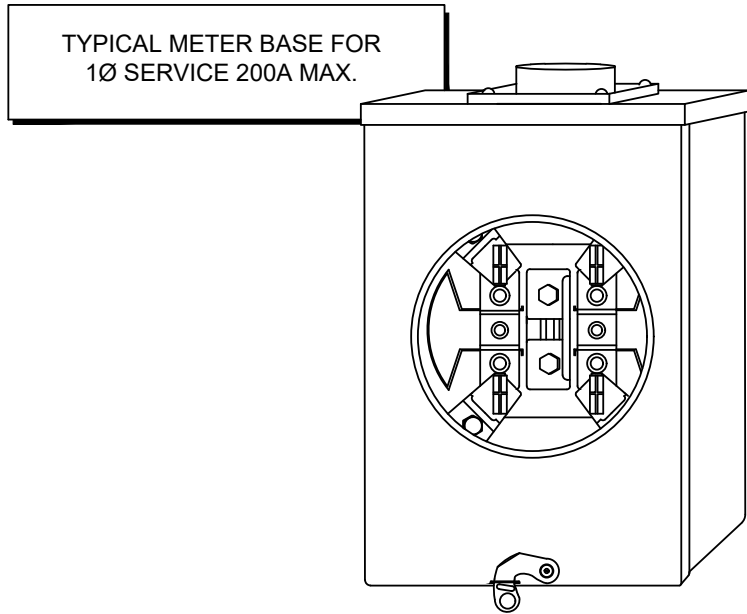

(COVER PLATE PROVIDED WITH BASE)

TYPICAL METER INSTALLATION FOR 1Ø OVERHEAD SERVICE (200A MAXIMUM)

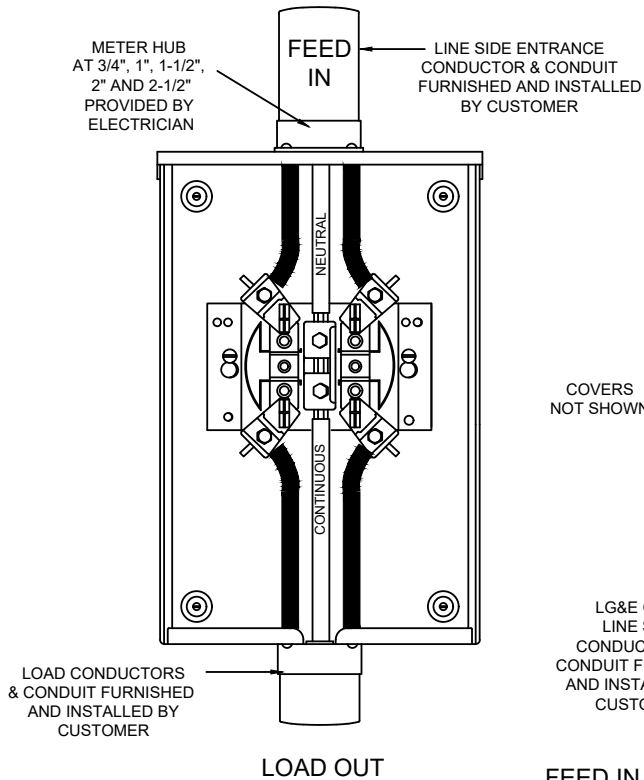

TYPICAL METER INSTALLATION FOR 1Ø UNDERGROUND SERVICE (200A MAXIMUM)

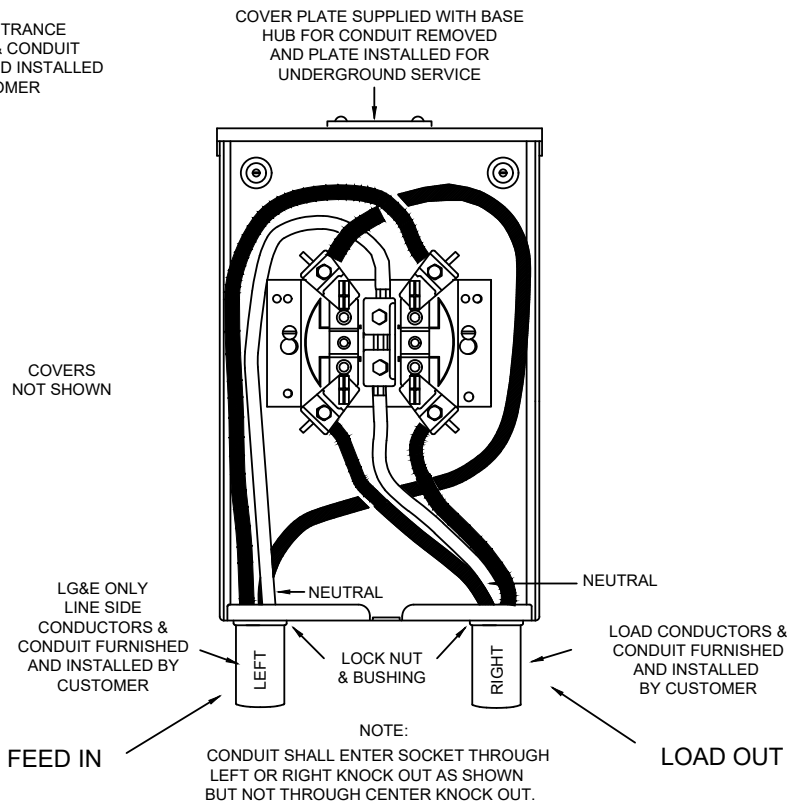

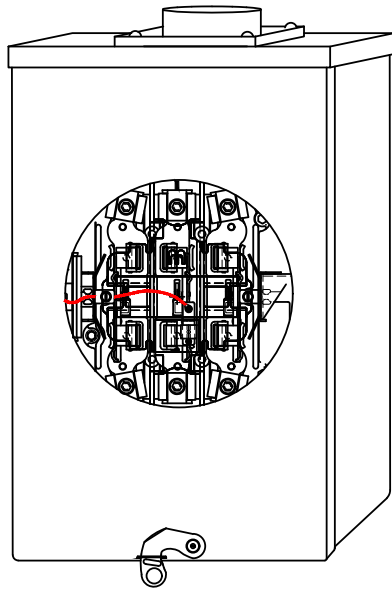

(COVER PLATE PROVIDED WITH BASE)

TYPICAL
SELF-CONTAINED/OVERHEAD METER
SOCKET FOR USE ON 4 WIRE 3Ø
SERVICES. ALL VOLTAGES
UP TO 400 AMP UNDER 300 VOLTS SERVICE

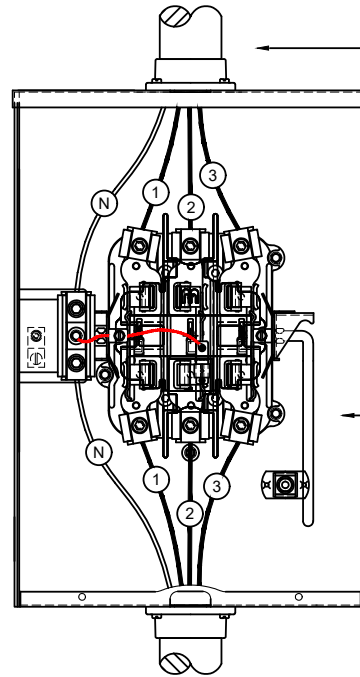

- LINE SIDE ENTRANCE
CONDUCTORS FURNISHED AND
INSTALLED BY CUSTOMER
- PLASTIC PROTECTIVE SHIELD
(NOT SHOWN) MUST BE IN
PLACE
- DELTA 4W HIGH PHASE MUST
BE ON RIGHT HAND SIDE
- BY-PASS LEVER
DO NOT OPERATE UNLESS
METER IS IN PLACE

CUSTOMER SUPPLIED BASES / MAXIMUM AMPS

- 120/240V - 400 AMPS MAX
- 240V DELTA - 120/240V DELTA - 400 AMPS MAX
- 277/480V - 200 AMPS MAX

TYPICAL
SELF-CONTAINED/UNDERGROUND METER
SOCKET FOR USE ON 4 WIRE 3Ø
SERVICES. ALL VOLTAGES
UP TO 400 AMP UNDER 300 VOLTS SERVICE

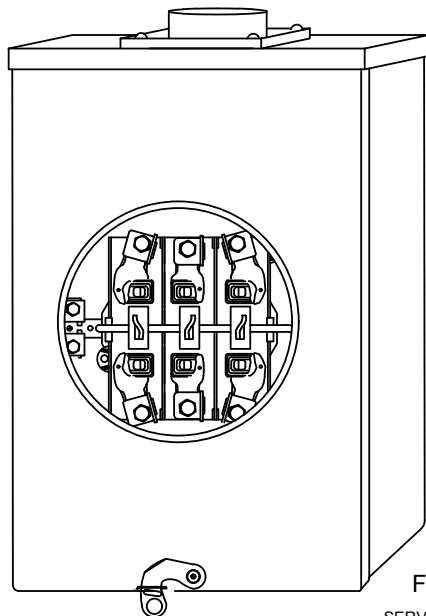

LOOP
FEED IN

SERVICE LATERAL
FURNISHED BY CUSTOMER

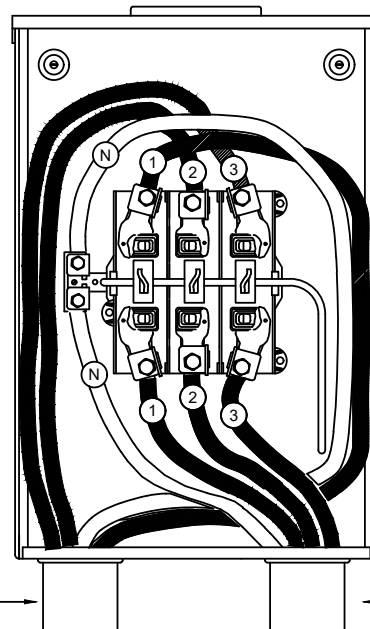

- DELTA 4W HIGH PHASE MUST
BE ON RIGHT HAND SIDE
- PLASTIC PROTECTIVE SHIELD
(NOT SHOWN)
MUST BE IN PLACE
- BY-PASS LEVER
DO NOT OPERATE UNLESS
METER IS IN PLACE

COVER
NOT SHOWN

LOAD OUT

LOAD CONDUCTORS FURNISHED
& INSTALLED BY CUSTOMER

NOTE:

CONDUIT SHALL ENTER SOCKET THROUGH LEFT OR RIGHT
KNOCKOUT BUT NOT THROUGH CENTER KNOCKOUT.

TYPICAL METER INSTALLATION FOR OVERHEAD SERVICE ONLY 1 CABLE PER PHASE UP TO 200 AMPS (UNGROUND DELTA)

***IMPORTANT NOTICE:**
PULLING METER DOES NOT DEENERGIZE SERVICE.
ON BØ DISCONNECT LINK MAKE SURE CENTER LEG IS SOLID AND TIGHT.

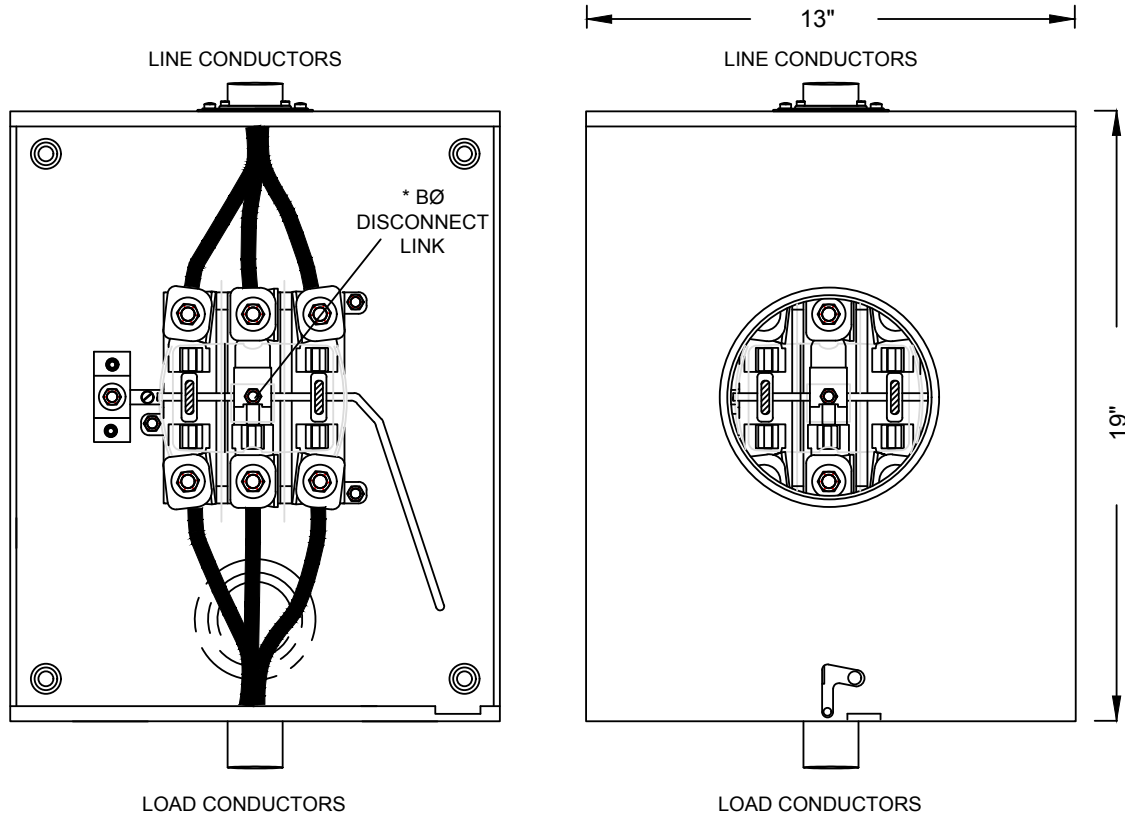

NUMBER OF CONDUCTORS	MAXIMUM CONDUCTOR SIZE	
	COPPER	ALUMINUM
SINGLE (MAX. OF 1 PER LEG)	#6-350MCM	#6-350MCM

EQUIPMENT	FURNISHED BY	INSTALLED BY
METER	UTILITY	UTILITY

CONTRACTOR NOTES:

1. Contractor shall install equipment at the location designated by LG&E/KU Service Locators or Meter Department Supervisors.
2. The installation must be acceptable to LG&E/KU before the service is energized.
3. The meter socket enclosure shall not be used as an auxiliary gutter or junction box.

NOTE:

1. Load break disconnect switch is provided/installed by the customer.
2. Distance between meter base and disconnect to be a minimum of 6 inches and a maximum of 3 feet.
3. Meter base to be installed at a typical height of 5'-6" to the center of base above grade.
4. Disconnect to be installed on either side of meter base at the same level. Do NOT install disconnect directly above or below meter base except where approved by LG&E/KU.
5. Line side wires to be connected to top lugs of meter base and the disconnect switch.
6. Load side wires to be connected to bottom lugs of meter base and the disconnect switch.
7. Customer is responsible for the line side connection to the disconnect switch.
8. Customer is responsible for the connection between the load side of disconnect switch and the line side of the meter base.
9. Customer is responsible for the connection to the load side of the meter base.

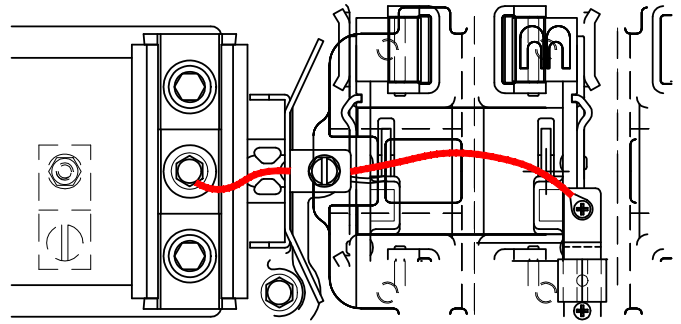

GROUNDING DETAIL

SWITCH REQUIREMENTS

1. Disconnect switch is to be purchased, installed and owned by the customer but will be locked or sealed and controlled by LG&E/KU.
2. Breakers and/or fused disconnects are not allowed.
3. Disconnect must provide a visible opening of the phases.
4. Disconnect must include a handle for operation that is lockable in the open and closed position.
5. Disconnect must be securable by a padlock.
6. Disconnect must be rated for the available fault current per the National Electric Code.

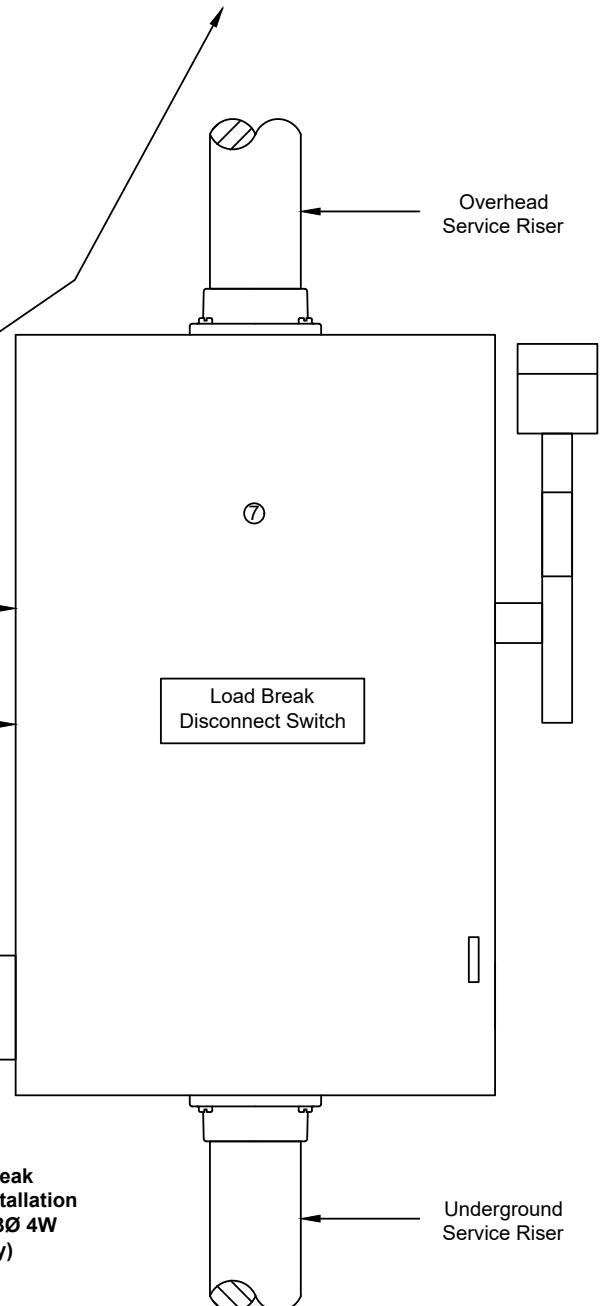
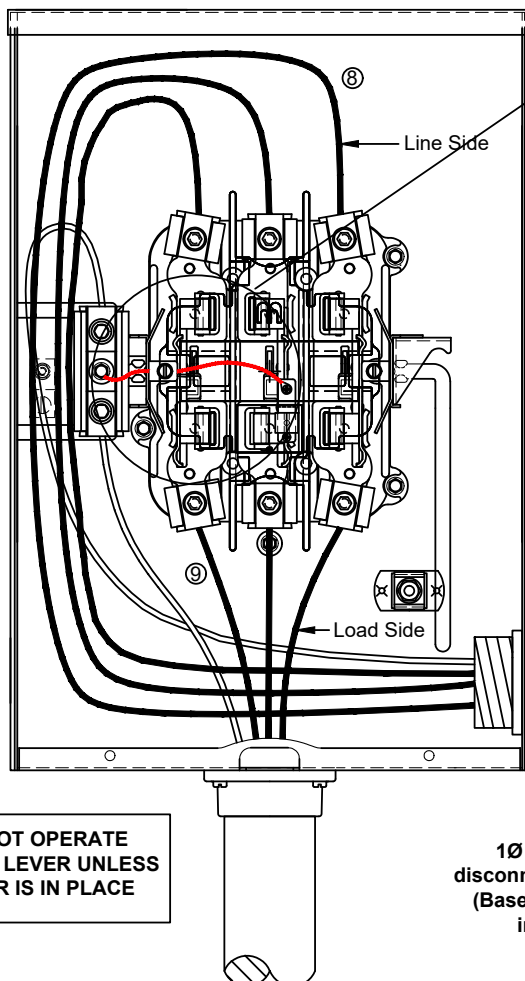

**DO NOT OPERATE
BYPASS LEVER UNLESS
METER IS IN PLACE**

**1Ø and 3Ø loadbreak
disconnect switch installation
(Base shown is for 3Ø 4W
installation only)**



Revised March 2025