

Electric Service Customer Guide

Distribution Operations | Asset Management



Revised March 2025

Kentucky Utilities Company (KU) provides electric service in a defined service territory in and around the Kentucky area. The contents of this handbook are intended to address utility provided electric service issues within the prescribed service territory.

This handbook provides KU and ODP customers and/or their contractors with important information to help assure that customer owned electrical facilities interface safely and reliably with those of the utility. It presents KU/ODP approved construction methods for facilities, including metering facilities, provided by the customer for the utility's use. It also details certain requirements for the construction of the interface point between customer and utility wiring. Additionally, it addresses some important procedural aspects involved with service modifications, repairs and conversions. Following the instructions in this manual will help KU/ODP meet your needs in a timely and efficient manner. Although the book covers service requirements for the most common types of installations, it is an abbreviated guide and does not cover service requirements for complex or special installations. KU/ODP service representatives are available to assist customers in complying with the requirements of this handbook and to provide additional support that may be required to complete complex or non-standard projects.

The intention of this guide is to meet or exceed the requirements of the Kentucky Uniform Building Code, National Electrical Code, Kentucky Public Service Commission Rules and Regulations, National Electrical Safety Code and other relevant publications. However, the information contained herein does not preempt any of the rules, codes or regulations contained in the aforementioned publications. It is the customer's responsibility to notify KU/ODP of any conflicts between utility standards and the requirements of any of the above publications.

The Kentucky Uniform Building Code requires that all customers' provided electrical facilities meet the requirements of the National Electrical Code and any other state or local ordinances in existence at the time of installation. It also requires that all new electrical facilities and any repairs or modifications made to existing electrical facilities be inspected and approved by a certified electrical inspector of the Inspection Authority having jurisdiction. KU/ODP is prohibited from extending or reconnecting permanent service before the Authorized Inspection Authority has approved all work.

By publishing this handbook, KU/ODP is not assuming liability or responsibility for the customer's internal wiring, equipment or equipment operation. Furthermore, KU/ODP maintains the right to refuse service to installations, which do not comply with KU/ODP requirements for service or are found to be either unsafe or unacceptable to the Authorized Inspection Authority. KU/ODP is not responsible for the continuing inspection or surveillance of the customer's wiring, equipment or equipment operation.

KU/ODP recognizes that alternate designs may be permissible under governing codes and regulations. However, KU/ODP must grant approval to any alterations or exceptions to the requirements of this guide prior to construction. ***KU/ODP reserves the right to modify the requirements found in this handbook or any of its service policies, procedures and/or standards at any time. It is the responsibility of the customer or contractor to ensure that any referenced document is the version currently approved for use by KU/ODP. It is also the responsibility of the customer to notify KU/ODP of any changes to existing wiring, equipment, building structure, electrical loading and/or other service requirements that may affect safety or electric system performance.***

The Electric Service Handbook—Customer’s Guide is intended to be a helpful reference for customers and their builders and electrical contractors who are planning a new electrical service within the Kentucky Utilities Company (KU) and/or Old Dominion Power (ODP) service territory. It also details requirements for other types of common electrical work that involves KU/ODP, such as rewiring work, damage repair and conversions of electric services from overhead to underground. It provides important information on the requirements for temporary and permanent electric service for residential, commercial and industrial installations. Old Dominion Power Company is a unit of the Kentucky Utilities Company (KU), headquartered in Lexington, Kentucky. All references in this handbook to Kentucky Utilities (KU) also apply to Old Dominion Power (ODP). There are, of course, a few exceptions that may not be covered in this publication.

Throughout this book, the term “Customer” is used generically to address the party responsible for meeting the service requirements found in this handbook. In reality, the customer’s electrical contractor and/or builder will utilize much of the information in this handbook. However, the customer is ultimately responsible for meeting the requirements outlined in this handbook.

The contents of this handbook are intended to guide the customer through all of the necessary steps to arrange for service. It also contains detailed drawings that cover many of the requirements that must be met before KU/ODP can provide service. While the information in this book covers the requirements for most common types of new services, it is not intended to cover every KU/ODP policy and/or standard for service that may apply or provide all of the necessary information needed for complex or special installations. KU/ODP’s service representatives are available to assist customers and contractors in complying with the requirements of this handbook and to provide any additional support that may be needed to complete complex or other non-standard projects.

KU/ODP reserves the right to modify the requirements found in this handbook or any other service policy, procedure and/or standard at any time. It is the responsibility of the customer or other responsible party to ensure that any referenced document is the version currently approved for use by KU/ODP.

Kentucky Utilities Company (KU) is a regulated electric utility, based in Lexington, Kentucky, serving customers in 77 Kentucky counties and five counties in Virginia (under the name Old Dominion Power—ODP).

HISTORY

Kentucky Utilities officially began business on December 2, 1912 serving five properties (Versailles, Lawrenceburg, Somerset, Elizabethtown and Shelbyville). KU acquired Old Dominion Power Company (ODP) in 1926.

In 1998, KU's parent company, KU Energy, was acquired by LG&E Energy, which owned neighboring utility Louisville Gas and Electric Company. The acquisition of KU Energy, along with the 25-year lease agreement with Big Rivers Electric, more than doubled the size of LG&E Energy.

UK-based Powergen bought LG&E Energy in 2000, and in 2002, Powergen was acquired by Germany's E.ON. In 2003, E.ON transferred LG&E Energy from Powergen to another subsidiary, E.ON US Holdings.

In 2010, PPL Resources of Allentown, Pennsylvania reached an agreement with E.ON AG to purchase E.ON US. PPL Corporation is a large Fortune 500 company with regulated operations and unregulated activities in the US and the United Kingdom.

QUICK FACTS

- KU serves 485,253 electric customers in Kentucky; ODP serves 29,730 electric customers in Virginia.
- KU's service area covers 6,600 noncontiguous square miles.
- KU's total generation capacity is 4,570 megawatts.

LG&E/KU/ODP Service Territories

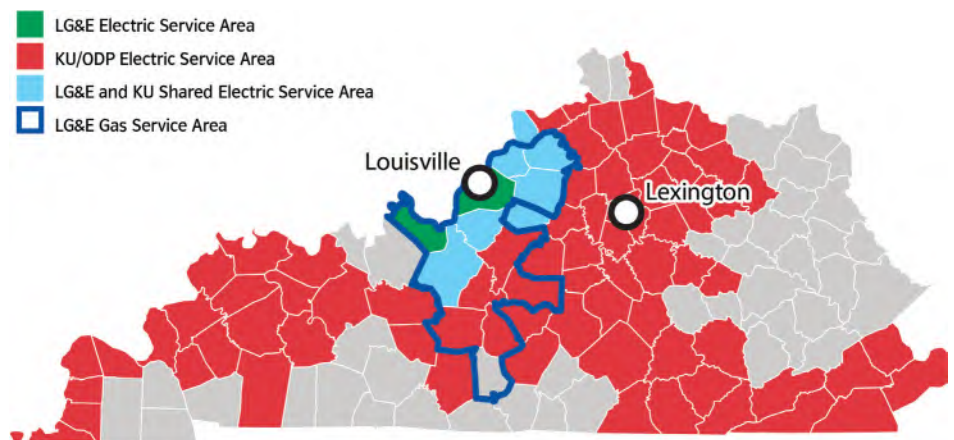

KU/ODP CUSTOMER SERVICE BY PHONE

TOLL-FREE 1-800-981-0600

(MONDAY THROUGH FRIDAY FROM 7AM TO 7PM)

ELECTRICAL SAFETY

Safety First—Providing Safe Electrical Service.....	8
Personal Safety	8
Downed or Low Power Lines	8
Lines on Vehicles.....	8
Electrical Safety—A Practical Guide for Children and Adults	9
Electric Safety Tips for Children	9
Making Home Improvements	9
Contractor Safety	10

GENERAL INFORMATION

Introduction	12
Service Rates, Rules and Regulations.....	12
Other Sources and Applicable Codes.....	12
Applying for Electric Service.....	13
Service Requirements, Restrictions and Limitations.....	14
Steps for Obtaining New Electric Service.....	16
Planning for Service	18
Permitting and Inspection of Electrical Work.....	18
Customer Contributions for Construction	18
Customer Information	18
Electric Service Design Parameters.....	20
Available Service Voltages and Configurations.....	20
Choice of Overhead and Underground Service	22
Service Location.....	23
General Metering Information	23
Easements and Clearance Requirements.....	24
Requirements for Electric Service Equipment.....	25
Access and Clearance to KU/ODP Service Equipment	25
Special Equipment Requirements	26

METER INFORMATION

General Requirements.....	28
Obtaining Meter Bases And Associated Equipment	30
Installation of Metering Equipment.....	30

TEMPORARY AND PERMANENT SERVICE

Temporary Services 600 Volts Or Less.....	37
Temporary Overhead Services	38
Temporary Underground Services.....	39
General Information for Permanent Residential Service	41
Grounding.....	41
Motor Restrictions	41
Available Service	42

Permanent Single-Family Residential Electric Services.....	43
Line Extensions	43
Permanent Overhead Residential Electric Services.....	43
Permanent Underground Residential Electric Services.....	44
Mobile Home Services	45
Line Extensions	45
Service Equipment	45
Overhead Services.....	46
Underground Services	47
Multi-Family Structures	49
Line Extensions	49
Special Metering Requirements	49
 COMMERCIAL/INDUSTRIAL SERVICES	
Introduction	51
Type of Service	51
Service Voltages	51
Installation Costs.....	52
Number/Type of Services	52
Grounding.....	52
Overhead Services (600 Volts or Less).....	52
Permanent Underground Service (600 Volts or Less).....	53
 SPECIAL PROCEDURES	
Overhead to Underground Service Conversions.....	56
Conversion Costs	56
Rewire Procedure	57
 SUPPLEMENTAL INFORMATION	
Reading Your Own Meter	59
Emergency Power Sources.....	60
Requirements For Emergency and Standby Generators.....	60
Portable Generator Safety.....	60
Landscaping And Vegetation Near Electrical Lines.....	61
Clearance To Overhead Lines.....	61
Tree Safety.....	62
Clearance To Underground Lines.....	62
Planting Near Electrical Equipment	63
 SERVICE-RELATED DRAWINGS	
	65

ELECTRICAL SAFETY



ELECTRICAL SAFETY

Safety First—Providing Safe Electrical Service

The health and safety of our customers and employees is our highest priority. We also believe strongly in the concept that safety is everyone's responsibility. KU employees and contractors will not perform any work in areas considered unsafe. Our employees or contractors will not install or connect any electrical facilities that are, in the opinion of our employees or

contractors, unsafe or not in compliance with utility requirements or governing codes and regulations. Both KU and customer-owned electrical facilities must be planned, designed, built, maintained and operated to minimize the risk of injury and property damage during construction and throughout the operating life of the facility.

Personal Safety

DOWNED OR LOW POWER LINES

At KU, we believe in Safety First, and the safety of our customers and the public is important to us. We rely on you to tell us about unsafe conditions, such as downed power lines. Power lines can be brought down by equipment failures or during storms by lightning and high winds, by fallen trees or by other damage, such as vehicle accidents. Never touch, move or go near any kind of downed or low hanging line—even if it looks harmless.



If you see a downed or low wire **call us at 1-800-981-0600, 24 hours a day, 7 days a week.** Stay away from the downed or low wires and use extreme caution since there is no way to know if a wire is an energized electric line or something else like a

telephone or cable television line. You don't have to touch a downed line to be seriously injured. You can be shocked just by going too close to a downed line because the earth in the area around the fallen line becomes energized. Even if you do not see sparks, you should assume the line is energized. Always warn others to **STAY AWAY** from downed lines.

If a person is injured, immediately call 911. KU/ODP toll-free at 1-800-981-0600 to report downed lines. NEVER touch downed power lines or try to move a person or object in contact with these lines!

Serious injury and even death can result from coming into contact with a downed electric line. Touching any object, such as a fence, vehicle, building or even a tree that is in contact with a downed or low line can also injure you. Assume that touching anything near or in contact with a downed line is just as dangerous as the downed line itself. Stay away.

Remember, Be Safe! Assume every low hanging or downed line is an electric line. Report it as quickly as possible and KU will send someone to investigate. Stay away and help keep others away until KU arrives and makes the area safe.

LINES ON VEHICLES

Should a fallen line come into contact with a vehicle, the vehicle itself may become energized. In many cases, the safest thing to do is stay in the vehicle until help arrives. Keep others away from the vehicle. Any person attempting to touch or leave the vehicle could be electrocuted. If possible, stay in the vehicle until KU/ODP has made the line safe. If it is not safe to remain in the vehicle in the event of a fire or other danger **do not step from the vehicle. Jump as far away as possible keeping both feet together. NEVER touch the vehicle and the ground at the same time.** Hop or shuffle your feet in very small steps to move to safety.



ELECTRICAL SAFETY

A Practical Guide for Children and Adults

With the flick of a switch, you can heat, cool and light your surroundings with electricity. It's so easy that it seems as if electricity could never be any trouble, but care must be taken with this helpful energy we need for everyday living. Safe use of electricity can prevent fires in your home and injuries to you and your family. Here are some tips for all members of your household to follow when using electricity.

Please read and discuss these safety tips with your children, and do not forget to tell them to **"play it safe"** around the house and outdoors by staying away from electrical equipment and wiring. Most importantly, tell them to call an adult immediately if they see any problems with electrical wires or equipment.

Electric Safety Tips for Children

INDOORS

NEVER touch electrical appliances, light switches or anything using electricity if you have wet hands or are standing on a wet surface. Electricity travels through water, and you could be shocked or seriously injured. Keep all electrical devices away from bathtubs and showers.

NEVER stick metal objects in electric outlets or inside appliances or other electrical equipment. Again, you could be shocked or seriously injured.

ALWAYS install electric outlet protectors when small children will be around.



OUTDOORS

NEVER climb or play around trees that are close to overhead lines! If you see a tree limb that is too close to a line, call KU/ODP at 1-800-981-0600 to have it removed. If a pet or any animal gets trapped on a utility pole, **call KU/ODP at 1-800-981-0600 anytime**, day or night, and let us help you. Never try to help the animal yourself!

NEVER climb on or play near the metal or brick fences that surround electrical equipment. The fences around electric substations are there to keep people away for their safety. Never try to get a ball or other object that has fallen inside the fence. Do not reach through or under the fence to retrieve objects. **DO NOT** try to get it yourself. **Call KU/ODP at (800) 981-0600**, and we'll be happy to help.

NEVER fly drones, kites or model airplanes anywhere near overhead lines! Play in parks or other open spaces with no power lines to prevent the danger of severe injury. Even a kite string or toy control wire can carry electricity and cause serious injury should it touch a power line.

Making Home Improvements

Making home improvements—such as adding a garage or a pool to your property—can be a good investment that can add to the value of your home. Before you build, however, you should plan the addition or installation carefully to save yourself time and inconvenience. If you're adding an extension, such as a new room or a screened porch, consider the new roofline carefully. If a power line will come near the completed addition, be sure to call us first. It may be necessary to have the line moved before you begin the project.

If you are thinking about installing a swimming pool, do not build it under electrical lines. If a power line should drop into the pool, you or your family could be injured or killed. Pools should only be built in areas at least 25 feet away from the power line in each direction with at least 17 feet between overhead lines and diving boards, decks or slides.

Also, pools and decks should be installed at least five feet away from all underground lines. Improperly situated pools must be corrected at the customer's own expense or we will be forced to shut off electricity to the home.

If you have further questions, please call us before you begin to build.



Do you work near power lines?

If so, you should be aware that electrocution is one of the top five causes of workplace deaths in the U.S. If you forget about safety precautions or don't know about or understand the risks

involved in the work being done, you or someone you work with could be electrocuted. It only takes one mistake.

Plan ahead before you start work

- Survey the job site carefully before work begins; identify any safety risks and anticipate potential safety problems. Hold a safety and or tailgate meeting each day before work begins at each work site to remind workers what to look out for. Continually warn others about nearby power lines and other electrical hazards. Consider all overhead lines to be energized power lines, no matter what they look like. Note a hazard zone around power lines and stay outside of it.
- If you must work near lines, barricade or otherwise mark the area off and follow all OSHA-required work practices. When working within what could be an unsafe distance to KU/ODP's electric facilities or that may otherwise be in violation of federal, state or local regulations, the individual(s) must notify KU/ODP at **1-800-981-0600**. KU/ODP will work with the customer to ensure the work can be performed safely and may cover, de-energize or temporarily move its facilities in the work area as deemed appropriate to provide a safer working environment, provided reasonable advance notice is given. While covering lines can make a job site safer, it is not a replacement for safe work practices and is not intended to allow equipment to come too close or contact lines. KU/ODP reserves the right to recover the cost of any such work when requested by the customer.
- Before digging anywhere in Kentucky, call Kentucky 811 (Before You Dig) by dialing 8-1-1 or calling **1-800-752-6007** to have your underground utilities located and marked. Not only will this make work safer, but it also reduces potential costs to repair damage to KU/ODP's electric lines or those of other utilities. There is no cost to locate underground utilities, but you must call at least two days before starting work. Outside of the Lexington area (Anderson, Bourbon, Clark, Fayette, Franklin, Harrison, Jessamine, Madison, Montgomery, Scott, and Woodford counties), you must also contact KU at **1-800-981-0600** at least two days before work begins to have KU mark any underground electric lines in the area, again, free of charge. Visit our website at lge-ku.com and input your county name to see if you can make one call to Kentucky 811 or if you need to contact both 811 and KU. In Virginia, call 811 Miss Utility and allow 48 hours before beginning excavation.
- Report any activities that could damage utility poles, such as excavations that might reduce pole stability by calling KU/ODP at **1-800-981-0600** before work begins. Temporary bracing may be necessary, and KU/ODP may impose a charge to cover the cost for any work required.

Keep your distance

OPERATING A BOOM OR CRANE

Don't rely only on ground rods, line covers, warning devices or insulating boom guards to protect you from a power line contact. Instead, designate a person whose only responsibility is to direct you away from power lines.

WORKING WITH POLES, LADDERS OR ANTENNAS

Keep them from reaching or falling into lines by making sure

they clear lines by at least 10 feet in every direction. Under some circumstances, electricity can arc to equipment that is close to a power line, even if it is not touching the line.

WORKING ON THE GROUND

Stand clear of equipment, guy wires and loads that will instantly conduct electricity if they hit a power line. If you're guiding a load, be aware of the location of the crane boom and power lines.

If you hit a power line

- If you're in the equipment, stay there if you can! It is safer to stay in the equipment than to try to get out. Try to move the equipment away from the line. If you cannot safely move the equipment, stay where you are and wait for rescue workers.
- Have someone call KU/ODP at **1-800-981-0600** immediately to shut off the power supply. Call 911 for medical help if anyone has sustained injury. Warn everyone to stay away from the load, guy wires, equipment and anything in contact with the equipment, all of which could be conducting a deadly amount of electricity.
- If you must get out of the equipment because of fire or other danger, jump free rather than stepping off. Never touch a grounded surface and equipment that is contacting a power line at the same time.



GENERAL INFORMATION

GENERAL INFORMATION

Service, Rates, Rules & Regulations

All electric service supplied by KU is provided in accordance with the applicable rates, rules and regulations of the Kentucky Public Service Commission (KPSC), psc.state.ky.us and Kentucky Utilities Company lge-ku.com

The administrative rules of the KPSC can be found in the document ***Kentucky Administrative Regulations pertaining to the Kentucky Public Service Commission, Title 807, and Chapter 7—Utilities***. This document is available for public inspection at the Commission, on the KPSC Internet site (above) and also at the KU Internet site (above) at <http://lge-ku.com/home> then look for KU or ODP. This document establishes general rules and regulations for all types of public utility service (water, gas, electric, telephone, etc.) that falls under the jurisdiction of KPSC. Specific sections of this document apply to electric service.

KU rates and requirements for electric service are documented in ***Kentucky Utilities Company Rates, Rules and Regulations for Furnishing Electric Service***. This document can be found at each of the same locations as the KPSC administrative regulations. This document sets out specific rates and requirements for electric service provided by KU within the defined service territory.

KU provides electric service to all new residential customers under a single rate plan. Non-residential customers will be



placed in one of several different customer plans depending on factors such as expected peak demand and other characteristics of use. The rates and chargeable energy components for non-residential service plans vary by the class of service, and, in some cases, by the service voltage provided and even the time of use. Each class of service will also have different service restrictions and customer requirements. KU/ODP's service representatives will work closely with customers to determine the appropriate rate plan and all other necessary service parameters. This will ensure new customers are placed on the most cost-effective rate plan available for their service size, voltage and characteristics of use.

Other Sources and Applicable Codes

NATIONAL ELECTRICAL SAFETY CODE (ANSI C-2)

The NESC® covers work practices and requirements for electric supply facilities under the control of public and private utilities and certain other similar systems under the control of qualified persons, such as those associated with a large industrial complex. The NESC® covers the requirements for utility systems up to the Point Of Delivery. The NESC® also covers street and area lighting under the exclusive control of utilities or other qualified employees operating similar systems. (IEEE Service Center, 445 Hoes Lane, P.O. Box 1331, Piscataway, New Jersey 08855-1331.)

NATIONAL ELECTRICAL CODE (ANSI-NFPA 70)

The NEC® covers, in general, the design, alteration, modification, construction, maintenance and testing of utilization (i.e. non-utility) wiring and equipment, including certain utilization wiring of a temporary nature. The NEC® code generally covers all aspects of utilization wiring beyond the Point Of Delivery. (National Fire Protection Association, Batterymarch Park, Quincy, Massachusetts 02169.)

KENTUCKY BUILDING CODE

This document establishes rules that are intended to establish a uniform building code in the state of Kentucky (Department of Housing, Buildings and Construction) dhbc.ky.gov

GENERAL INFORMATION

Applying For Electric Service

The first step in arranging for new service is to contact KU and make an application for service. KU cannot begin the process of arranging for service until the application for service has been accepted. To avoid unnecessary delays in receiving service, please make your application for service as far in advance as possible of the date service is required. KU will require sufficient time to design, plan and install the necessary electrical facilities for new services. Additional time will be required if KU must extend or enhance facilities to provide service.

Requests for new temporary and permanent residential, commercial and industrial services can be made by phone through Customer Service (residential services) or the Business Service Center (commercial/industrial services) or online at lge-ku.com

For Residential Services, contact:
Customer Service1-800-981-0600

For Commercial/Industrial Services, contact:
**Business Service Center1-800-383-5582 or
859-367-1200**

At the time an application for new electric service is made, the customer should be prepared to provide the following:

- ▶ Name(s) on the account
- ▶ Responsible parties' Social Security Numbers
- ▶ Service address (city, street address and zip code) and mailing address, if applicable
- ▶ If the service is for a home, and the home will be constructed in a subdivision, you will also need to provide the subdivision name and lot number
- ▶ Current home and work telephone numbers
- ▶ Expected in-service need date for new service
- ▶ Temporary service requirements (if necessary)

Special Notes:

- If both temporary and permanent electric service is needed at the same site, separate applications must be completed. However, both applications can be made at the same time and the process is the same as applying for permanent service. See the section on Temporary Electric Service.
- The submission of an application for service constitutes the customer's permission for KU/ODP to conduct a credit history check..

At the time an application for service is made, the customer will be given an account and/or order number. This information should be retained for the purpose of tracking the progress of the service request. The customer's information will be given to the Operation Center in that area and if necessary, a KU/ODP representative will contact the customer to guide them through all of the necessary steps to acquire service.



GENERAL INFORMATION

Service Requirements, Restrictions And Limitations

Certain restrictions and limitations apply for establishing and maintaining electrical service. Below is a partial list of some of these restrictions and limitations.

CONTRACT ACCEPTANCE AND TERMS

KU/ODP has the right to reject, **for valid reasons**, any application or contract for service.

Applications for electric service are not transferable, and new occupants of premises are required to make an application for service before service is provided. Customers who have been receiving electric service must notify KU/ODP when they wish to discontinue service and are responsible for paying for all electric service furnished until the time a request to discontinue service has been made.

KU/ODP may require a minimum cash deposit or other guarantee to secure payment of bills. Service may be refused or discontinued for failure to pay the required deposit. For more information regarding KU/ODP's deposit policy, contact Customer Service at **1-800-981-0600**.

USE OF SERVICE RESTRICTIONS

Customers are prohibited from using an electric service for purposes other than those set forth in the customer's application or contract. All of the customer's equipment, apparatus and appliances must have such characteristics or be equipped with corrective devices to enable KU to maintain a satisfactory standard of service.

Electric energy furnished under KU standard application or contract is for the use of the customer only. No customer shall resell such energy to any other person, firm or corporation without the written consent of KU and approval of the KPSC.

REFUSAL OR DISCONTINUANCE OF SERVICE

In accordance with and subject to the rules and regulations of the KPSC, KU retains the right to refuse or discontinue service to an applicant or customer under certain conditions. KU will charge the customer for disconnections and reconnections of electric service resulting from non payment of bills, unsafe conditions or for violations of the company's rules and regulations. Refusal or discontinuance of service with or without notice, and without liability, can occur under various other circumstances. These conditions are set forth in KU Tariffs filed with the KPSC and the rules and regulations of the Commission.

Since it is KU's obligation to provide safe and satisfactory service to all customers, KU reserves the right to refuse or discontinue service without notice if, in the opinion of KU, the customer's wiring, equipment or appliances are unsafe or unsuitable for receiving electric service or are harmful to the service of other customers. KU will make a reasonable effort to notify the customer prior to disconnection and shall inform the customer of the steps, which must be taken to have service restored.

COST OF TEMPORARY SERVICE

The customer is required to pay the entire cost of all material, labor and expenses incurred by KU/ODP associated with supplying electric service for any temporary, short-term use, or intermittent loads, including seasonal or infrequently used loads.

SERVICE AND LIABILITY LIMITATIONS

KU is not liable for any injury or damage to persons or property resulting from the presence, use or abuse of electricity on the customer's premises. KU shall be held harmless for any injury or damage to persons or property resulting from defects in customer wiring, equipment, apparatus or appliances or resulting from any cause whatsoever other than the negligence of KU.

KU will exercise reasonable care and diligence in an endeavor to supply service continuously and without interruption, but KU does not guarantee continuous service. It is the responsibility of the customer, when deemed necessary or desirable, to install any equipment necessary to protect the facilities against disruptions in service, including complete or partial loss of service (lost phase), voltage surges, over/under voltage conditions, etc.

KU shall not be liable for any loss or damage resulting from interruption, reduction, delay or failure of electric service not caused by the willful negligence on the part of KU, or resulting from any cause or circumstance beyond the reasonable control of the company. Disruptions considered beyond the control of the utility include, but are not limited to, outages resulting from storm conditions, lightning, interference by animals, unanticipated equipment failures, tree contacts, high water conditions, public interference (such as vehicle accidents, vandalism, etc.), failure of customer equipment, etc. KU is also not liable for any loss of service resulting from the need to de-energize lines and equipment without notice to allow employees and/or its contractors to safely perform work or to respond to emergencies.

CUSTOMER ELECTRICAL LOADING AND ENERGY USE RESTRICTIONS

KU reserves the right to place restrictions on the type and manner of use of all customers' electrical equipment. Examples of loads that may be restricted include loads too large for the service ratings, highly fluctuating loads and other offending loads such as those with objectionable harmonic levels or characteristics otherwise detrimental to KU's electrical system or its ability to provide acceptable service to other customers. When necessary, KU will require the customer to remove or correct any unacceptable loads at their own expense.

KU service connections, transformers, meters, and associated equipment used to provide service have definite capacity

GENERAL INFORMATION

limitations and can be damaged by changing service requirements, especially increased loading requirements which can overload utility equipment. Therefore, the customer must notify KU/ODP prior to increasing loading requirements or making any other alterations to the service entrance equipment that could affect utility equipment. Failure to properly notify KU of such additional requirements could result in damage to the customer's and/or the KU facilities resulting in unexpected service interruptions and delays in restoring service while repairs are made. Customers may also be subject to charges by KU/ODP for corrective actions required to restore the utility's system and for damage to other customers' facilities.

The customer will not be permitted to install wiring or connect any device that is detrimental to the KU electric system or to the service of other customers. KU will assume no responsibility for

the customer's electrical wiring or apparatus or for the maintenance or removal of any portion thereof.

The Point Of Delivery for electrical energy supplied by KU shall be at a service point designated by KU. At this point, KU facilities are physically connected with the facilities of the customer. The Point Of Delivery varies by the characteristics of the service and whether the service is provided overhead or underground.

The customer is responsible for furnishing, installing and maintaining all electrical apparatus and wiring to connect with KU electric service facilities. All customer wiring and equipment shall be installed and maintained in conformity with applicable codes and the rules and regulations of the Inspection Authority having jurisdiction.

GENERAL INFORMATION

Steps For Obtaining New Electric Service

Customer/Contractor Steps

1. Customer must call KU/ODP to apply for service.

For Residential Services:

Customer Service 1-800-981-0600

For Commercial/Industrial Services:

**Business Service Center 1-800-383-5582 or
859-367-1200**

All requests for new temporary and permanent residential, commercial, and industrial services MUST be made through Customer Service (residential services) or the Business Service Center (commercial/industrial services). At the time of requesting service, KU/ODP must be given a valid address. Please provide ALL available information (street name, house number, lot number, etc). The customer should:

- Retain account and/or order number for future reference.
- Provide the best known need date for service.

Application for a temporary service and a future permanent service at the same location can be made at the same time even though they are processed as two separate service applications.

Note: Customer MUST contact KU/ODP to apply for service before applying for service inspection by either the owner or the responsible builder/contractor.

2. Customer must work with the appropriate KU/ODP representative to receive an electric service and meter location.

3. Customer must provide detailed load information and two copies of the site plan for all commercial or industrial services.

Load data must be provided on KU Electrical Load Data Submittal Sheet. A copy of the electric data submittal form can be found in section 7 of this handbook or electric forms

can be requested from the KU/ODP Representative. Completed forms should be returned to the KU/ODP representative.

4. Customer must sign a service contract and pay any amounts due in customer contribution (if required) before any work can be performed.

5. Customer must obtain a permit for electrical work and have all work inspected and approved.

The Kentucky Uniform Building Code requires the electrical inspection of all new buildings before service is connected. After service has been requested, the electrical contractor or responsible party should contact the appropriate Inspection Authority having jurisdiction in their area to arrange for the inspection and approval of all electrical work.

When the Authorized Inspection Authority has approved

electrical work, an approval sticker will be posted at the job site. KU/ODP must be notified of the approval by the Authorized Inspection Authority before scheduling work to energize the service. KU/ODP cannot energize the service if there is no approval sticker in place. In Virginia, some areas do not use an approval sticker. In these areas, inspection is returned to ODP's local office by the inspector.

GENERAL INFORMATION

6. Customer must have installed all KU/ODP required-customer provided underground facilities and notified KU/ODP when these facilities are ready for inspection..

KU/ODP requires commercial and industrial customers to provide certain service facilities on private property for use by KU/ODP. This includes items such as underground duct, equipment pads, manholes, etc. that may be required to provide service. These facilities must be constructed to KU standards. Following acceptance of the completed facilities by

KU, control of these facilities is transferred to KU; however, the customer continues to own and be responsible for any necessary maintenance of these facilities. These facilities must be completely installed, inspected and approved by KU before service work can begin.

7. Customer must convey to KU/ODP all necessary Rights-of-Way.

The customer must convey to KU/ODP all necessary Rights-of-Way on the customer's property required for KU/ODP to

place facilities and provide service. Any Rights-of-Way needed from other property owners will be obtained by KU/ODP.

8. Customer must provide a centerline drawing for underground commercial/industrial services, which completely describes the location of customer provided facilities and any easements granted on the customer's property (Commercial and Industrial Customers Only)

KU/ODP representatives will work with customers to finalize the location of all KU/ODP electric facilities on the customer's property. It is the customer's responsibility to provide detailed survey information, including bearings and calls for any underground facilities provided by the customer for KU/ODP use as

well as any easements granted KU/ODP for the extension of electric facilities. Facility and easement information need not be provided for any sections parallel to a property line provided a detailed property record plat has been provided.

KU/ODP Steps

1. KU/ODP will design the utility service and provide the customer any necessary documents related to the service for use by the customer, including design and construction drawings, forms, standards, etc.

2. KU/ODP will work to obtain all necessary permits from public entities for the installation of KU/ODP facilities in public way. KU/ODP will also obtain all work permits required to perform work in public way associated with providing service to the customer. KU/ODP will obtain all necessary easements required from other property owners, if applicable.

3. KU/ODP will install all required utility service facilities and energize the service once all of the above customer and contractor requirements have been met and KU/ODP has been notified that the Authorized Inspection Authority has approved all work.

GENERAL INFORMATION

Planning for Service

The following sections provide some general information that customers should consider when designing and preparing for electrical service. More comprehensive information about many of the topics discussed below can be found elsewhere in this manual.

PERMITTING AND INSPECTION OF ELECTRICAL WORK

In the majority of the territory served by KU, local electrical inspection authorities have jurisdiction for determining the safety and suitability of customer-owned electrical systems. KU works closely with these agencies to ensure that electrical service can be provided and used safely.

All new customer-owned electrical systems must be inspected and approved by the appropriate Authorized Inspection Authority before KU/ODP will energize a service.

KU also requires an inspection of existing services when they have been disconnected for any safety reason, have been



repaired, expanded or otherwise modified or have been inactive for more than one year. KU can also require a re-inspection of a service at any time if, in the opinion of KU, providing electrical service has created, or could create an unsafe condition. The customer must arrange to have a licensed electrical contractor complete any necessary work and have the facility re-certified by the appropriate inspection agency. Service restoration cannot occur until the Authorized Inspection Agency notifies KU of its approval of the electrical facilities.

CUSTOMER CONTRIBUTIONS FOR CONSTRUCTION

In accordance with the tariffs, customers are responsible for all costs associated with temporary services. In almost all cases, customers will also be responsible for all costs associated with serving seasonal, temporary or lightly used services.

Customers may also be responsible for some or all of the cost for permanent service. In many cases, KU/ODP can provide permanent electrical service from existing facilities in the area with little or no cost to the customer. Sometimes, however, KU/ODP must extend electric lines to provide service. Extensions of KU/ODP facilities to serve a new site are made in accordance with the provisions of the Company's Rates, Rules and Regulations for Furnishing Electric Service. The portion of such extensions that KU/ODP will furnish at its cost depends upon the service type, the size and type of loads and the type of KU/ODP facilities available at the service location. KU/ODP service representatives will inform the customer of any service related costs.

KU is obligated to provide service to each customer in the least-cost manner. The customer is responsible for the incremental cost of any service request that exceeds the minimum standard or results in any increased cost to serve. This includes most requests for underground service, requesting service at locations other than the one specified by KU, changes in specified service voltage, etc. KU's service representative will notify the customer of any additional charges.

KU is not obligated to begin design or construction work until the customer has signed a contract for service. The contract sets out terms and conditions for service and obligates a customer to pay for electrical service and any other service-related costs before construction begins. No service or metering equipment can be installed until this step is completed.

CUSTOMER INFORMATION

To avoid unnecessary delays and/or costs, it is critical that the customer apply for service and notify KU/ODP of service needs as soon as practical. Shortly after applying for service, a KU/ODP service representative will begin working with the customer to gather information and finalize the necessary service parameters. KU/ODP determines the type of electrical service provided based on a combination of the customer's

needs (service size/type/voltage), characteristics of use and the electrical facilities KU/ODP has or can reasonably make available at the service location. The information KU/ODP requires the customer to provide varies by the type of service requested. Below is a typical listing of electrical service information that KU/ODP requires.

GENERAL INFORMATION

Planning for Service *(continued)*

RESIDENTIAL CUSTOMERS

The Residential class of service is largely restricted to service for single-family units for lighting, heating/cooling, cooking, refrigeration and other common purposes typical of domestic use. After an application for service is made, a KU or ODP service representative will contact the customer to determine any required service parameters. The customer needs to be able to provide the following information:

- Planned electrical entrance size (in amps)
- Type of service requested (overhead or underground)
- Type of heating (electric heat or electric heat with heat pump)
- Size and, if appropriate, number of A/C units (specified in tons of cooling)
- Type of major cooking appliances (electric)
- Type of water heater, tank or tankless (electric)
- Other large loads (large tools or appliances, pools, hot tubs, saunas, etc.)

Residential services are not designed nor intended to provide service for unconventional or high demand equipment such as

“on demand” water heaters or other intermittent, high demand or frequently started devices such as welders, large motors, etc. If any such equipment interferes with service to other customers or if KU/ODP cannot adequately serve these loads, the customer will have to remove the equipment at their expense. Additionally, the customer is responsible for any costs associated with upgrading KU/ODP facilities to serve any unconventional equipment or loads.

Residential services have maximum starting current restrictions that apply to motors, compressors and other devices that have large starting currents, including HVAC units and associated equipment. **Maximum Locked Rotor (inrush) current is restricted to 125 amps at 240 volt and 50 amps at 120 volts.** These restrictions apply to all motors and other associated equipment arranged for simultaneous starting. Large A/C units or other large motors, compressors, etc. may require supplemental starting equipment to ensure inrush currents do not exceed these values. The customer is responsible for any costs associated with making corrections to the equipment, upgrading KU/ODP service or, if required, removing offending loads if they exceed the above values.

COMMERCIAL AND INDUSTRIAL CUSTOMERS

For commercial and industrial services, the following information must be provided before KU/ODP can begin planning to provide service:

1. Service size, design loads and voltage requested. This information should be submitted on KU/ODP “Electrical Load Data Submittal Sheet”. A sample of this form is provided in Drawings section of this publication.

Load type and size information can usually be provided well before electrical system plans are completed. Because this form contains information used to determine electrical energy requirements, someone experienced in making such assessments should complete it. KU/ODP uses the information to prepare the utility system design and specify equipment for your project. Early completion of this requirement is critical for providing service in a timely manner. Design work cannot begin and equipment cannot be ordered until detailed loading information is provided.

2. Site plan for the facility being served (two copies).

KU/ODP representatives use site plans to finalize location of all KU/ODP electric facilities on the customer’s property. The site plan should indicate all rights-of-way and/or easements,

property lines, streets, electric/gas/water utility lines, building layouts, streams, future buildings, pools, decks, buried objects or other obstructions or facilities that may affect electric service. KU/ODP uses this information to design and construct the facilities necessary to provide safe and reliable service. For KU/ODP to complete its design, the customer must stake all property corners so that the KU/ODP representative can locate easements and/or service routes.

KU/ODP requires additional information when providing underground service. The customer must provide detailed survey information, including bearings and calls, for any underground facilities provided by the customer for KU/ODP use as well as any easements granted KU/ODP for the extension of electric facilities. Facility and easement information need not be provided for any sections parallel to a property line provided a property record plat has been provided to KU/ODP that contains this information. If appropriate, the KU/ODP representative will return one copy of the site plan to the customer approving the electrical service arrangement or detailing any required changes.

GENERAL INFORMATION

Electric Service Design Parameters

When planning a new service, many decisions need to be made before KU/ODP can begin the process of providing service. Some decisions, like service voltage for commercial and industrial customers, must be decided in conjunction with KU/ODP. Other decisions, such as service size, number of phases and whether to request service overhead or underground will usually be made based on customer needs and preferences.

KU/ODP will provide each customer with a single-service voltage/configuration and will provide this service to a single location at the facility. Customers provided with three-phase service are expected to provide any necessary voltage transformation needed for lighting and outlet loads.

The decisions that have to be made by new residential customers are relatively easy. There is only a single service offering, 120/240 volt 1-phase 3-wire service up to 800 amps, unless otherwise approved by KU/ODP. The customer must only decide whether to request the service be provided underground or overhead. If the new home is in an established underground residential subdivision, then service will be provided underground. In other cases, either

type of service can usually be provided although there may be additional costs involved if underground service is requested.

The service choices for commercial and industrial customers are more complex. There are more service voltages and wiring configurations available, but the type of service provided may be restricted by loading requirements and/or by KU/ODP existing facilities available near the service location. When reasonable, KU/ODP provides service from existing electric facilities when existing facilities are appropriate and have adequate capacity or can easily be upgraded to have the required capacity. If existing facilities cannot provide adequate service, the customer can request a specific service voltage and wiring configuration (3-wire, 4-wire, etc.), but the final determination of all service parameters will be made by KU/ODP. Therefore, commercial and industrial customers must work closely with KU/ODP representatives to determine service parameters before beginning their electrical system design. See "Available Service Voltages and Configurations" below for additional information.

AVAILABLE SERVICE VOLTAGES AND CONFIGURATIONS

GENERAL INFORMATION

KU/ODP supplies only alternating current service with a nominal frequency of 60 cycles per second at the nominal voltages identified below.

While residential customers will be provided with a single-service offering, commercial and industrial customers can generally be served from one of several voltage offerings subject to the restrictions found in the preceding section. Commercial and industrial customers can choose to be served at secondary voltage levels, which are shown on the next page for KU/ODP customers. Customers can also choose to be served at primary voltage levels up to 34,500 volts if available. Transmission voltage service up to 161,000 volts is available to KU/ODP largest industrial customers.

Each service voltage class (secondary, primary and transmission) offers different benefits and different sets of customer requirements and responsibilities. Service at secondary levels is a bit more costly than service taken at either primary or transmission levels. However, it places the least burden on the customer in terms of equipment and maintenance costs. The customer does not have to own or maintain high voltage lines or equipment and is not responsible for the equipment necessary to transform high voltage to usable levels. If a service is provided overhead, the service lines are brought right to the building at a usable voltage level.

When service is provided at primary or transmission levels, the customer's monthly utility costs are less, but customer's equipment installation and maintenance costs increase. KU/ODP brings high voltage lines to the customer's property, but terminates its high voltage lines at or near a property line. The customer is responsible for providing and maintaining all high-and low-voltage facilities beyond this point, including transformation and protective equipment.

Choosing a class of service voltage is an important decision for commercial and industrial customers. It is one of the first decisions to be made because it significantly affects the electrical system design for both the customer and KU/ODP. The customer must carefully weigh the benefits and disadvantages, both financially and operationally, of the different service offerings. KU/ODP representatives are available to help customers understand the costs, benefits and limitations involved with each service voltage level.

Unless expressly authorized by KU/ODP, no temporary or permanent electrical work should start until KU/ODP has determined the service size, voltage, wiring configuration and metering requirements. KU/ODP is not responsible for any delays, reconstruction work or additional costs incurred by customers or their contractors/builders if work is started before all of the necessary service parameters have been finalized.

GENERAL INFORMATION

Electric Service Design Parameters *(continued)*

SINGLE-PHASE SERVICE VOLTAGES

Customers requesting the residential class of service will be provided with 120/240 volt single-phase, 3-wire service up to a maximum of 800 amps unless otherwise approved. All new residential services are now required to be a minimum of 100 amps. KU no longer provides 120 volt 2-wire service for any residential customer class. Single-phase service for any non-residential purpose will fall under another class of service. KU standard 120/240 volt single-phase service is available throughout KU electric service territory and can be provided from either overhead or underground lines.

See chart at right for single-phase offerings are available.

THREE-PHASE SERVICE VOLTAGES

Besides being restricted by the presence of existing service equipment, voltage offerings provided by KU may also be restricted based on the size of the service requested and/or the characteristics of the load being served. KU retains the right to designate the service voltage and configuration based on the availability of facilities of adequate capacity and type at the service location.

The three-phase secondary voltages shown below are generally available throughout KU/ODP service territory but may be restricted to either overhead service only or underground service. Not all primary and transmission voltages are available in all parts of KU service territory.

See chart at right for standard KU service offerings.

SINGLE-PHASE SECONDARY SERVICE VOLTAGES	APPLICATION
120/240 volt 3-wire	Residential and commercial services
120/208 volt 3-wire Network	Residential and commercial (where 120/208 volt 4-wire is the nearest source)

THREE-PHASE SERVICE VOLTAGES	APPLICATION
Secondary	
120/208 volt 4-wire grounded wye	Service from either overhead or underground
277/480 volt 4-wire grounded wye	Service from either overhead or underground
120/240 volt 4-wire grounded delta	Service from overhead or underground
Primary	
2,400/4,160 volt 4-wire grounded wye	Restricted Service Area
7,200/12,470 volt 4-wire grounded wye	Restricted Service Area
13,200/22,900 volt 4-wire grounded wye	Restricted Service Area (ODP Only)
34,500/19,900 volt 4-wire grounded wye	Restricted Service Area
Transmission	
69,000 volt 4-wire grounded wye	Restricted Service Area
138,000 volt 4-wire grounded wye	Restricted Service Area
161,000 volt 4-wire grounded wye	Restricted Service Area

GENERAL INFORMATION

Electric Service Design Parameters *(continued)*

CHOICE OF OVERHEAD AND UNDERGROUND SERVICE

Because KU is required by the KPSC to provide service in the least cost manner, service will typically be provided from overhead electric lines and equipment where available unless there is some benefit to KU to do otherwise.

When underground service is specifically requested by a customer and the cost to provide overhead service would be less, the customer is responsible for the difference in cost between

underground and overhead service. KU/ODP also reserves the right to restrict the type of service to either overhead or underground when circumstances necessitate it. For example, underground service may be prohibited in areas subject to flooding and overhead service may be limited at facilities where service cannot be provided safely or reliably from overhead lines and equipment.

OVERHEAD SERVICES

When providing secondary service overhead, KU typically brings service conductors to the home or facility being served although service can be terminated at a customer-owned pole or structure. Service lines will be terminated at a location designated by KU. In overhead installations, KU installs, owns and maintains these service conductors all the way to the home or facility including the electrical connections made at the service entrance. KU is responsible for connecting the customer's wiring to KU/ODP service conductors at the service entrance. The provisions for attaching the service lines to the building or structure are provided by the customer to KU-approved standards. The customer is responsible for all wiring and equipment beyond the

weatherhead with the exception of the electric metering devices.

For industrial and commercial customers taking overhead service at higher voltages, special requirements apply. KU will terminate high voltage overhead lines at or near a property line. Metering equipment will generally be located at or near this point. Beyond this point, the customer is responsible for the distribution and transformation of electrical energy. The customer will provide, own and maintain all electrical equipment, structures, lines and cable systems beyond this point. For additional information, see the section above, "Available Service Voltages and Configurations."

UNDERGROUND SERVICES

Underground Residential Service

When requested by a customer or developer to supply underground electric service, and where in the judgment of KU, such service would be feasible, practicable and in accord with good operating practice, KU will install such underground facilities provided the customer or developer complies with our Underground Practices and Procedures.

In residential subdivisions, KU will install, own and maintain primary and secondary distribution facilities if the developer will provide a trench system and backfill to KU specifications. The trench will be inspected by KU.

Underground residential service from underground or overhead primary or secondary will be installed, owned and maintained by KU for a fee per lot (amount subject to change, see design technician for current costs). As an option, the customer or owner may install the service conduit system, trench and backfill and connect to KU conduit at the property line. KU will install, own, operate and maintain the service system in the applicant-installed conduit. In all cases, the applicant or customer must install the meter base(s).

The point of delivery to an individual premise or load shall be at a point on such premise as designated by KU. The customer or owner will provide, own, operate and maintain all electric facilities on the load side of the point of delivery, with the exception of KU meter for

which suitable provisions shall be made by the customer in accordance with rules and regulations in KU's rate book.

KU/ODP is not obligated to supply underground service when in the judgment of KU such service will be impractical, not feasible or contrary to good operating practices.

Underground Commercial and Industrial Secondary Service

It is seldom feasible to provide service to Commercial and Industrial customers from the property line and KU must extend its facilities onto the customer's property. When this is necessary, the customer must grant an easement and provide all conduit systems, manholes, splice boxes, enclosures, equipment pads and other associated facilities necessary for KU/ODP to extend service onto the property. These facilities must be constructed in strict compliance with KU standards. While the customer provides and maintains these facilities, these facilities remain under the exclusive control of KU and may not be accessed or modified in any way without prior authorization by KU. No facilities from other utilities may be placed in manholes, splice boxes, enclosures, conduit systems, etc. that are provided for KU use. However, KU may allow the customer to place other cable systems in a common trench adjacent to KU conduit system provided the cable systems do not enter manholes, splice boxes, enclosures or conduit systems under the control of the utility. **Water and sewer piping will not be allowed in a common trench.**

GENERAL INFORMATION

Electric Service Design Parameters *(continued)*

For industrial and commercial customers taking underground service at higher voltages, special requirements apply. KU will terminate high voltage cables at or near the property line. Metering equipment will generally be located at or near this point. Beyond this point, the customer is responsible for the distribution and

transformation of electrical energy. The customer will provide, own and maintain all electrical equipment, structures, lines and cable systems beyond this point. For additional information on primary services, see the section above titled *“Available Service Voltages and Configurations”*.

SERVICE LOCATION

Regardless of whether service is provided overhead or underground, at secondary or primary voltage, etc., KU designates the location on the property or on the facility where service will be taken. For overhead services, the service location will usually be the corner of the house or building closest to the KU lines where the service will originate. For underground services, this point is normally an enclosure or a piece of equipment somewhere near the property line closest to KU’s service lines or equipment unless KU has to extend facilities onto the customer’s property in order to provide adequate service.

Overhead service entrances must be located where service can be provided without having to cross over or under another structure, swimming pool, or property not owned by the customer. They must also be located to facilitate proper connections and to provide adequate clearances over roads, drives, structures and the

building being served in accordance with the latest revision of The National Electrical Safety Code (NESC®) and National Electrical Code (NEC®). Underground services must be located such that there are no conflicts with other utilities or other structures, such as buildings or swimming pools.

The meter base should be located on the facility in an accessible location at the point closest to the service entrance unless approval is given to locate the metering equipment elsewhere. For additional information on metering requirements, see Part 2 *“Metering Requirements”*.

KU/ODP representatives will work with the customer to determine the appropriate location for the service entrance and metering equipment.

GENERAL METERING INFORMATION

Because metering requirements can be somewhat confusing and complex depending on the service size/type, a separate section of this handbook, titled Metering Requirements, contains specific information on metering. Standards drawings detailing metering installations can be found in Drawings section of this handbook.

In general, every service installation will require one or more electric meters and the associated meter base(s). The customer is responsible for installing the meter bases. KU provides and installs the electric meter(s) once the service is ready to be energized. Customer is responsible for providing and installing most meter bases. For additional information on meter base requirements, see Part 2 *“Metering Requirements”*.

Regardless of who provides the meter base, the customer installs, owns and maintains the base and other required enclosures for the life of the system. However, the base is considered to be under the exclusive control of the utility as long as the service exists. The meter base will be sealed by KU and access to the meter base is prohibited without authorization.

In addition to meter base requirements, customers may be required to provide additional enclosures and associated equipment for larger single-phase and three-phase services, which require instrument rated metering. All enclosures required to house the special metering equipment and other associated equipment such as connectors, by-pass switches, conduit, structural supports, pads, etc. will be provided, owned and maintained by the customer; they must nonetheless be approved for use by KU before installation. Like meter bases, all metering enclosures, compartments and other associated equipment will be sealed by KU and access to these areas without authorization is prohibited.



GENERAL INFORMATION

Electric Service Design Parameters *(continued)*

EASEMENTS AND CLEARANCE REQUIREMENTS

GENERAL INFORMATION

KU obtains easements whenever it is necessary to locate electric supply lines or equipment on private property. The location of these easements can affect the service location and the cost of the installation. Easements give KU the right to access, construct, operate and maintain electric lines, cable systems and associated equipment used to provide electric service. Often KU electric facilities are located in common easements with other utilities such as gas, telephone, cable TV, etc. The customer shall provide, without cost to KU, satisfactory right-of-way and suitable locations and/or housings for any of KU equipment necessary for supplying service.

The customer continues to own and maintain all property within the easement boundaries and the land is available for many uses. However, easements place restrictions on land use. These restrictions help ensure electric lines are protected, accessible, continue to meet code requirements and can be operated and maintained safely. These restrictions, in part, prohibit the placement of any permanent structures within the easement boundaries. Easements also restrict making any large changes in ground profile that could affect clearance to overhead facilities or burial depth to underground facilities. Easements also restrict the use of land for dumping or extensive storage purposes. These restrictions usually exclude small obstructions, such as fencing not exceeding eight feet, dog houses, gardens, etc., provided they do not obstruct access to poles and equipment. Generally it is permissible to place landscape plantings within easements. However, special restrictions apply to trees planted in easements for overhead lines and for any landscaping placed around ground-mounted electric enclosures. See the section titled *"Landscaping and Vegetation near Electrical Lines."*

Easement restrictions specifically prohibit items, such as buildings and building attachments or extensions (decks, awnings, etc.), garages, large sheds, flag poles, fuel tanks, lighting structures,

swimming pools (above or in-ground), radio/TV antennas, piping systems, signs, large playground equipment, etc. Many times the reason for the easement may not be apparent if electric facilities have been placed underground. Customers should always check property records before placing anything significant on their property. All easement violations will be corrected at the owner's expense. In many cases, easement violations cannot be corrected except by removal of the offending object.

All easements must be obtained before KU can begin installing electrical facilities on private property. The easement and service route must also be cleared of construction materials, dumpsters, dirt piles, trees, fences, etc. before KU begins any work. KU will trim existing trees along its overhead route to provide safe clearances. However, trimming for service lines to the home or building is the responsibility of the customer. The service route is considered to be the area required for KU to run lines to the service entrance point for overhead services and to the customer-utility interface point for underground services.

Any work permits and/or easements required to perform work in public way or to install facilities on property other than the customer being served will be obtained by KU.

Electric easement widths vary according to the characteristics of the electric lines and the nature of nearby obstructions. Typically, easements are taken to provide adequate clearances to all existing obstructions and most common types of future obstructions, such as buildings, signs, etc. However, some special installations that may be added after the lines are in place have clearance requirements that may exceed typical easement dimensions. These include special types of obstructions like swimming pools, grain bins, signs, etc. Some additional information on special easement and clearance restrictions can be found below.

SWIMMING POOLS AND OTHER SPECIAL EASEMENT RESTRICTIONS

For obvious safety reasons, KU does not allow placing a swimming pool anywhere near overhead or underground lines and/or service drops. Pools must never be placed on any utility easements. The NEC® and NESC® electrical codes both have specific requirements for pools that limit how close a pool may be to any electric facility. See Section 7 for NESC® clearance requirements for pools. KU strictly enforces these restrictions.

To be sure there is adequate clearance to meet governing codes, a swimming pool should not be located within twenty-five feet (25') of KU overhead distribution and service conductors, as

measured horizontally from the edge of the pool. Special requirements also apply to pools with diving boards, platforms, slides, etc. Larger distances may be required for clearance to higher voltage lines. Pools should not be installed within five (5) feet measured horizontally, from the edge of the pool or its auxiliary equipment to any underground lines or equipment, including the customer's own underground service line. Customer pool installations must meet the requirements of the latest editions of the NEC® and NESC®.

GENERAL INFORMATION

Electric Service Design Parameters *(continued)*

ADDITIONAL REQUIREMENTS FOR SERVICE LINES

In addition to normal easement restrictions, similar restrictions apply to any overhead secondary service lines serving the customer. Easements are normally not required for these lines because they serve the property owner. Providing and maintaining clear access for the overhead service line is a requirement for

service. While no easement is in place for overhead services, NEC® and NESC® electrical codes prohibit placing many objects under or near overhead service lines. Anything placed under or near the service line, which violates a code, or regulation will be corrected or removed at the owner's expense.

Requirements for Electric Service Equipment

KU frequently has to place poles, guys, and ground-mounted electrical equipment on the customer's property to provide service. As a condition for service, the customer is required to provide and maintain an adequate location and space for any necessary electrical service equipment. The customer may also be responsible for providing protection for utility equipment in the form of fencing, barriers, etc. when necessary to prevent damage from vehicle impacts, the operation of other mechanized equipment nearby or any other activities which present a risk of damage to utility equipment.

The space must be sized to provide necessary clearances, oil containment and lighting while conforming to safety codes and KU specifications. No customer or third-party items of any kind are to be attached to KU facilities or customer facilities under the control of KU without prior written permission from the company.

ACCESS AND CLEARANCE TO KU/ODP SERVICE EQUIPMENT

Access to metering and supply equipment owned or controlled by KU must be available during normal working business hours (8:00 a.m. – 5:00 p.m. Monday-Friday) and all other reasonable times as may be required to install, remove, operate and maintain service-related equipment. Access must also be provided at any time for the purpose of dealing with service outages, equipment damage, and to correct any type of safety hazard or address any other type of emergency. The customer shall not construct or permit the construction of any structure or device that will restrict KU access to its equipment for any reasonable purposes.

available to work with customers to avoid any conflicts between KU equipment and customer facilities or landscaping.

In general, a minimum of six feet of clearance in front of and two feet to each side of electric meters is required for reading and maintaining electric meters. Larger clear space requirements are necessary in front of other types of metering enclosures with large doors or covers. Adequate clear space on the sides, above and below such enclosures must be provided such that the enclosure covers/doors can be fully opened and/or covers removed so that the internal equipment can be worked on safely. Removable doors, where permitted, must be of a size and weight suitable for handling safely by a single person.

It is KU policy not to take possession of customer keys. If metering or other service supply equipment must be placed in a lockable location, acceptable and agreed upon provisions to access the equipment must be provided. A double locking system or lockable boxes that allow KU access, for example, may be required. Electronic locks present a problem and an agreed upon access arrangement is required between the utility and the customer. KU service representatives will assist with the location and selection of lockable boxes.

Clear space around other ground-mounted equipment is also required and varies by the type of equipment and the voltage involved. In general, a minimum of 6' from the sides and back of any pad-mounted equipment is required. Clear space requirements increase to as much as 10' in front of high voltage pad-mounted equipment containing a door or cover. Contact your KU service representative for specific clearance information.

Structures and other obstructions near KU electrical equipment can jeopardize the safety of KU employees and contractors working on and around electrical equipment. Customers should not place any landscaping, fences, sheds or any other structural obstruction near metering equipment or other ground-mounted electrical equipment. Minimum clear space requirements vary by the type of equipment or enclosure involved. KU representatives are

KU employees and contractors are authorized to remove any obstruction that interferes with safely working on or around its electrical equipment. KU is not responsible for damage to the customer's landscaping or other structural obstructions that interfere with the ability of its employees or contractors to work safely.

GENERAL INFORMATION

SPECIAL EQUIPMENT REQUIREMENTS

EQUIPMENT VAULTS

Where practical all KU service facilities, including transformers and switchgear are to be placed outside of buildings and other structures. KU may waive this requirement if the only space available for placing the equipment is inside a building or underground in an enclosure such as a fireproof vault. In these cases, the customer must construct suitable housing for the equipment. The structure must have adequate size, ventilation, oil retaining capacity and lighting to conform to building codes, safety codes and KU specifications. It must also meet all applicable fire codes and be approved by the Authorized Inspection Authority.

When vaults are required, customers will secure vault specifications from KU and consult KU regarding the location and construction of equipment vaults while building plans are being prepared.

Vaults or rooms shall be so located as to be easily accessible by direct entry from outside the building, for the purpose of installation,

maintenance and removal of KU equipment. Vaults must be of fireproof construction, be adequately ventilated and drained, and shall comply in all respects with the NEC® and any other applicable codes.

Transformer vaults will contain only transformers, switchgear and other electrical service-related equipment. All customer equipment, including secondary fuses, switches, circuit breakers and KU meters will not be installed in transformer rooms and vaults. Customer access to these locations is prohibited unless approved by KU. If access is necessary, a KU representative is required to be present at any time access is needed. KU reserves the right to recover the cost of providing a representative for this purpose.

KU reserves the right to serve other customers from its equipment located in vaults on the customer's premises, provided this does not interfere with the customer's service.

SPECIAL REQUIREMENTS FOR OIL-FILLED TRANSFORMERS

Even when padmount transformers and other types of oil-filled equipment are placed outside special restrictions apply to where they can be located in proximity to buildings. In addition to access considerations, requirements restrict how close oil-filled equipment can be placed to buildings. Details on these requirements can be found on Standards Drawing # 42 06 20 in Drawings section of this handbook.

These guidelines permit oil-filled equipment to be located closer than normal minimum requirements if other steps are taken to reduce the fire potential of the installation. Depending on the type of building involved, clearances may be reduced by using a combination of barrier walls, oil retention pit and/or fire rated roof over equipment. Please note that the oil retention pit does not qualify as oil containment under environmental regulation purposes. It is strictly to reduce the potential for spreading burning fluids in the event of a catastrophic failure.



METER INFORMATION

CONTAINS FCC ID: R7PEQ1R156

CONTAINS IC: 5264A-ED1R156

Landis
Gyr

GRIDSTREAM RF
90E4D73C



MODULE MODEL:
SE 10095960 FOCUS RXR



ZigBee
Certified product

Va
DEL
DEL
A
000000
000000 kWh
240

Type **FOCUS RXRe-SD**
FORM 2S CL200 240V 3W 60Hz TA=30 Kh 7.2

KU

1009596



NXA001009596LTL11

METER INFORMATION

This section contains specific information related to electric metering. Part seven of this handbook contains the accompanying meter-related drawings. Metering requirements vary by class of

service and the characteristics of the installation. KU service representatives will work with the customer or contractor to determine the necessary requirements.

Requirements for Electric Service Equipment

KU/ODP-PROVIDED METERING EQUIPMENT

KU/ODP provides the electric meter(s), instrument rated transformers and meter-related control wiring required for the purpose of revenue metering for permanent services. The customer is responsible for the installation of all other metering related equipment, including KU/ODP-provided meter bases, instrument transformers and other enclosure systems required for metering. KU/ODP will install the electric meter and any related meter wiring once customers have met all of their requirements for electric service.

The contractor is responsible for protecting meter bases, metering transformers and other associated equipment provided by KU/ODP against loss, damage and theft. It is the customer's responsibility to notify KU/ODP should service no longer be needed. KU/ODP will then disconnect service and retrieve the meter and, if applicable, instrument rated transformers.

METER BASES

KU/ODP provides meter bases for **single-phase and three-phase temporary and permanent services larger than 400 amps**; these installations require instrument transformers and special bases. The customer provides all other meter bases for temporary services.

Customers must provide their own single-phase self-contained meter base for 400 amp and below. (KU/ODP will provide bases

for all instrument rated metering installations.) All customer-provided meter bases must be approved for use by KU/ODP. Drawings section of this handbook contains an approved listing of bases that are available from local suppliers within KU/ODP service territory. KU/ODP reserves the right to decline service if the customer installs an unapproved meter base.

The customer is responsible for providing a KU/ODP-approved meter base for single-phase permanent and temporary services 400 amp and less, and for three-phase temporary services 400 amps and less. Approved bases for single-and three-phase services can be purchased from suppliers in the KU/ODP service territory. KU/ODP does not provide any multiple (ganged) metering assemblies.

CURRENT AND POTENTIAL TRANSFORMERS

KU/ODP provides any instrument rated transformers for metering larger single-phase and three-phase services. However, the customer or electrical contractor is responsible for installing the secondary transformers (600V or less). Primary instrument transformers (voltages greater than 600V) will be

installed by the Electric Meter Department. KU's Electric Meter Department issues the Instrument transformers to the customer or contractor provided the customer has submitted the necessary service load data on the current *Electrical Load Data Submittal Sheet*.

SPECIAL METERING ENCLOSURES AND EQUIPMENT

In addition to meter bases, larger services may also require additional compartments, enclosures, equipment supports, conduit, etc. to house instrument transformers and other associated metering equipment and wiring. Compartments to be provided by the customer include instrument transformer cabinets, switchgear metering compartments, primary metering compartments and any other special enclosures.

The customer is required to provide and install any special equipment such as bypass switches, special connectors and surge protection equipment if required. KU/ODP will provide control wiring for instrument transformers. The customer is to complete all other wiring. The customer must provide and install enclosure systems and equipment to KU/ODP specifications. (See Drawings section for detail drawings.)

METER INFORMATION

GANGED METERING

Customers must provide multiple (ganged) metering assemblies which, are typically used for multiple-tenant facilities. Special requirements apply and customers must work closely with the KU/ODP representative and the Electric Meter Department

to ensure they meet all the requirements for service. All such equipment must be pre-approved before purchase and installation. KU/ODP reserves the right to decline service if the customer installs unapproved equipment or enclosures.

OWNERSHIP AND CONTROL OF EQUIPMENT

KU/ODP retains ownership of the electric meter(s) as well as, any applicable instrument transformers and associated wiring. Metering installations must not be modified or moved by anyone other than an authorized representative of KU/ODP.

regardless of the reason for replacement. Additionally, the appropriate Authorized Inspection Authority must permit, inspect and approve the electrical work.

Customers own and maintain all meter bases regardless of whether the customer purchases the bases or KU/ODP provides them. Customers also own and maintain any other required metering compartments, enclosures and associate equipment. In the event the meter base or other enclosure has to be replaced due to failure, damage or rewiring work, the customer will be responsible for the total cost of replacement, including in some cases, the cost of a new meter and/or base. A qualified electrical contractor should complete the replacement of the meter base

All meter bases, enclosures and compartments are under the exclusive control of KU/ODP and will be sealed by KU/ODP for safety and security. Access to the meter base or any other sealed enclosures without authorization from KU/ODP is prohibited.

The matrix below is a summary of who provides, installs, owns and controls each component of the metering systems. Maintenance of any component is the responsibility of the component owner.

RESPONSIBILITY MATRIX FOR METERING EQUIPMENT

ITEM	PROVIDE	INSTALL	OWN	CONTROL
Electric Meters (All, Permanent and Temporary)				
Electric Meters	KU/ODP	KU/ODP	KU/ODP	KU/ODP
208V & 240V Meter Bases (All, Permanent and Temporary)				
Up to 400A—Self-Contained Meter Base	Customer	Customer	Customer	KU/ODP
Greater Than 400A—Instrument Rated Meter Base	KU/ODP	Customer	KU/ODP	KU/ODP
480V Meter Bases (All, Permanent and Temporary)				
Up to 200A				
Self-Contained Meter Base*—Requires Disconnect	Customer	Customer	Customer	KU/ODP
Greater Than 200A—Instrument Rated Meter Bases	KU/ODP	Customer	KU/ODP	KU/ODP
Meter Related Equipment				
Meter Base Connectors and Hubs	Customer	Customer	Customer	KU/ODP
Current/Potential Transformers—Instrument Rated Metering	KU/ODP	Customer**	KU/ODP	KU/ODP
Metering Transformer Wiring—Instrument Rated Metering	KU/ODP	KU/ODP	KU/ODP	KU/ODP
Meter Compartments—C.T. Cabinet, etc.	Customer	Customer	Customer	KU/ODP
Metering Compartment Connectors	Customer	Customer	Customer	KU/ODP
Conduit for Meter Related Wiring, Meter Stands, etc.	Customer	Customer	Customer	KU/ODP
Meter Supports, Pads, Pedestals, Etc.	Customer	Customer	Customer	KU/ODP
Meter Bypass Switches—When Required	Customer	Customer	Customer	KU/ODP
Source Side Load Break Disconnect 480V Metering*	Customer	Customer	Customer	KU/ODP

* 480V self-contained metering requires a source side non fused load break disconnect installed by the customer in accordance with 2020 NEC 230.82. The switch is provided, owned and installed by the customer but is controlled by the utility so that the meter may be removed safely with the service de-energized. The switch does not meet the requirements for a main service disconnect for the service because it under the control of the utility.

** For primary and transmission voltage KU/ODP installs

METER INFORMATION

Obtaining Meter Bases And Associated Equipment

KU/ODP does not provide meter bases except where outlined above. For these instances, meter bases can be obtained between the hours of 8 a.m. and 3 p.m. from KU's Electric Meter Department at:

Nearest KU Operation Center
Contact KU Service at 1-800-981-0600

ODP will deliver meter bases to the customer when the spot service order is worked.

Approved three-phase meter bases below 200 amps and greater than 200 amps through 400 amps (240V maximum) can be purchased from suppliers in the KU/ODP service territory.

The following instructions apply when obtaining metering equipment from KU/ODP: For all three-phase meter installations,

no base, current transformers or potential transformers will be issued before a KU/ODP representative reviews and approves the project's design. KU/ODP uses load information provided by the customer on the current Electrical Load Data Submittal Sheet to specify electrical metering systems. The KU/ODP representative will provide the regional Meter Shop Coordinator with the designated service location and estimated maximum expected demand, and, if requested, the service entrance size based on the information provided.



Installation Of Metering Equipment

LOCATION OF METERING

The customer is responsible for providing and maintaining an approved location for the installation of metering equipment, including the metering systems, current transformers, potential transformers, test devices and related enclosures.

All meter bases should be installed outdoors in easily accessible, secure and non-hazardous locations approved by KU/ODP. The locations must be free from obstructions, corrosive hazards, extreme temperatures and excessive vibration. Meter bases

shall not be installed on or below decks. When it is impossible or impractical to install the meter base outside, KU/ODP may approve the installation of the electric meter base in a secure, non-hazardous, accessible indoor location. Approval to install metering equipment indoors must be granted prior to placement of the equipment. It will be the customer's responsibility to relocate any metering equipment not installed in an approved location.

CUSTOMER-FURNISHED EQUIPMENT REQUIREMENTS

All meter bases, metering transformer cabinets and all other enclosures and equipment, including any connector systems the Customer provides must be listed for its intended application by a recognized testing organization such as UL®. Enclosures and compartments intended for outdoor use must meet the minimum requirements of NEMA® 3-R. Such equipment when mounted indoors must meet a minimum of NEMA® 1 requirements. Customer-provided connectors not specified by KU/ODP must

be clearly marked with the intended conductor size and conductor type (copper and/or aluminum).

All meter bases, metering transformer cabinets and all other enclosures and switchboxes installed for metering must be equipped with provisions to accept a KU/ODP meter seal. All compartments and enclosures other than the meter base must have provisions for padlocking.

INSTALLATION REQUIREMENTS

No disconnect means will be allowed in front of the electric metering point except by special authorization of KU/ODP or when required by the NEC® and approved by KU/ODP. No junction boxes, splice boxes, panels or other compartments, etc. will be allowed ahead of the electric metering point without approval of KU/ODP unless they are intended for the purpose of housing metering equipment and under the exclusive control of KU/ODP.

All meter bases, enclosures and compartments must be installed level, plumb and securely fastened to walls or other

supports. Customers are responsible for installing equipment in compliance with all relevant KU/ODP standards and in a manner that protects the metering devices from loss, damage and theft both during construction and while in service.

All meters are to be mounted such that the meter centerline height is 5'-6" above finished grade. If this height cannot be obtained while meeting other location requirements, the meter can be located between 4'-0" and 6'-0" above finished grade. When special circumstances do not permit this mounting height,

METER INFORMATION

KU/ODP may allow a deviation in the mounting height requirement, but in no case will meters be mounted above 6'-0" above finished grade or less than 4'-0" above finished grade.

The working space directly in front of all metering equipment must be at least 48" wide (2'-0" on either side of the meter) and 6' deep measured from the front of the meter. Contact the KU/ODP representative assigned to your project should the need exist for deviations from these rules.

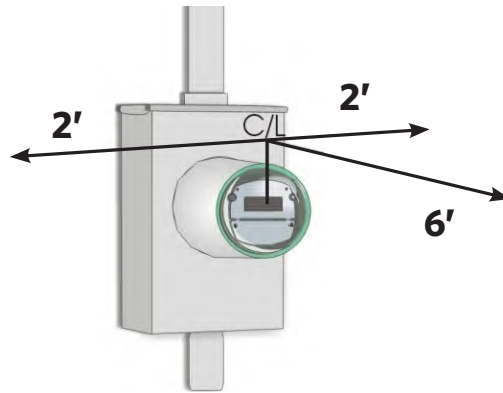

SPECIAL REQUIREMENTS FOR MULTI-METER INSTALLATIONS

All grouped or multiple meter equipment must be approved by KU/ODP Distribution Operations Center prior to installation. Only one customer is to be metered from a given service. Meters at these sites must be a ring-less type with by-pass horns.

When multiple meters are installed at a site, each service to the premise must be uniquely identified with a tag or label in a permanent manner to identify which portion of the premise is served. Placing tags or labels on lids that can be inadvertently interchanged is not acceptable. When the premise is served from a trough system or by multiple individual services, labels should be installed in a visible location on the side of the base.

For ganged meters, labels should be placed on main disconnect if it is immediately adjacent to the meter. If no other form of labeling is possible, one label must be affixed to the lid and another matching label placed inside the meter base in a visible location. See KU Standard Drawing # 81 20 03 found in Drawings section.

The customer's name is not acceptable premise identification. The labels must be either engraved nameplates or adhesive-type labels at least one-half inch high. Felt-tip pens and label maker tape is not considered permanent marking. Service will not be established until marking is complete.

METER REMOVAL

KU/ODP sometimes receives requests to remove self-contained meters so customers can repair or modify internal wiring. Only qualified personnel, authorized by KU/ODP, are permitted to cut seals and remove meters. The company may grant exceptions to qualified electricians for emergency work. Contact the KU/ODP Customer Service department at 1-800-981-0600. KU/ODP must be promptly notified when repairs or modifications have been completed.

Never remove an instrument-rated meter under any circumstance. Removal of an instrument-rated meter will not provide a break in the incoming service and extremely high voltages will develop in the meter base and associated instrument transformer wiring if the meter is improperly removed.

Removing the meter also does not guarantee the service cannot remain energized by another energy source, such as a standby generator, Uninterruptible Power Supply (UPS) system, etc. Any party that removes a meter, whether authorized or not, accepts all liability for damage or alteration to equipment, injury to persons or property, and loss of revenue from the time the seal is removed until 72 hours after KU/ODP has been notified that the meter is ready to be resealed.

All meter sockets must be covered and sealed with a transparent cover at any time a meter is not installed for any reason. Unused meter bases must also be sealed with a transparent cover.

Extreme caution must be used when meters are removed or installed.

Never remove meters until the source has been disconnected or all loads beyond the meter have been disconnected or otherwise shut off. Manufacturers do not design meters to interrupt load, and damage to the metering equipment and/or personal injury could result if the meter is removed under load.

METER INFORMATION

INDEX OF METER-RELATED DRAWINGS

The following matrix details the meter applications and the appropriate reference standards. Each of the referenced drawings can be found in Drawings section of this handbook.

REFERENCE DRAWINGS FOR RESIDENTIAL AND COMMERCIAL METERING REQUIREMENTS

SERVICE VOLTAGE	SERVICE AMPACITY	APPLICABLE STANDARD DRAWING	
120/240V 1Ø 3-Wire OR 120/208 (Network) 3-Wire**	0 to 200 Amps	1 Conductors Max./Ø	81 20 10*
	>200 to 400 Amps	2 Conductors Max./Ø	81 10 41 and 81 20 02
	>400 to 800 Amps	2 Conductors Max./Ø	81 10 02*
120/240V 3Ø 4-Wire Grounded Delta	0 to 200 Amps	1 Conductors Max./Ø	81 20 10*
	Over 200 Amps		81 20 02
120/208V 3Ø 4-Wire Grounded WYE	0 to 400 Amps	2 Conductors Max./Ø	81 20 10
	>400 to 800 Amps	2 Conductors Max./Ø	81 10 07
	>800 to 2000 Amps	5 Conductors Max./Ø	81 0 12
	Over 2000 Amps		See Area Design Tech./Engineer
277/480V 3Ø 4W Grounded WYE	0 to 200 Amps	2 Conductors Max./Ø	81 20 10
	>200 to 800 Amps	2 Conductors Max./Ø	81 10 07
		4 Conductors Max./Ø	81 10 08
>800 to 2000 Amps	5 Conductors Max./Ø	81 10 12	

* Refer to Standard Drawing 81-10-40 for additional requirements on self-contained meter bases.

** Requires special meter base with 5th lug.

METER INFORMATION

The following table also details other meter installation drawings of interest.

ADDITIONAL DRAWINGS FOR 1-PHASE RESIDENTIAL AND COMMERCIAL SERVICE INSTALLATIONS

SERVICE VOLTAGE	SERVICE AMPACITY	APPLICABLE STANDARD DRAWING		
		Meter Socket	Overhead	Underground
			All	All
120/240 Volt 1-Phase 3 Wire	0 to 200 Amps	81 20 10*	81 20 02	52 01 00
	Over 200 Amps to 400 Amps	81 20 02 and 81 1 41		See Area Design Tech.
	Over 400 Amps to 1200 Amps	81 10 02* and 81 20 10*	81 10 02	

* Refer to Standard Drawing 81-10-40 A for additional requirements on self-contained meter bases.



METER INFORMATION

LIST OF APPROVED METER BASES

Service Type—Single-Phase 120/240 Volt, 2 / 3 wire	MANUFACTURERS	CATALOG NUMBERS	
125 Amp Overhead/Underground	Milbank	U7487-XL-TG-KK	
	Durham	UHT-RS101B	
	Siemens	UAT111-OPZ	
	Siemens	UAT111-OPQG	
	Eaton	UHTRS101BCH	
225 Amp Overhead/Underground	Brooks	601U43W1B41-B20A00	
	Milbank	U7040-XL-TG-KK	
	Durham	UHT-RS212B	
	Siemens	UAT417-OP	
	Siemens	UAT417-XPQG	
	Lever Bypass	Eaton	UTE4213TCH
	Eaton	UHTRS213BE	
320 Amp - Overhead	Milbank	U1079-R, U2448-X	
	Durham	UT-H4300T	
	Siemens	47704-01	
	Siemens	47604-02	
	Siemens	47704-01NU	
	Eaton	UTH4336TCH	
320 Amp - Underground	Milbank	U1129-O-K3L-K2L, U1797-O-K3L-K2L, U2448-X	
	Durham	UT-H4330U	
	Siemens	44704-01	
	Siemens	48704-82GP	
	With 200 Amp Main(s)	Siemens	MC0816B1400RLTM
		Eaton	UTH4336TCH

Catalog numbers do not reflect Hub Size or Cover Plates.

Catalog numbers for 320 Amp bases do not include wire termination lugs.

Bases must be UL-listed, have bypass capability and be of the ringless design.

Please call for requirements on any services not listed above:

KU/ODP

Customer Service

1-800-981-0600

METER INFORMATION

Service Type—Three Phase	Manufacturers	Catalog Numbers
125 Amp—Overhead / Underground None Approved—Use 225 Amp		
225 Amp Overhead/Underground		
5 Terminal	Eaton	UTH5213BNDCH
7 Terminal	Eaton	UTH7213UCH
7 Terminal (KU/ODP-Furnished)*	Talon*	40407-0250
5 Terminal ((KU/ODP-Furnished)**	Talon**	9804-8592
5 Terminal	Milbank	U9581
7 Terminal	Milbank	U9701-RRL
320 Amp Overhead/Underground		
5 Terminal (208V 3W Wye Network Only)	Eaton	UTH5330UCH
7 Terminal (120/208 Wye Only)	Eaton	UTH7330UCH
5 Terminal (208V 3W Wye Network Only)	Siemens	47705-02
7 Terminal (120/208 Wye Only)	Siemens	48707-02
5 Terminal (208V 3W Wye Network Only)	Milbank	U4419
7 Terminal (120/208 Wye Only)	Milbank	U2120X or U2594X

Catalog numbers do not reflect Hub Size or Cover Plates.
 Catalog numbers for 320 Amp bases do not include wire termination lugs.
 Bases must be UL-listed, have lever bypass capability and be of the ringless design.
 *7 Terminal Bases for : 240V 4W Delta 120/208V 4W Wye and 277/480V 4W Wye
 **5 Terminal Bases for: 208V 3W Wye Network

Please call for requirements on any services not listed in these charts.
 KU/ODP
 Customer Service
 1-800-981-0600

Service Type—Single and Polyphase Multi-Centers	Manufacturers	Catalog Numbers
125 Amp—Overhead / Underground		
2 Gang	Eaton	UHT2R112BCH
Single-phase	Siemens	WMM32125RJB, WMM42125RJB, WMM52125RJB, WML13100RJ, WML23100RJ, WML33100RJ
Polyphase - 7T	Siemens	WML43100RJ
225 Amp Overhead/Underground		
2 Gang—Single-phase	Eaton	UHT2R2332TCH
	ABB	TMPR312422R
Polyphase - 7T	Milbank	U1252-RRL-KK-K1
2 Gang—Single-phase	Siemens	WMM32225RJB, WMM42225RJB, WML13225RJ, WML23225RJ
Single-phase Polyphase - 7T	Siemens	WML33225RJ, WML43225RJ
320 Amp Overhead/Underground		
Non-Approved	Non-Approved	

Centers must be UL-listed, have bypass capability and be of the ringless design.

TEMPORARY & PERMANENT SERVICES



TEMPORARY & PERMANENT SERVICES

Temporary Services 600 Volts or Less

Temporary electric service is defined as a means of supplying electric service to a site for **less than one year**. The most common use for a temporary service is to provide power to a construction

site until provisions can be made for permanent service. KU/ODP's service representatives will work with customers to identify all associated costs.

TEMPORARY SERVICE CHARGES

The minimum charge for a single-phase, overhead or underground temporary service shall be based on the size of the service and the equipment required. The minimum charges for temporary, single phase, overhead service drops made from existing transformer installations are available from your KU/ODP service representative. The minimum charge for a temporary service, requiring the installation of a transformer and a service drop, from an existing primary and pole and removal of these facilities when the temporary service is no longer needed, will be supplied by the KU/ODP service representative and is to be paid in advance. Temporary services not covered by one of the above will be installed for the customer with the charge based on the estimated up and down charge for the service. The total amount of this estimated cost is to be paid prior to the installation of the temporary facilities. In addition to the above-mentioned charges, there is an additional charge for each time KU is called out by the customer to connect or disconnect a temporary service but is unable to perform this work because the customer is not ready for the service to be connected or disconnected, the service entrance does not meet KU standards and/or, when required, the service has not been inspected.

To begin the process, the customer must follow the same procedures to apply for temporary service as they would for permanent service. The first step toward arranging for service is to follow the guidelines in the section entitled "Applying for Electric Service." The customer must contact KU/ODP and complete an application for electric service. The form can be

completed online, lge-ku.com, or at KU/ODP offices or by phoning **1-800-981-0600**. All other steps in the section, "Steps for Obtaining Electric Service" must also be followed. A separate application of service is required for temporary service, although applications for temporary and permanent service can be processed at the same time. An electrical inspection at the construction site by the Authorized Inspection Authority is required prior to notifying KU/ODP to install the meter and activate the service. KU/ODP must also approve the installation prior to connecting the temporary service to ensure the safety of KU/ODP employees who are working to complete your service request.

The requirements in this section cover only routine installations. Special requirements may apply for unusual or non-standard applications. For example, special requirements may apply where the distance from KU/ODP's serving facilities is great or ground clearance or other circumstances necessitate special requirements. The customer is responsible for protecting meters and metering transformers and other associated equipment provided by KU/ODP against loss, damage and theft.

The customer should notify KU/ODP as soon as the service is no longer needed. KU/ODP will then close the customer's account, disconnect and remove the temporary service and any unneeded service equipment and retrieve the electric meter and associated equipment.

AVAILABLE SERVICE

Details in this section cover single-phase and three-phase provisions for temporary secondary services, typically 480 volts and below. Higher voltage temporary service may be provided, if requested; however, each installation will require a special design and equipment. The most common temporary service is a 120/240 volt, 1-phase, 3-wire service. All single-phase services must be wired for three-wire service regardless of need.

Two-wire service is no longer provided. The chart below shows available electric service ratings for single-phase, 120/240 volt temporary services. Transformer rated metering will be necessary for services larger than 400 amps and additional requirements apply. Contact your KU/ODP representative for information on the additional requirements or when temporary service is requested at voltages other than 120/240 volt, 1-phase, 3-wire.

TEMPORARY & PERMANENT SERVICES

Temporary Overhead Services

CLEARANCE REQUIREMENTS

The National Electrical Safety Code (NESC®) and the National Electrical Code (NEC®) have established minimum overhead clearance requirements to ensure safe heights for different types of electrical conductors over various terrains depending on the type of usage expected. The diagram illustrates ground clearance requirements for a typical overhead temporary electric service. For additional information, refer to the latest NESC® and/or NEC® codes. Your electrical inspector and KU/ODP service representative will be able to assist you to design a temporary service support so adequate clearance is provided. Although KU/ODP provides the overhead service conductors, the customer must provide adequate clearance at the temporary structure to ensure all applicable clearance requirements can be met.

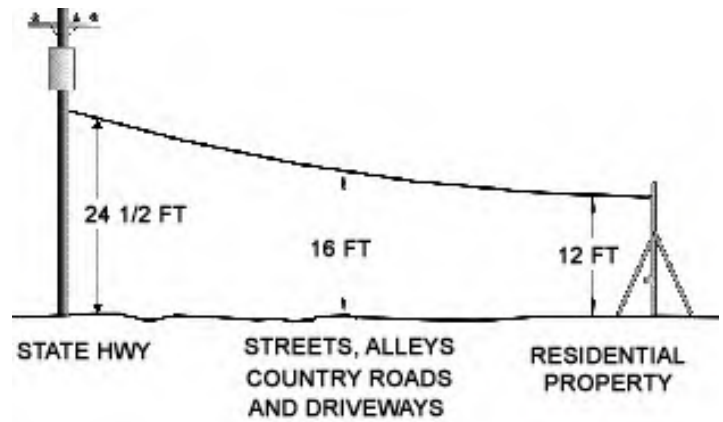

RESPONSIBILITIES

Customer-Owned and Installed Equipment

(All Equipment Installed to KU/ODF Specifications)

- Post, Bracing and Cable Attachment Provisions
- Meter Base and Service Disconnect
- Service Entrance Conductors (Weatherhead and Beyond)
- Ground Conductors, Rods, etc.

Notes

- Timber sizes for service supports found in the standard drawing # 12 10 02 in Drawings section of this handbook are recommended as the minimum for the strength required. KU/ODP assumes no responsibility for failure of support caused by the attachment of its service.
- 2020 NEC® Article 590.6 requires approved ground-fault circuit protectors on all 15, 20 and 30 amp single-phase receptacle outlets.
- Service neutral and meter base must be permanently grounded in accordance with NEC® guidelines.

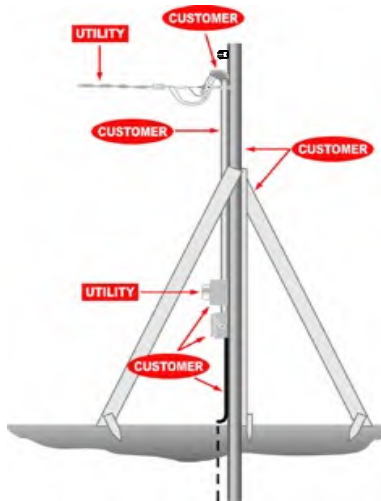

KU/ODP-Owned and Installed Equipment

- Utility Service Lines (to Weatherhead on Customer's Structure)
- Connection to Customer Wiring
- Electric Meter and Metering Transformers, if applicable

Note: Instrument transformers, if required, will be provided by the utility but installed by the customer. The utility will provide and install any associated meter wiring.

OVERHEAD TEMPORARY SERVICE LOCATION

For services up to 200 amps, a temporary meter/termination post should be located on the Customer's property and **within 75 feet** of the utility pole for services that will serve the site. Contact a KU/ODP Service Locator before construction begins (1-800-981-0600) if it is not obvious which utility pole will be used to provide service to the site or if the service distance will exceed 75 feet. Additional costs may be involved for distances exceeding 75 feet. Larger single-phase and three-phase temporary services are available, if necessary, but special requirements will apply. Contact the KU/ODP representative for additional information.

CONSTRUCTION STANDARDS

All overhead temporary services are to be constructed in accordance with KU/ODP Standard Drawings # 12 10 02 found in Drawings section of this handbook. Another drawing that may be useful in the construction of underground temporary services is the meter base detail # 81 20 10 shown in Drawings section of this handbook.

TEMPORARY & PERMANENT SERVICES

Temporary Underground Services

BURIAL REQUIREMENTS

The National Electrical Safety Code (NESC®) and the National Electrical Code (NEC®) have established minimum burial depths for the safe installation of underground electrical conductors for all wiring methods and all types of terrain. The customer's service must be brought to within 18" of a splice box or transformer, as required. Sufficient slack, as shown on the standards # 52 10 02, must be left such that KU/ODP can connect the service. KU/ODP will make the connection to the customer's cable and activate service once all of the requirements for service have been met and KU/ODP is notified that the customer is ready for service.

The customer must ensure the burial depth meets code requirements at all times and is sufficient to protect the service conductor from damage imposed by expected surface usage and/or changes in grade. For additional information on burial requirements, refer to the latest edition of the NESC®, NEC® or contact the Authorized Inspection Authority.

If you are in one of the counties below, call 8-1-1 or visit Kentucky811.org.

Anderson	Fayette	Jessamine	Oldham
Bourbon	Franklin	Madison	Scott
Boyle	Grant	Mercer	Shelby
Clark	Harrison	Montgomery	Woodford

If you are in a county **not listed** above, contact both KU and Kentucky 811.



RESPONSIBILITIES

Customer-Owned and Installed Equipment

(All equipment installed to KU/ODP specifications)

- Service support (post or pedestal) and bracing
- Meter base and disconnect
- Service entrance conductors
- Service line and conduit to the transformer or splice box
- Ground conductors, rods, etc.

Notes

- 2020 NEC® Article 590.6 requires approved ground-fault circuit protectors on all 15, 20 and 30 amp single-phase receptacle outlets
- Service neutral and meter base must be permanently grounded in accordance with NEC® guidelines.

KU/ODP-Owned and Installed Equipment

- Transformer or pedestal
- Utility secondary lines to customer's point of ownership (for service from pedestal)
- Connection to customer wiring
- Electric meter and metering transformers, if required

Note: Instrument transformers, if required, will be provided by the utility, but installed by the customer. The utility will provide and install any associated meter wiring.

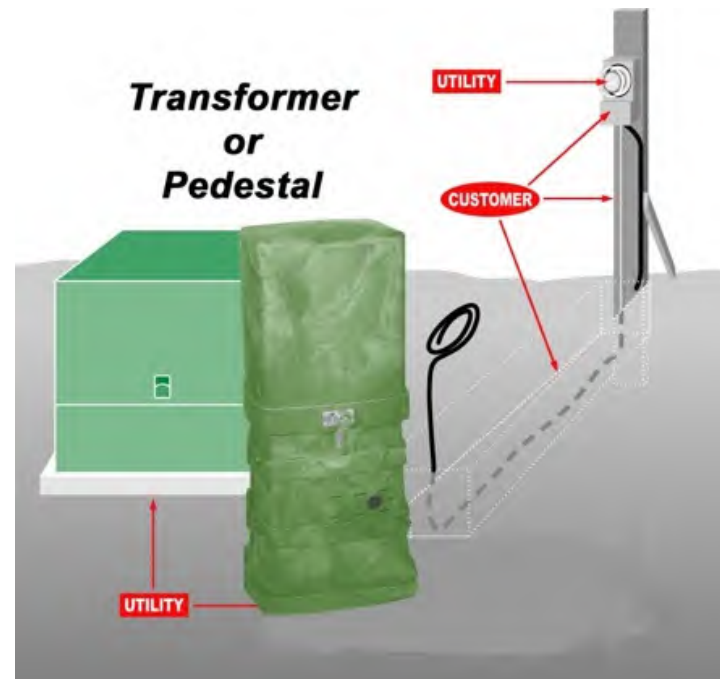

CONSTRUCTION STANDARDS

All Underground temporary services are to be constructed in accordance with KU/ODP Standard Drawings # 52-10-02 found in Drawings section.

TEMPORARY & PERMANENT SERVICES

Temporary Underground Services *(continued)*

UNDERGROUND TEMPORARY SERVICE LOCATION

All residential lots with underground electric facilities will have either a transformer or a service pedestal located adjacent to one of the property lines. In rare cases, a lot may have both a transformer and a service pedestal located along property lines. The Temporary Service structure should be located in the following manner:

1. Whenever a transformer is located along either property line, locate the temporary structure on the side of the lot closest to the transformer and run the service conductors to within 18" of the secondary side of the transformer. (See note 1)
2. If both a transformer and splice box are present, locate the temporary structure on the side of the lot closest to transformer and run the service conductors to within 18" of the secondary side of the transformer. (See note 1)
3. If only a splice box is present, locate the temporary structure on the side of the lot closest to the splice box and run the service conductors to within 18" of the splice box.

Note 1: The secondary side of the transformer is located on the right-hand side when facing the front of the transformer.

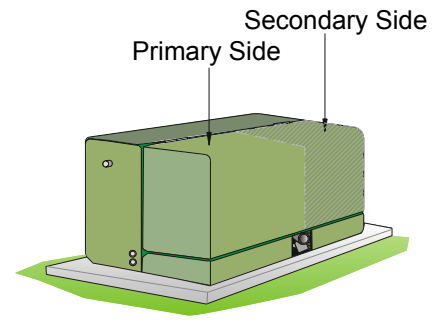

If there is neither a transformer nor a pedestal, call the appropriate KU/ODP representative. All structures used for temporary service should be located outside of the equipment clear working zone as shown in the detail below. Contractors should use care not to route temporary service conductors across or along the path intended for the permanent service conductors.

Temporary electric services for underground installations are to be constructed in accordance with KU/ODP Standard Drawing # 52 10 02 shown in Drawings section of this handbook. Another drawing that may be useful in the construction of underground temporary services is the meter base detail # 81 20 10 shown in Drawings section. **Note:** Instrument transformers, if required, will be provided by the utility, but installed by the customer. The utility will provide and install any associated contact meter wiring.

Please be aware of KU/ODP's requirements for a clear work zone area around utility equipment for temporary service structures. Temporary service structures should be located out of the reserved work zone area.

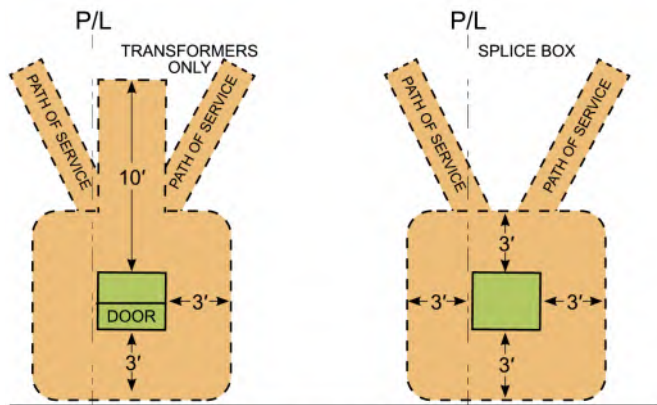

Please be aware of KU/ODP's requirements for a clear work zone area around utility equipment. Service structures should be located out of the reserved work zone area.

ROAD R/W OR REAR PROPERTY LINE

Equipment Clear Working Zone

TEMPORARY & PERMANENT SERVICES

General Information for Permanent Residential Service

This section applies to permanent residential service for most Single-Family Residences, Multi-Family Structures and Mobile Homes.

To begin the process for permanent service, the customer must follow the procedures in the section entitled, "Applying for Electric Service." The customer must contact KU/ODP and complete an application for electric service. The form can be completed online, **lge-ku.com**, or at **KU/ODP offices** or by phone at **1-800-981-0600**. A separate application is required if temporary service is needed prior to the installation of the permanent service, although applications for temporary and permanent service can be processed at the same time. (For information on temporary service, see the section titled, "Temporary Services 600 Volts Or Less".) The customer must also follow all other steps in the section, "Steps for Obtaining Electric Service".

Because the design of a permanent service is far more involved than temporary service, customers should review the sections titled, "General Information" and "Meter Information" and the section that deals with the type of facility being served prior to finalizing the design of the electric service.

The requirements in the following sections cover only routine installations. Special requirements may apply for unusual or non-standard applications. For example, special requirements may apply for larger home services or services where the distance from KU/ODP's serving facilities are great or ground clearance or other circumstances necessitate special requirements. Special designs will be required for all Multi-Family installations.

PERMITTING AND INSPECTION

In all cases, an electrical inspection by the Authorized Inspection Authority is required prior to notifying KU/ODP to install the meter and activate the service. KU/ODP must also approve the installation prior to connecting service to ensure the safety of KU/ODP employees who are working to complete your service request.

POINT OF ATTACHMENT

Customer cannot add a roof, structure, or enclosure that inhibits access to service connections by means of a ladder or bucket access (normal work methods).

SERVICE ENTRANCE LOCATION

KU/ODP's representative will designate the service entrance and meter location and work with customers to finalize all necessary service parameters. Unless expressly authorized by KU/ODP, no electrical work should start until KU/ODP has determined all of the service requirements. KU/ODP is not responsible for any delays, reconstruction work or additional cost incurred by customers or their contractors/builders if work is started before all of the necessary service parameters have been finalized.

GROUNDING

The NEC® requires one or more ground rods at the service entrance. Some Authorized Inspection Authorities require a minimum of two, so customers should consult with the Inspection Authority before construction begins. Ground rods need to meet the minimum requirements of the NEC® and

should be eight feet or longer. If multiple rods are installed, rods should be installed at least six feet apart. The grounding electrode shall be continuous from the service entrance main disconnect to one or both of the driven ground rod(s). All of the grounding bonds shall meet or exceed NEC® requirements.

MOTOR RESTRICTIONS

The most common types of motors found in a residence are those involved with HVAC systems. However, the following requirements apply to any type of motor. Single-phase motors may be served at 120 volts if the locked-rotor current at **rated voltage or any other loading requiring large starting currents in excess of 50 amperes**. The use of the motor does not otherwise interfere with service to others. Motors with locked-rotor current ratings in excess of 50 amperes must be served at 240 volts. Single-phase motors of new central residential cooling installations with total locked-rotor ratings of not to exceed 105 amperes (inclusive of any auxiliary motors arranged for simultaneous starting with the compressor) may be connected for across-the-line starting provided the available capacity of KU/ODP's electric distribution facilities at desired

point of supply is such that, in the judgment of KU/ODP, the starting of such motors will not result in excessive voltage dips and undue disturbance of lighting service and television reception of nearby electric customers. However, except with the express written consent of KU/ODP, **no new single-phase central residential cooling unit having a total lock- rotor rating in excess of 105 amperes inclusive of auxiliary motors arranged for simultaneous starting with the compressor** shall hereafter be connected to KU/ODP's lines or be eligible for electric service. Therefore, unless it is equipped with an approved type of current- limiting device for starting, which will reduce the initial and incremental starting current inrush to a maximum of 100 amperes per step. The KU/ODP tariff contains more information on motor

TEMPORARY & PERMANENT SERVICES

starting limitations.

General Information for Permanent Residential Service *(continued)*

AVAILABLE SERVICE

Two types of residential electrical services are available—**Overhead and Underground**. **Underground** service is generally available to everyone. Specific exceptions include areas subject to high water or flooding and in areas where excavation may be limited due to soil/rock conditions. If the new home is in an established underground residential subdivision, service must be provided underground. **Overhead** service is available if nearby utility facilities are overhead, except in areas specifically prohibited by local ordinance. The customer is responsible for any additional costs associated with underground service when overhead facilities are available even when ordinance or other restrictions limit providing service overhead. It is the customer’s responsibility to be aware of any applicable local codes and ordinances. Code requirements specify a minimum 100A service entrance for permanent residential services. All services must be wired for three-wire service. Two-wire service is no longer provided.

The only service voltage available for permanent Single-Family and Mobile Home residential applications is 120/240 volt single-phase, three-wire service up to 800A unless otherwise approved by KU/ODP. All single-phase services must be wired for three-wire service regardless of need. Two-wire service is no longer provided. For the largest homes that require services larger than 800 amp, the only option will usually be to provide 120/208 three-phase, four-wire service. Three-phase service cannot be established on the Residential Rate plan for Single-Family homes and must be served under the General Service rate. Customers should be aware that the cost to extend three-phase service to serve residential loads can be costly unless three-phase lines are nearby. Most Multi-Family facilities will also be served by 120/240 volt single-phase, three-wire service up to 800A except for high-rise Multi-Family Developments. These installations will generally be served with three-phase service.

This chart shows available electric service ratings for single-family residential structures and for satellite buildings. The size of service depends on the power requirements of the home and any associated equipment or facilities. LG&E does not determine the customer’s power requirements.

ELECTRIC SERVICE RATINGS FOR PERMANENT SINGLE-PHASE 120/240 VOLT SERVICES

SERVICE VOLTAGE	SERVICE AMPACITY	APPLICABLE STANDARD DRAWING	
120/240V 1-Phase Overhead or Underground	0 to 200 Amps	1 Conductor Max. Per Ø	81 20 0
	>200 to 400 Amps	2 Conductors Max. Per Ø	81 10 41
	>400 to 800 Amps unless otherwise approved by LG&E	2 Conductors Max. Per Ø	81 10 02
	>800 to 1200 Amps	5 Conductors Max. Per Ø	81 10 02

Transformer-rated metering will be necessary for single-phase services larger than 400 amps and additional requirements apply. Contact your Service Locator for information on the additional requirements.

TEMPORARY & PERMANENT SERVICES

Permanent Single-Family Residential Service

PERMANENT OVERHEAD RESIDENTIAL ELECTRIC SERVICES

CLEARANCE REQUIREMENTS

The National Electrical Safety Code (NESC®) and the National Electrical Code (NEC®) have established minimum overhead clearance requirements to ensure safe heights for different types of electrical conductors over various terrains depending on the type of usage expected. The diagram illustrates ground clearance requirements for a typical overhead permanent electric service. For additional information, refer to the latest NESC® and/or NEC® codes. Your electrical inspector and KU/ODP service representative will be able to assist you in a permanent service so adequate clearance is provided. Although KU/ODP provides the overhead service conductors, the customer must provide

adequate clearance at the facility to ensure all applicable clearance requirements can be met.

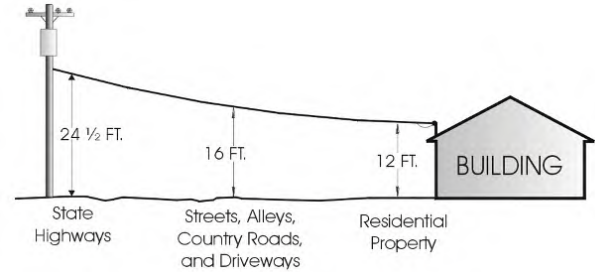

RESPONSIBILITY

The figure below identifies Utility and Customer responsibilities for a typical overhead electrical service.

Customer-owned and installed equipment

(All equipment installed to KU/ODP specifications)

- Weatherhead and mast /service attachment point
- Meter base, metering enclosures and disconnect
- Service entrance conductors
- Ground conductors, rods, etc.

KU/ODP-owned and installed equipment

- Utility service lines
- Connection to customer wiring
- Meter and metering transformer, if required

Notes: Instrument transformers, if required, will be provided by the utility, but installed by the customer. The utility will provide and install any associated meter wiring.

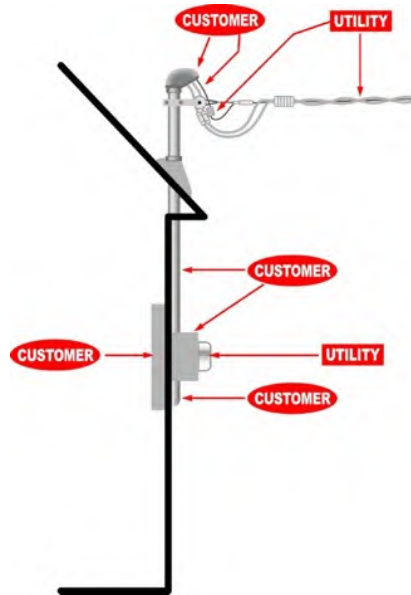

CONSTRUCTION STANDARDS

All residential overhead services are to be constructed in accordance with Standard Drawing # 81 20 02 found in Drawings section of this book.

TEMPORARY & PERMANENT SERVICES

Permanent Underground Residential Electric Services

RESPONSIBILITY

The illustration below shows a typical underground electrical service and identifies the shared responsibilities between KU/ODP and the customer.

Customer-owned and installed equipment

(All equipment installed to KU/ODP specifications)

- Meter base, meter enclosures and disconnect
- Ground conductors, rods, etc.

KU/ODP-owned and installed equipment

- Transformer and/or pedestal
- Utility service lines to the customer's point of ownership
- Meter and metering transformers, if applicable

Note: Instrument transformers, if required, will be provided by the utility, but installed by the customer. The utility will provide and install any associated meter wiring.

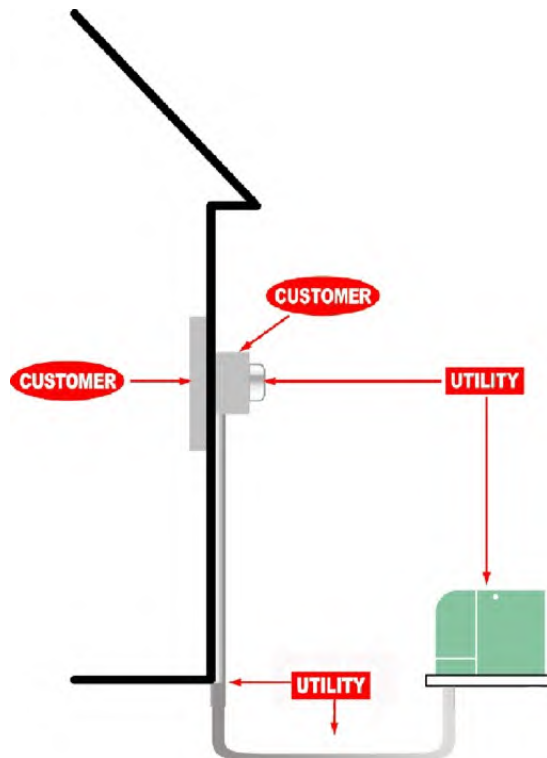

CONSTRUCTION STANDARDS

All permanent residential underground services in underground fed subdivisions are to be installed in accordance with KU/ODP Standard Drawing # 52 01 06 found in Drawings section of this book.

TEMPORARY & PERMANENT SERVICES

Mobile Home Services

DEFINITION

(NEC® Article 550) A mobile home is a factory-assembled structure transportable in one or more sections that is built on a permanent chassis and is designed to be used as a dwelling without a permanent foundation where connected to the required utilities and that includes the plumbing, heating, air conditioning and electrical system contained therein.

The information below applies to all mobile home services, even if the structure is subsequently placed on a permanent or semi-permanent foundation. Service to structures classified as Manufactured (or Modular) Housing, as defined in NEC® Article 550, which are mounted on a permanent foundation (i.e. not classified as a mobile home) can be constructed to the requirements for Permanent Residential Service, provided all of the requirements of NEC® Article 550 are met and the installation is approved by the Authorized Inspection Authority. See the requirements in “Permanent Residential Service”. In lieu of meeting the requirements for permanent residential service, service to manufactured housing will be treated in the same manner as a mobile home service.

Mobile home parks may be served either by the placement of individual services from the utility or by metering at a single site for the entire park or subgroups within the park by the owner. The instructions below are intended only for standard, permanently wired utility-provided service to mobile homes. Consult the Authorized Inspection Authority for special requirements for cord type service connections or any other special requirements.



The first step to arrange service for a mobile home is to make an application for service. See the section “Arranging for Service”. The customer must contact KU/ODP and complete an application for electric service. The form can be completed online lge-ku.com, or at KU/ODP offices or by phone at **1-800-981-0600**. All other steps in the section “Arranging for Electric Service” must also be followed.

KU/ODP recommends the use of a licensed electrical contractor to permanently connect service to any mobile home. In some jurisdictions in the KU/ODP service territory, the Authorized Inspection Authority requires the use of a licensed contractor if the mobile home customer is not the property owner. Regardless of who performs the work, an electrical permit must be obtained from the Authorized Inspection Authority. Once all work has been completed and the service has passed inspection by the Authorized Inspection Authority, KU/ODP will energize the service following notification that the service is ready and provided all other requirements for service have been met.

LINE EXTENSIONS

In accordance with 807 KAR 5041 Section 12, KU/ODP will extend a single-phase overhead electric line up to 1000 feet at no cost to the customer provided the mobile home is placed on a permanent foundation. The customer will be charged for the full cost of any extension beyond 1000 feet. If the mobile home is not placed on a permanent foundation, then lines will be extended

only 150 feet without charge. A fixed customer advance charge will be involved for all extensions between 151 feet and 300 feet. The full cost of extensions beyond 300 feet will be paid by the customer, except that all customer advance fees between 151 feet and 1000 feet will be subject to refund provided continuous service is provided to the site for a minimum period of four years.

SERVICE EQUIPMENT

Mobile Home service equipment will be provided to the requirements of the NEC® and approved for use by the Authorized Inspection Authority. The following requirements apply:

TYPE OF SERVICE

Two types of residential electrical service are available, Overhead and Underground. Underground service is generally available to everyone. Specific exceptions include areas subject to high water or flooding and in areas where excavation may be limited due to

soil/rock conditions. Overhead service is available if nearby utility facilities are overhead, except in areas specifically prohibited by local ordinance. The customer is responsible for any additional costs associated with underground service when overhead facilities are available even when ordinance or other restrictions limit providing service overhead. It is the customer’s responsibility to be aware of any applicable local codes and ordinances.

TEMPORARY & PERMANENT SERVICES

Mobile Home Services *(continued)*

GENERAL REQUIREMENTS

Service equipment for mobile homes shall be located adjacent to the mobile home and not mounted in or on the mobile home. This equipment shall be accessible and shall be located in sight from and not more than 30 feet from the exterior wall of the mobile home it serves.

KU/ODP will provide all utility facilities up to the Point Of Delivery. The Point Of Delivery for overhead services is defined as the customer-owned (KU/ODP approved) terminating structure and service entrance. The customer's facilities must be installed in accordance with all national, state, local, utility codes, standards and/or regulations.

SERVICE DISCONNECT

The customer must provide a weatherproof disconnect switch, over-current protection, grounding provisions and all other associated facilities necessary to provide service to the requirements of the NEC®. The disconnect must be located on the load side of the meter.

OVERHEAD SERVICES

The customer must provide a suitable pole or structure of adequate size and strength for terminating the overhead electric service drop provided by the utility. The customer must also provide the service weatherhead and all other associated service entrance equipment. Customer-provided poles must have sufficient height to provide all required clearance for the company's service drop and any telephone, cable TV or other attachments. Poles must not be less than 5 inches in diameter at the top if round and shall be set at depths appropriate for the pole's length.

Wooden poles must be pressure or thermally treated with a KU/ODP-approved preservative. Metering and service equipment can be located on the customer's termination structure. All termination structures must be approved for use by KU/ODP.

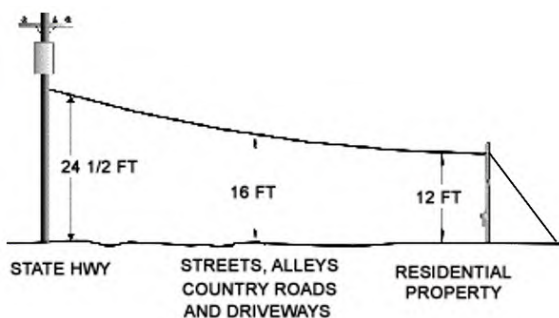

TEMPORARY & PERMANENT SERVICES

Mobile Home Services *(continued)*

CLEARANCE REQUIREMENTS

The National Electrical Safety Code (NESC®) and the National Electrical Code (NEC®) have established minimum overhead clearance requirements to ensure safe heights for different types of electrical conductors over various terrains depending on the type of usage expected. The diagram illustrates ground clearance requirements for a typical overhead permanent electric service. For additional information, refer to the latest NESC® and/or

NEC® codes. Your electrical inspector and KU/ODP service representative will be able to assist you in a permanent service so adequate clearance is provided. Although KU/ODP provides the overhead service conductors, the customer must provide adequate clearance at the structure to ensure all applicable clearance requirements can be met.

RESPONSIBILITY

Customer-owned and installed equipment

(All equipment installed to KU/ODP specifications)

- Service pole and cable attachment provisions
- Meter base, meter enclosures and service disconnect
- Service entrance conductors (weatherhead and beyond)
- Ground conductors, rods, etc.

Notes: Service neutral and meter base must be permanently grounded in accordance with NEC® guidelines.

KU/ODP-owned and installed equipment

- Utility service lines (to weatherhead on customer's structure)
- Connection to customer wiring
- Electric meter and metering transformers, if applicable

UNDERGROUND SERVICES

The customer must provide a suitable post, pedestal or other structure for mounting metering and associated service equipment. The minimum acceptable post size is six-inches by six-inches by eight feet long. This size may need to be increased to provide adequate surface area to mount the meter base, disconnect switch and other service equipment. Wooden poles and posts must be pressure or thermally treated with a KU/ODP-approved preservative. All service structures must be approved for use by the utility.

Post installation must include all necessary bracing to prevent the meter base from swaying. Since stability is a concern with prefabricated pedestals, they are not recommended. You must obtain KU/ODP approval before installing such pedestals. Metal posts, frames or pedestals can be used as an option to wooden poles or posts if approved by KU/ODP. These options do not diminish or eliminate the requirements for height above the grade for meter mounting. See drawing # 81 20 07 for post depth, height and other details (in Drawings section of this handbook).

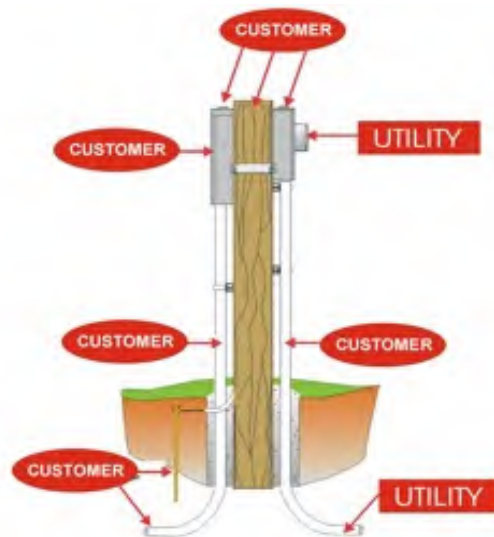

TEMPORARY & PERMANENT SERVICES

Mobile Home Services *(continued)*

RESPONSIBILITY

Customer-owned and installed equipment

(All equipment installed to KU/ODP specifications)

- Service support (post or pedestal) and bracing
- Meter base and disconnect
- Service entrance conductors
- Ground conductors, rods, etc.

Notes: Service neutral and meter base must be permanently grounded in accordance with NEC® guidelines.

KU/ODP-owned and installed equipment

- Transformer or splice box
- Utility service cable to customer's point of ownership
- Connection to customer wiring
- Electric meter and metering transformers, if required

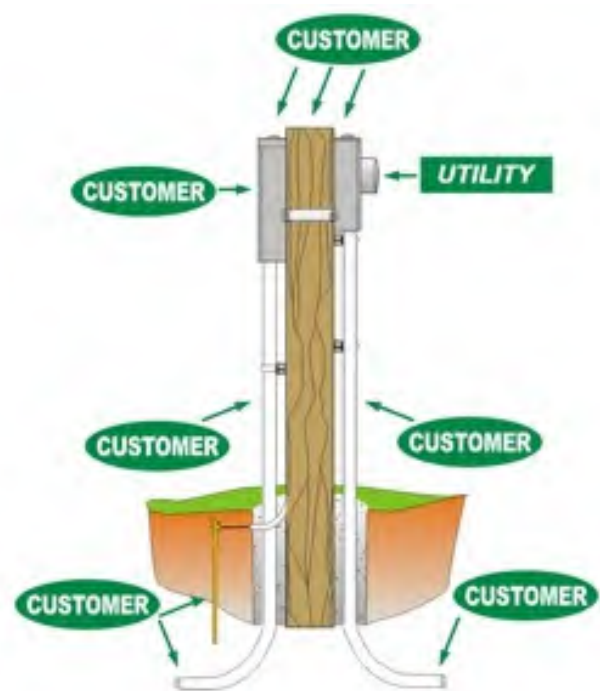

Please be aware of KU/ODP's requirements for a clear work zone area around utility equipment for service structures. Service structures should be located out of the reserved work zone area.

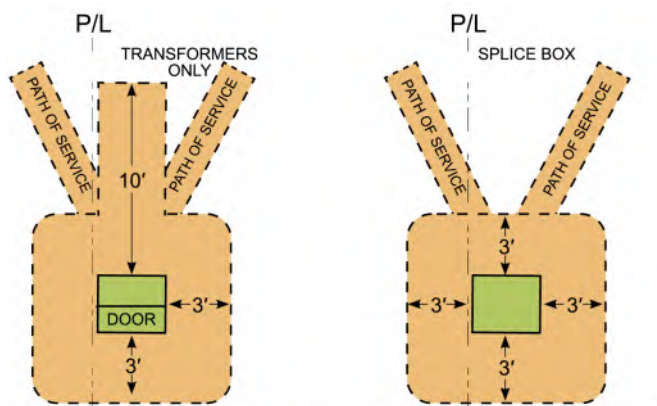

ROAD R/W OR REAR PROPERTY LINE

Equipment Clear Working Zone

TEMPORARY & PERMANENT SERVICES

Multi-Family Structures

Multi-Family dwellings served under the residential rate must meet all of the provisions found in the section on permanent residential services. Some additional provisions apply as described below. The following definitions and classifications apply to multi-family services and developments.

SPECIAL DEFINITIONS/CLASSIFICATIONS

Dwelling unit—a structure that is used as a home, residence or sleeping place by one or more persons maintaining a common household.

Multi dwelling unit—a structure with more than one dwelling unit and not more than three stories above grade.

High-rise building—any multi-family building with four or more stories.



Low Density Multi-Family installations— a single multi-family building of any size, or two or more multi-family buildings containing **less** than five (5) dwellings per building.

High Density Multi-Family installations—developments with two (2) or more buildings containing **not less** than five (5) family units per building.

LINE EXTENSIONS

The cost to provide service to multi-family buildings is dependent on many factors, including how far KU/ODP must extend lines to serve the building(s) and whether service is to be provided overhead or underground. Other factors include the number of buildings involved, the number of dwelling units per building, the number of floors in each building and the average density of dwelling units per acre. Single multi-family buildings and others meeting the definition of “Low Density” facilities will be treated

in the same manner as service provided to individual residences. Two or more buildings meeting the definition of “High Density” multi-family facilities may be subject to a reduction in the cost to provide service provided there is an average density of eight dwellings per acre. Service to high-rise buildings is complex and unique and must be addressed individually. A KU/ODP service representative will work closely with customers to identify all costs to provide service to multi-family installations.

SPECIAL METERING REQUIREMENTS

In all cases of multi family structures, individual meters shall be clearly and permanently identified to determine which dwelling unit service is supplied. Details on meter labeling requirements for multi-family structures can be found in section “Meter Information”. Should changes occur in wiring, location, etc., KU/ODP must be contacted and the change noted on the meter installation.

Individual meters are required for each newly constructed dwelling unit in a multi dwelling building except as excluded below:

Exclusions:

1. Transient multi dwelling units, such as hotels, motels, campgrounds, hospitals, nursing homes, convalescent homes, college dormitories, fraternities, sororities, boat docks and mobile homes without a permanent foundation and not connected to sanitation facilities.

2. Electricity used in central HVAC systems.
3. Electricity used in high-rise buildings.
4. Applicants who desire master metering on buildings for which master metering is prohibited may make a formal complaint to the Commission. Applicant must prove the cost of individual metering is greater than the long-term benefits of individual metering to the consumers of the electricity at the building.

Residential rates are based on service to individual family dwelling units and are not applicable to multi family dwellings combined on a single meter. For each family unit to be billed under the applicable residential rate, each dwelling unit must have the electrical service metered separately. Any other metering configuration will result in billing under an appropriate commercial rate.



COMMERCIAL
& INDUSTRIAL
SERVICES

COMMERCIAL & INDUSTRIAL SERVICES

Introduction

The first step toward arranging for permanent Commercial or Industrial service is to follow the guidelines in the section entitled “Arranging for Electric Service”. The customer must contact KU/ODP and complete an application for electric service. The form can be completed online at lge-ku.com, at KU/ODP offices or by phone at **1-800-383-5582** or **859-367-1200**. All other steps in the section “Arranging for Electric Service” must also be followed.

Some general information on arranging for permanent service can be found below.

While no typical configuration for Commercial or Industrial services can be devised, some general information on arranging for permanent service can be found below. However, drawings in Drawings section of this handbook outline basic service requirements.

Type Of Service

Two types of service are available, Overhead and Underground. Underground service is generally available to everyone. Specific exceptions include areas subject to high water or flooding and in areas where excavation may be limited due to soil/rock conditions. Overhead service is available if nearby utility facilities are overhead, except in areas specifically prohibited by local ordinance.

The customer is responsible for any additional costs associated with underground service when overhead facilities are available even when ordinance or other restrictions limit providing service overhead. It is the customer’s responsibility to be aware of any applicable local codes and ordinances.

Service Voltages

Service is normally provided at secondary voltage levels. However, under certain conditions, service can be provided at primary distribution or transmission voltages. In these cases, the customer

must construct and maintain all high voltage lines and equipment and provide all voltage transformation equipment. The following nominal voltages are available:

SINGLE-PHASE SECONDARY SERVICE VOLTAGES	APPLICATION
120/240 volt 3-wire	Lighting and small commercial services where 120/208 volt 4 wire is nearest source
120/208 volt 3-wire Network	
THREE-PHASE SERVICE VOLTAGES	APPLICATION
Secondary	
120/208 volt 4-wire grounded wye	Service from either overhead or underground
277/480 volt 4-wire grounded wye	Service from overhead and underground
120/240 volt 4-wire grounded delta	Service from overhead and underground
Primary	
2,400/4,160 volt 4-wire grounded wye	Restricted Service Area
7,200/12,470 volt 4-wire grounded wye	Restricted Service Area
13,200/22,900 volt 4-wire grounded wye	Restricted Service Area (ODP only)
19,900/34,500 volt 4-wire grounded wye	Restricted Service Area
Transmission	
69,000 volt 4-wire grounded wye	Restricted Service Area
138,000 volt 4-wire grounded wye	Restricted Service Area
161,000 volt 4-wire grounded wye	Restricted Service Area

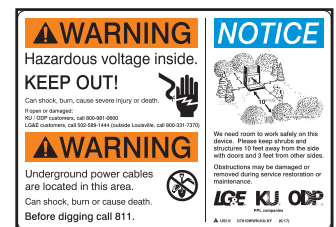

Special requirements apply for services greater than 480 Volts

COMMERCIAL & INDUSTRIAL SERVICES

Installation Costs

The installation costs for commercial or industrial, overhead or underground electric service depends on the size, type and location of KU/ODP's existing facilities and the type of service desired. These costs will vary according to KU/ODP ability to

access existing utility facilities and/or the need to construct new facilities. Contact your KU/ODP representative and/or account representative to discuss the specifics of your project.

Number/Type of Services

KU/ODP will provide each customer with a single-service voltage/configuration and will provide this service to a single location at the facility. Customers provided with three-phase service are

expected to provide any necessary voltage transformation needed for lighting and outlet loads.

Grounding

The NEC® requires one or more ground rods at the service entrance. Some Authorized Inspection Authorities require a minimum of two, so customers should consult with the Inspection Authority before construction begins. Ground rods need to meet the minimum requirements of the NEC® and should be eight feet

or longer. If multiple rods are installed, rods should be installed at least six feet apart. The grounding electrode shall be continuous from the service entrance main disconnect to one or both of the driven ground rod(s). All of the grounding bonds shall meet or exceed NEC® requirements.

Overhead Services (600 Volts or Less)

OVERHEAD CLEARANCE

The National Electrical Safety Code (NESC®) and the National Electric Code (NEC®) have established minimum overhead clearance requirements for electrical conductors that span over various types of terrain. The customer must ensure the attachment point on the structure at the service mast or service pole, as

applies, will allow KU/ODP to install the utility service lines and maintain the required clearances. For additional information on clearance requirements, refer to the latest edition of the NESC®, NEC® or the Authorized Inspection Authority that has jurisdiction.

OVERHEAD INSTALLATION

Customer-owned and installed equipment

(All equipment installed to KU/ODP specifications)

- Service attachment point, mast or service pole(s)
- Braces or guys
- Meter base and other required metering enclosures, supports and equipment
- Service entrance conductors and conduit
- Service disconnect and other required service entrance equipment
- Ground conductors, rods, etc.
- Lightning arrester (required for 480v delta secondary service. To be installed at service entrance point)

KU/ODP-owned and installed equipment

- Utility service cables to the point of delivery
- Connections to customer wiring
- Electric meters and metering transformers (if required)

Note: Instrument transformers, if required, will be provided by the utility, but installed by the customer. The utility will provide and install any associated meter wiring.

COMMERCIAL & INDUSTRIAL SERVICES

Overhead Services (600 Volts or Less) *(continued)*

The Point of Delivery for overhead service is considered to be the transition from KU/ODP utility service lines to the customer's service entrance conductors. The transition typically occurs at the customer's weatherhead located on the service mast or service pole. If metering must be installed at a location remote from the point of demarcation, special arrangements must first be made with KU/ODP.

The customer's service entrance conductors must not be spliced.

Permanent electric services for commercial or industrial overhead installations are to be constructed in accordance with KU/ODP Standards and applicable codes, standards and regulations. Service entrance conductors must be marked with color-coded tape per NEC® specifications. Contact your KU/ODP representative to discuss project details or to address any special requirements for the project.

Permanent Underground Service (600 Volts or Less)

CUSTOMER-PROVIDED FACILITIES FOR UNDERGROUND SERVICE

It may be necessary for KU/ODP to extend primary lines onto the customer's property when it is not practical to provide service from the property boundary. The length and nature of an underground service lateral will be governed by good engineering practices and shall be installed in such a manner that it is free of drainage fields, septic systems, pipes, areas of deep cultivation and other interference. The customer is responsible for providing all associated trenches, conduit systems, equipment pads, manholes, etc. located on the customer's property that are required for the purpose of providing service. The customer also must provide the secondary service cable. (See note 1.) KU/ODP will install all service-related metering equipment and cable, except service cables, once these facilities have been installed and approved.

All customer-provided facilities must be installed to KU/ODP standards and be inspected and approved for use by KU/ODP

before service can be provided. KU/ODP requires twenty-four (24) hours notice to schedule an inspection of customer-provided facilities. The customer will own and maintain all customer-provided facilities, but KU/ODP will maintain exclusive control over their access and use. No access will be granted to any customer-provided facilities used to provide service. No other facilities or other utilities will be placed in customer-provided cable systems under the exclusive control of the utility without the express approval of KU/ODP. Under some conditions, KU/ODP will allow a single trench to be shared by other utilities, such as CATV and telephone provided other utility lines do not enter manholes, splice boxes or enclosures or are placed under KU/ODP equipment pads. No customer cables, equipment or other facilities will be allowed to share the service trench. See your KU/ODP representative for additional information.

COMMERCIAL & INDUSTRIAL SERVICES

Permanent Underground Service (600 Volts or Less) *(continued)*

UNDERGROUND INSTALLATION

Customer-owned and installed equipment

(All equipment installed to KU/ODP specifications)

- Customer-owned cable systems (service entrance conductors)
- Cable systems provided by the customer for ku/odp use (conduit, manholes, pads, enclosures, etc.)
- Meter base and other required metering enclosures, supports and equipment
- Service disconnect and other service entrance equipment
- Ground conductors, rods, etc.

KU/ODP-owned and installed equipment

- All service equipment including pad-mount transformer, switchgear, pedestal, etc.
- Utility primary and secondary cables
- Connections to customer wiring
- Electric meter and instrument transformers (if required)

Note 1: KU/ODP will provide service cable to a group of two or more meters.

Note 2: KU/ODP requires commercial customers to install secondary cables and provide connectors to pad-mount paddles. Instrument transformers, if required, will be provided by the utility but installed by the customer. The utility will provide and install any associated meter wiring.

The Point Of Delivery for underground service at secondary distribution voltages is considered to be at the secondary lugs of KU/ODP pad-mount transformers when the transformer is on private property or at a secondary enclosure at the customer's property line if the transformer is in a public right-of-way.



LOCATION OF EQUIPMENT

The customer must provide a location suitable for the installation of the pad-mount transformer, switchgear and other associated service supply equipment. The area must be free from obstructions, provide adequate access, work and safety clearances.

Utility equipment will not be located inside of buildings or in below-ground vaults unless no other options exist to provide service. For more complete information on equipment location requirements, see Part 1 of this handbook titled "Requirements for Electric Service Equipment".

SPECIAL REQUIREMENTS—TRANSFORMERS AND OTHER OIL-FILLED EQUIPMENT LOCATED OUTSIDE BUT NEAR BUILDINGS

KU/ODP restricts the location of transformers and other oil-filled equipment near buildings to the following:

- 1Ø Transformers 75 kVA or less shall be located at least 5 feet from building walls.
- 1Ø Transformers 100 kVA to 250 kVA shall be located at least 10 feet from building walls.
- 3Ø Transformers 75 kVA to 500 kVA shall be located at least 15 feet from building walls.
- 3Ø Transformers 750 kVA to 3000 kVA shall be located at least 25 feet from building walls.

Placement of transformers and other oil-filled equipment closer to buildings will require a fire containment enclosure and/or modifications to the building to reduce the potential fire risk. Fire containment requirements for oil-filled equipment can be found on Drawing # 42 06 20 in Drawings section of this handbook.

Note: The fire containment requirements do not meet the environmental requirements for oil containment when required.

In addition to oil-filled equipment limits near buildings, other requirements for equipment location will apply for special installations near pools, fire hydrants, sprinkler valves, standpipes, fire escapes and building access openings and any facilities used to dispense or store hazardous liquids or gases.

Contact your KU/ODP representative for requirements and possible exceptions to these rules and/or contact the State Fire Marshall, Department of Housing, Buildings and Construction, Division of Fire Prevention at 502-564-3626.



SPECIAL PROCEDURES



SPECIAL PROCEDURES

Overhead to Underground Service Conversions

CONVERSION COSTS

When an existing overhead service of adequate capacity and maximum 200A size is replaced with underground at applicant's request, a removal cost, in addition to the appropriate service installation fee should be paid when the replacement service is requested.

If a customer is adding load to a home or business, and the additional load will require KU/ODP to change out the existing overhead service, the customer will have the option of either staying with an overhead service or going to an underground service with applicable customer contribution required.

RESPONSIBILITIES

The figure to the right identifies the shared responsibilities between KU/ODP and the customer for a typical conversion of overhead to underground electrical service.

Customer-owned and installed equipment

(All equipment installed to KU/ODP specifications)

- Meter base, metering enclosures and disconnect (up to code)
- Ground conductors, rods, etc.

KU/ODP-owned and installed equipment

- Utility secondary lines to the customer's point of ownership
- Connections to customer wiring
- Electric meter and metering transformers, if required

Notes: Instrument transformers, if required, will be provided by the utility but installed by the customer. The utility will provide and install any associated contact meter wiring.

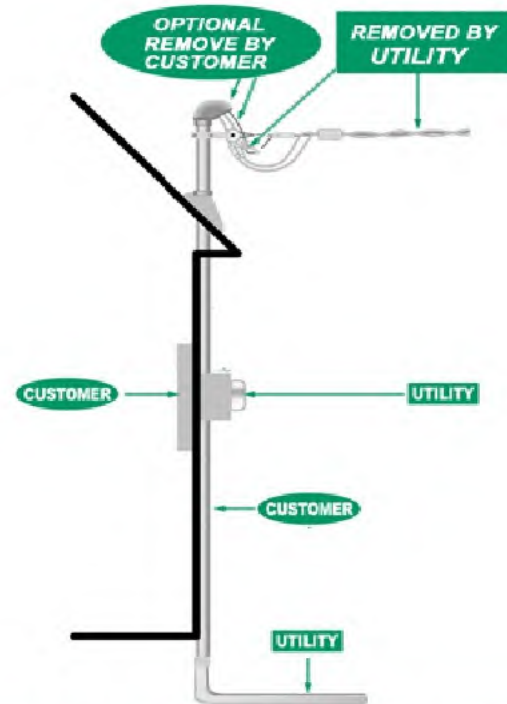

TYPICAL SERVICE CONVERSION

CONSTRUCTION STANDARDS

All residential overhead to underground service conversions will be constructed to KU/ODP Standards.

SPECIAL PROCEDURES

Rewire Procedure

If an existing electrical service is to be rewired, certain standards and specifications must be followed. If you are going to have the work done, it is recommended that a qualified licensed electrical

contractor be used. All work must be completed to the requirements of the NEC® the NESC® and the Authorized Inspection Authority.

- Regardless of whether a licensed electrician or the owner performs the work, an electrical permit must be obtained and electrical work must pass all required electrical inspections before KU/ODP can make any changes to or reconnect the service.
- Before proceeding with any rewiring work, the responsible party must contact the appropriate KU/ODP representative for a meter location. To determine the appropriate representative, contact Customer Service at 1-800-981-0600 for residential rewiring or commercial/industrial work.
- The NEC® requires all new and upgrade residential services to be rated a minimum of 100 amp. KU/ODP requires all residential services to be 120/240 volt, single-phase 3-wire.
- Besides issuing a meter location, the KU/ODP representative will also advise the customer about such things as the acceptable meter base height, location, etc. if necessary. Construction standard drawings are provided in this handbook detailing the most common service requirements. Clearance of three feet is required in front of any meter and the customer must own that area. The area two feet on either side of the meter location must be clear of any obstructions. A minimum of three feet of clearance is required between the electric meter base and a gas meter (outside to outside).
- An overhead electric service line cannot pass in front of a window unless there is a minimum horizontal clearance of 36 inches. Electric service cannot pass over a chimney or roof vent.
- An overhead service pole will typically be required for 200 amp services (and below) if the service length exceeds 100 feet and when adequate clearance cannot be obtained for services less than 100 feet. The maximum length with a service pole will be 150 feet provided voltage drop and flicker requirements can be met.
- A service pole will also typically be required for overhead service runs over 70 feet for services larger than 200 amps. The maximum distance with a service pole for this size service will not exceed 100 feet provided voltage drop and flicker requirements can be met.
- After the service has been inspected, the Inspection Authority will notify KU/ODP and, in most cases, the service will be connected WITHIN five working days.
- On the day the service is scheduled to be connected, KU/ODP personnel must be able to enter the home or business. They must see the approval (green sticker) of the Authorized Inspection Authority and have access to the main breaker. Approval sticker not used at ODP.



SUPPLEMENTAL INFORMATION



SUPPLEMENTAL INFORMATION

Reading Your Own Meter

Your electric meter is like an odometer on a car. Instead of measuring miles, it measures energy in kilowatt-hours of use. **One kilowatt-hour** is equal to the amount of energy needed to supply 1000 watts (10 - 100 watt light bulbs) of load for one hour.

The meter keeps count of the total amount of electricity used to operate all of your electrical appliances. The electric meter face usually has four or five dials. Each dial has 10 numbers and a

pointer. The pointer turns when electricity is being used; it moves so slowly that you can barely see it turn.

The dials are read from left to right. When the pointer is between numbers, record the number that the pointer has passed. This will always be the smaller number. As shown in the figure below, each dial rotates opposite of the one before it, so some practice may be required to read the meter correctly.

The examples below show how to read a meter correctly.

Example #1:

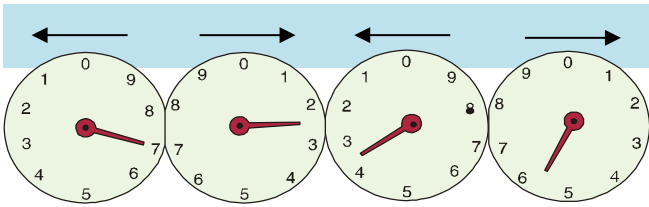

The correct reading for this meter is: **7,235.**

Example #2:

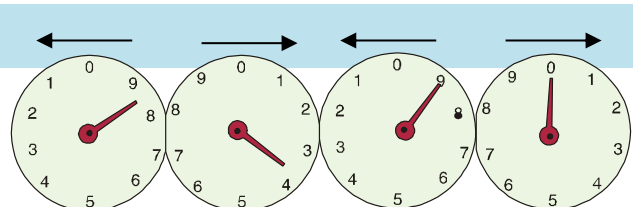

The correct reading for this meter is: **8,390.**

To check one day's energy use, make two readings 24 hours apart and subtract the first reading from the second. You can add daily results for monthly amounts or read the meter at the beginning of the month and then subtract that reading from a reading taken at the end of the month. If you read your meter on the same days as KU/ODP, you can check the monthly usage that will be charged on your bill. In addition to cost information, your bill will always show total usage in kilowatt-hours.

Small differences in usage should be expected if you do not read the meter at exactly the same time KU/ODP reads the meter each month. However, it should be possible to identify a large discrepancy in usage.

If you feel the amounts that are displayed incorrect, contact KU/ODP Customer Service at 1-800-981-0600.

For example:



$$\begin{array}{r}
 40967 \\
 - 40772 \\
 \hline
 = 195 \text{ kwh used}
 \end{array}$$

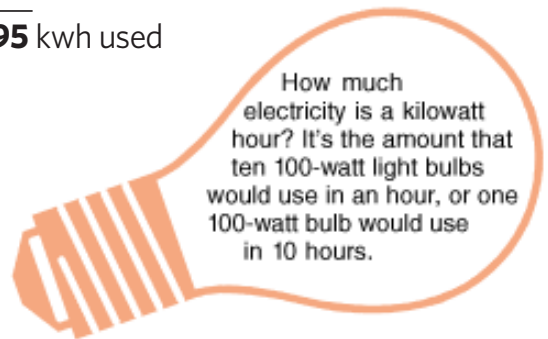

SUPPLEMENTAL INFORMATION

Emergency Power Sources

REQUIREMENTS FOR EMERGENCY AND STANDBY GENERATORS

All permanently installed generators and other types of standby power sources and their associated interface wiring are to be installed in accordance with the NEC®. Such installations are subject to inspection and approval by KU/ODP and are subject to removal from the premise wiring if not operated and maintained in a safe manner. The customer must notify KU/ODP whenever a permanently installed standby system has been installed.

Permanently installed standby power systems are to be connected to the customer's wiring system by a permanently installed transfer switch intended for that purpose. Transfer switches can either be manually operated or automatically controlled. Wiring work and installation of the transfer mechanism associated with the standby power source shall be performed by a licensed electrical contractor. The transfer switch or switching system shall

disconnect all ungrounded service conductors connected to the KU/ODP system prior to connecting the standby power system to the conductor's supplying load. Additionally, the transfer switch is to be designed and installed so that connecting the standby system to the KU/ODP system is prevented for any mode of operation.

When in the position which disconnects the KU/ODP supply, the transfer switch must have a visible opening and must be lockable in the disconnected position. The transfer switching schemes must meet applicable building and electrical codes.

Portable generators shall likewise not be interconnected to the KU/ODP supply except when the interface is made through a permanently installed transfer switch.

PORTABLE GENERATOR SAFETY

When power is out for any reason, portable generators can be used to temporarily supply electricity. But if used improperly, portable generators can be dangerous to the customer and to KU/ODP personnel working to restore service. Here are some tips for safe operation:

- Portable generators are designed to supply power directly to one or more appliances. Never "rig" a portable generator into your home wiring system. The voltage can back feed into the KU/ODP system and be transformed to very high levels. This can overload and damage the generator. It can also seriously injure KU/ODP personnel working to restore service on what is expected to be a de-energized line. When power is restored, an electrical fault can occur because the generator's voltage will not be in phase with the KU/ODP system voltage. This can seriously damage the premise's electrical system and/or the generator.
- Only operate portable generators in ventilated areas. Portable generators produce carbon monoxide fumes that are potentially lethal in enclosed areas.
- Use heavy-duty extension cords with your appliances and your portable generator, and don't overload an extension cord with too many appliances.
- Portable generators aren't intended to run your entire home electrical system. Know which equipment you'll need in an emergency situation, and only plug those items into your generator. Do not overload the generator and make sure the protective devices on the generator work correctly.

Permanent generators, as stated above, require a device called a transfer switch that prevents them from being connected to the KU/ODP electric system. If you plan to permanently install a portable generator, be sure to have your electrical contractor install the proper transfer switch.

For additional information, use the link below to the Consumer Product Safety Commission web page on generator safety: cpsc.gov



SUPPLEMENTAL INFORMATION

Landscaping And Vegetation Near Electrical Lines

CLEARANCE TO OVERHEAD LINES

Because trees and other vegetation touching power lines are the most frequent cause of power outages, care must be taken not to plant anything near overhead electrical lines that will grow tall enough to reach the line. When planting trees near power lines, work with an arborist or the nursery where you purchase your trees to choose a tree type that will have a growth pattern suitable

for the distance to where it is planted (from overhead lines). Doing so helps minimize power outages and unsightly trimming that may become necessary to provide clearance for power lines as the tree grows. For this discussion, trees are categorized as large, medium and small.

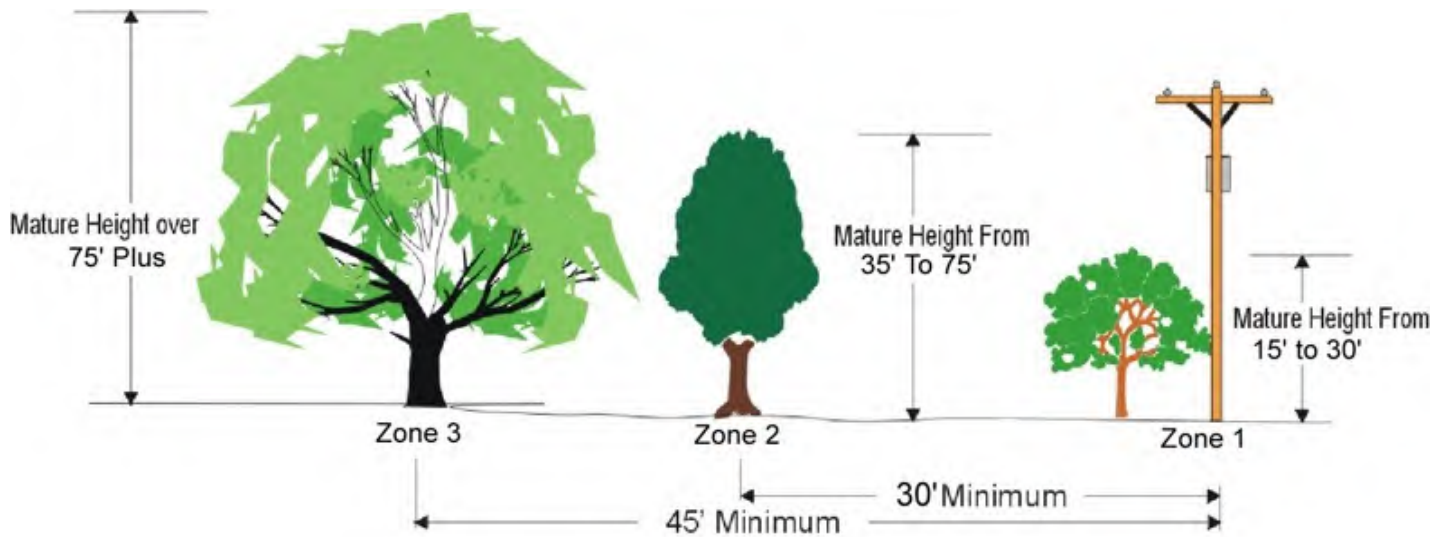

The tree's mature height should be less than 30 feet if it is to be planted within 15 feet of an overhead electric line.

ZONE 1 TREES

When planting less than 15 feet from overhead power lines, choose small-growing trees and bushes that are adaptable to this area and grow no taller than 15 to 30 feet. These trees and bushes will require a minimal amount of pruning as they grow.

ZONE 2 TREES

When planting at least 30 feet from power lines, slightly larger trees may be appropriate. Work with your local nurseries to choose a medium-sized tree that will mature to a height no taller than 75 feet.

ZONE 3 TREES

Visualize the tree at its full size, height and width. Large trees, such as oaks, often spread out considerably as they grow. With proper planning, you can have a variety of beautiful trees of varying sizes in and around power lines without having to worry about them causing problems in the future. Plant the saplings of large-growing species at least 45 feet from power lines in order to avoid pruning problems in the future.

SUPPLEMENTAL INFORMATION

Landscaping And Vegetation Near Electrical Lines *(continued)*

TREE SAFETY

Choosing the correct tree to plant near overhead lines will provide for a safe and attractive installation that will not require unsightly trimming. However, many older trees are located too close to overhead lines. KU/ODP trims trees only to the extent necessary to provide clearance for the overhead lines.

KU/ODP strongly recommends the use of professional tree trimmers certified for electric line clearance work when trimming or removing trees that are near power lines. Other professional trimmers can be used provided no part of the tree is within 10 feet of the line. Trimming and removal work can be extremely dangerous. Tree limbs, ropes and most ladders are conductors of electricity. If these or any other objects come into contact with a power line, anyone working on or near the tree will be at risk. The customer is also responsible for any damage done to power system lines and equipment caused by the work.



Because tree limbs can conduct electricity, never let children climb or play in trees near power lines. Because trees are fairly good conductors of electricity, children do not have to actually touch the line to be shocked. If a limb sags down and comes into contact with a power line,

the whole tree can become energized and can even injure someone standing on the ground nearby. Help avoid serious injury and never let children climb or play in trees near overhead power lines.

CLEARANCE TO UNDERGROUND LINES

Even when electric lines are placed underground, you must be careful when planting trees, gardens and doing other types of landscaping work. Few customers know the exact location or depth of underground utility lines or the service lines (power, gas, telephone, CATV, etc.) coming to their house. Whenever underground utilities are nearby, you have to be careful to dig safely.

Although most electrical lines should be placed below the level needed for gardens and smaller plantings, other utilities may not be as deep. Digging for trees and other larger plantings can easily reach the expected depth of underground electric lines. Additionally, ground settling, soil erosion and grade changes often reduce the depth of underground lines.



Building a deck, fence, home addition or putting in a pool? Planting some trees or shrubs to enhance the beauty of your home? At least two business days before performing excavation work anywhere in Kentucky, please call 811 (Dial 8-1-1) to request location of underground facilities. If you live outside of Anderson, Bourbon, Clark, Fayette, Franklin, Harrison, Jessamine, Madison, Montgomery, Scott, and Woodford counties, you must also call KU at **(800) 981-0600** at least two business days before performing any excavation to request a location of KU's underground electric facilities. Visit our website at lge-ku.com and input your county name to see if you can make one call to Kentucky 811 or if you need to contact both 811 and KU. KU requests this to protect excavators and the public and preserve the reliability of underground facilities. Excavators are required to make contact with KU and other operators of underground facilities under Kentucky law.



Call 811 before Digging anywhere in Kentucky and allow 48 hours before beginning excavation. Outside the Lexington area you will also need to call KU 1-800-981-0600 for location of electric underground lines.

SUPPLEMENTAL INFORMATION

Landscaping And Vegetation Near Electrical Lines *(continued)*



In Virginia, call 811 (Miss Utility) and allow 48 hours before beginning excavation.

PLANTING NEAR ELECTRICAL EQUIPMENT

Customers often place landscape plantings around utility equipment so it cannot be seen. However, KU and ODP have specific clear space requirements for such plantings, even small plants, near its pad-mounted electrical equipment. Planting too close to equipment delay service restoration and can present a safety hazard to both electrical workers and customers. KU/ODP employees and contractors are authorized to trim or remove any plantings that interfere with safely working around electrical equipment. If the offending plantings are found during routine inspections, KU/ODP will notify the customer and the customer shall remove the plantings. In either case, KU/ODP will not be responsible for any losses or damages resulting from trimming or removal of plantings that interfere with safe access to utility equipment.



To summarize:

- Don't plant anything directly under power lines.
- Plant only low-growing shrubs or hedges within 10 feet of electric lines.
- Trees that grow to heights of up to 75 feet should be planted at least 45 feet away from electric lines.
- Where electric service is underground, don't plant anything within 10 feet of the pad-mounted transformers. Remember; find out where all underground utilities are located before digging.
- Don't plant trees in the right-of-way of high capacity transmission lines.

Minimum Clearance for Padmount Transformer

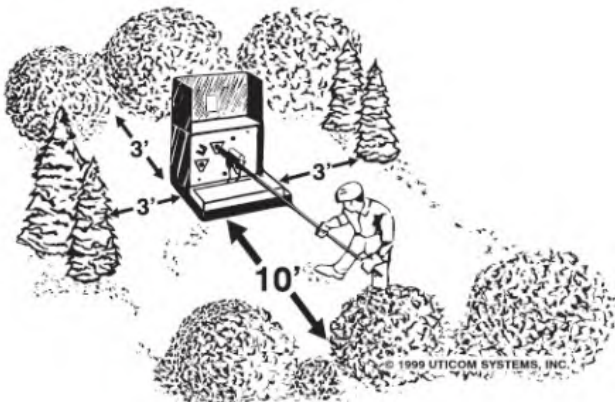

“Where there is ground-mounted electrical equipment, there are underground electrical lines nearby.”



SERVICE RELATED
DRAWINGS

DESCRIPTION OF DRAWINGS

Drawing #	Description
Load Data Sheet	Electrical Load Data Submittal Sheet
02 10 20	NESC Clearances of Wires, Conductors and Cables Passing Over or Near Swimming Pools
04 10 04	Pole, Guy and Pad Protection
12 02 10	Recommended Mobile Home Individual Underground Service
12 02 12	Farm Multi-Service and Individual Mobile Home Meter Installation
12 10 02	Requirements for Overhead 120/240V Temporary Service
40 02 04	Concrete Encased Duct Layouts and Trench Dimensions not including Street Lights
42 05 06	Single Phase Transformer Pads
42 06 03	3 Phase Transformer Pads
42 06 04	Standard Pad Installation for 3Ø Transformers 75kVA to 3000kVA
42 06 20	Padmount Transformer Separation from Buildings and Fire Protection
42 06 22	Typical Concrete Pad Installation for 4 Compartment Deadfront Switchgear
42 06 24	Deadfront Switchgear Box Pads
51 06 06	Underground Parallel Secondary Installation
52 01 00	Single Phase Underground Residential Service
52 10 02	Requirements for Underground 120/240V Temporary Service
81 10 00	Minimum Specifications for C.T. Enclosure Cabinet
81 10 02	Minimum C.T. Enclosure Size Using Up to 5 Cables Per Phase 120/240V 1 Phase 3W and 120/208V Network >400A-1200A
81 10 07	Minimum C.T. Enclosure for 1 or 2 Cables Per Phase 120/208V 3Ø 4W and 277/480V 3Ø 4W <800 Amp
81 10 12	Minimum C.T. Enclosure for Up to 5 Cables Per Phase 120/208V 3Ø 4W and 277/480V 3Ø 4W >800A-2000A Max
81 10 32	Space Requirements for Metering Window Type Current Transformers
81 10 38	Instrument Meter Pedestal
81 10 39	Less Than 480V Self-Contained Meter Pedestal
81 10 41	Typical 400 Amp Meter Base with Class 320 Meter 120/240V 1 Phase 3W
81 20 02	Typical 200-400A Meter Base for Overhead Service
81 20 03	Multi-Meter Numbering
81 20 05	Multi-Family Dwelling Individual Metering Overhead
81 20 07	Typical Post Mounted Installation for 1 Phase Service for Mobile Home
81 20 10	Typical Meter Base for 1 Phase and 3 Phase Overhead/Underground Service 200A Max
81 20 12	1 Phase and 3 Phase 480V Self-Contained Meter Base with Loadbreak Disconnect Up to 200A



Electrical Load Data Sheet

Please Provide Two Copies of Site Plan



*Facility Name: _____ *Date: _____
 *Address: _____ *City/State/Zip: _____
 *Directions or nearest intersecting Street: _____

This sheet should be submitted in addition to the LG&E Gas Load Data Sheet, if applicable. This sheet does not fulfill the requirement of an application for service. You must contact LG&E Customer Service at (800) 331-7370 or KU Customer Service at (800) 981-0600 (residential) or (800) 383-5582 (business) to apply.

For LG&E customers, fax your completed load sheet to (502) 217-2083 or email to new.biz@lge-ku.com.

For KU customers, call the KU BSC line at (859) 367-5839 or email to BSCMoves@lge-ku.com.

Items with an asterisk * or in RED boxes are required information. Failure to provide this information may result in delays regarding your project.

Electric Service Data

Service Request Type: New Construction Existing Overhead to Underground Conversion
 Anticipated Service Date for Permanent Service: _____ Temporary Service Needed: Yes No Date: _____
 Electric Service Type: Overhead Underground (padmount) Underground (splice box LG&E) Underground (from pole KU)
 *Entrance Size: _____ A Conduit # & Diameter: _____ Conductor Size/# of Sets: _____
 Facility Type: Multi-Family Residential Commercial Industrial Municipal
 Facility Comments for Multi-Family (e.g. # of units per building): _____
 Facility Total Sq-Ft (as per building): _____ # of Floors: _____ Sq-Ft of Comfort Conditioned Area: _____
 Facility Heated with: Gas Electric Water Heating: Gas Electric Tons-A/C: _____ # of Units: _____

This facility's intended use will be (e.g. residential, office space etc.): _____

Does this project involve any of the following?

Electric Vehicle Charging: Yes No # of Level 2 (1Ø) chargers _____ # of Level 3 (3Ø) chargers _____ Total kW _____
 Distributed Generation: Yes No kW if Yes _____ Type (solar, wind, backup generator, etc.) _____
 Energy Storage: Yes No kWh if Yes _____ kWh if yes _____
 Will any resource above backfeed electricity onto the distribution system? Yes No

Load & Voltage Data

Service Types Available					
Please Check Type					
Service Voltage/Type		LG&E		KU	
		OH	UG	OH	UG
<input type="checkbox"/> 120/240V	1Ø 3W	YES	YES	YES	YES
<input type="checkbox"/> 120/208V	3Ø 4W	YES	YES	YES	YES
<input type="checkbox"/> 240V	3Ø 3W	YES	NO	NO	NO
<input type="checkbox"/> 120/240V	3Ø 4W	NO	NO	YES	YES
<input type="checkbox"/> 277/480V	3Ø 4W	NO	YES	YES	YES
<input type="checkbox"/> 480V	3Ø 3W	YES	NO	NO	NO
OTHER: _____					

What will the true estimated peak demand for this service be in _____ kW?

Connected Loads	1 Phase kW	3 Phase kW
Space Heating	_____	_____
A/C Heat Pump	_____	_____
Air Handler	_____	_____
Lighting	_____	_____
Water Heating	_____	_____
Cooking	_____	_____
Refrigeration	_____	_____
Welding +	_____	_____
Misc./Recept/LEV	_____	_____
Total New Load	_____	_____
Existing Load	_____	_____
Total Load	_____	_____

+ may require special consideration

Motor Data:

Largest Motor: _____ Reduced Start: Yes No Type if Yes: _____
 HP: _____ Voltage: _____ Phase _____ Part Winding & Ratio _____ Wye-Delta
 FLA: _____ LRA: _____ Solid State Ramp Setting % _____ Current Limit % _____
 Other, please describe _____ Autotransformer & Tap Setting % _____

Contact Information *

*Customer/Owner: _____ *Contractor/Developer: _____
 *Phone: _____ Email: _____ *Phone: _____ Email: _____
 *Address: _____ *Address: _____
 *City/State/Zip: _____ *City/State/Zip: _____
 Comments: _____
 *Submitted By: _____ Date: _____

NESC SECTIONS 234 AND 351 (NESC 2017)

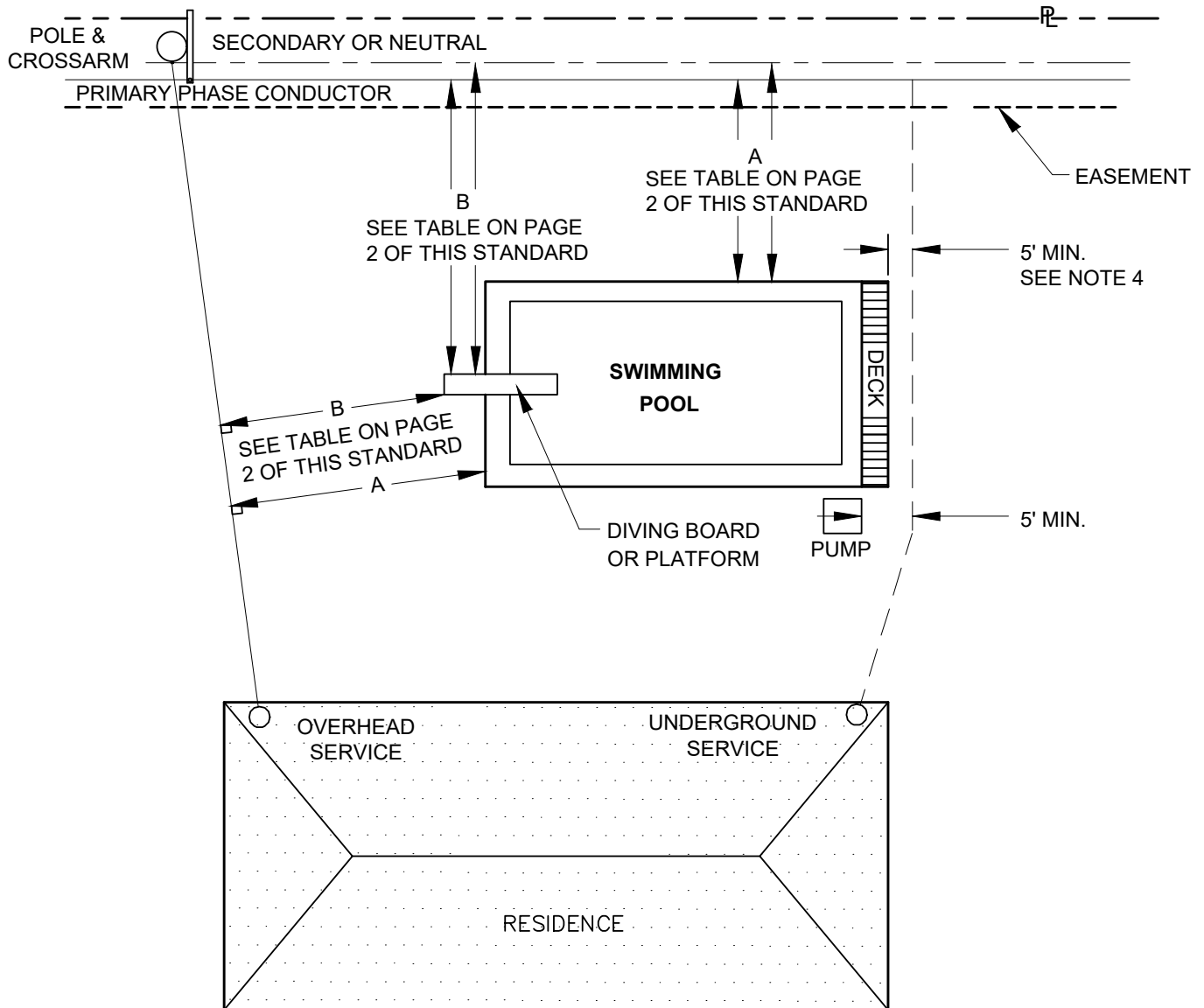

APPLICATION:

These clearance requirements apply to all pools and also to supervised swimming areas including beaches, waterways, etc. where swimming is allowed and rescue poles are used. For unsupervised swimming in other water areas, Rule 232 (standard 02 10 06) applies. Contact the Standards Group for clearances to lines greater than 22kV phase-to-ground. Exception: These clearances do not apply to pools that are fully enclosed by a solid or screened non-retractable permanent structure.

NOTES:

1. Clearance to each conductor in the pool area must be checked. The clearances listed in this standard are **minimums**. Additional clearance may be required for future changes in grade, leaning poles, etc. Vertical clearances to overhead lines apply under whichever conditions of conductor temperature and loading produce the closest approach:
A) 120°F, no wind, final sag; B) Maximum operating temperature, no wind, final sag; C) 32°F, with 1/4" ice, no wind, final sag; D) Minimum operating temperature, no wind, initial sag.
2. Installation of new conductors over existing pools should be avoided wherever possible, even when NESC clearance is obtainable. Pools installed under existing lines which result in a code violation must be brought in compliance by relocation of the pool or line or, if necessary, ensuring adequate clearance over the pool. It is normally the customer's responsibility to correct code violations caused by placing a pool under existing utility lines.
3. Multiplex service drops (triplex) less than 750 V are allowed lesser clearances under the NESC but must not be less than 10' horizontally from the edge of pools or diving platforms (234E1 Exception 2).
4. The swimming pool, decking, and auxiliary equipment must have a 5' minimum separation from underground cables.

234E1. Clearance of wires, conductors, cables, or unguarded rigid live parts installed over or near swimming areas with no wind displacement.

1. Swimming Pools

Where wires, conductors, cables, or unguarded rigid live parts are over a swimming pool or the surrounding area, the clearances in any direction shall be not less than those shown in Table 234-3 and illustrated in Figure 234-3.

EXCEPTION 1: This rule does not apply to a pool fully enclosed by a solid or screened permanent structure.

EXCEPTION 2: This rule does not apply to communication conductors and cables, effectively grounded surge-protection wires, neutral conductors meeting Rule 230E1, guys and messengers, supply cables meeting Rule 230C1, and supply cables of 0 to 750 V meeting Rule 230C2 or 230C3 when these facilities are 3m (10ft) or more horizontally from the edge of the pool, diving platform, diving tower, water slide, or other fixed, pool-related structures.

351C. Other conditions 1. Swimming pools (in-ground)

Supply cable should not be installed within 1.5m (5ft) horizontally of a swimming pool or its auxiliary equipment.

2. Buildings and other structures

Cable should not be installed directly under the foundations of buildings or other structures, such as above ground swimming pools, tanks, toolsheds, etc.

OVERHEAD
REQUIREMENTS

UNDERGROUND
REQUIREMENTS

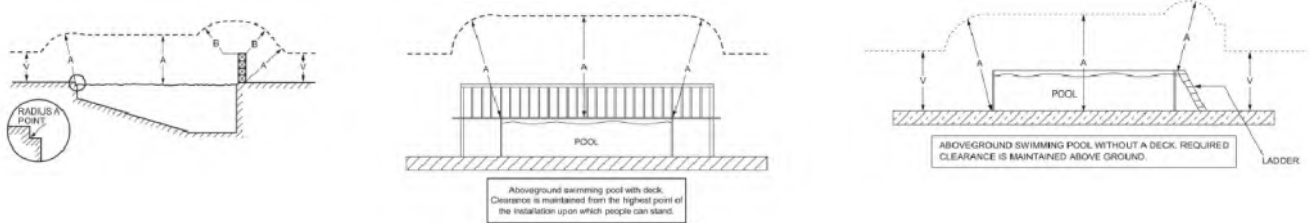

NESC Table 234-3--Clearance of wires, conductors, cables, or unguarded rigid live parts over or near swimming pools (1)
(Voltages are phase to ground for effectively grounded circuits and those other circuits where all ground faults are cleared by promptly de-energizing the faulted section, both initially and following subsequent breaker operations. See the definitions section for voltages of other systems. Clearances are with no wind displacement. See Rules 234E1, 234E2, and 234H4.)

Note: A, B, and V are shown in associated figures.	Insulated communication conductors and cables; messengers; overhead shield/surge protection wires; effectively grounded guys; ungrounded portions of guys exposed to 0 to 300 V (2)(4); neutral conductors meeting Rule 230E1; supply cables meeting Rule 230C1 (ft)	Unguarded rigid live parts, 0 to 750 V; noninsulated communication conductors; supply cables of 0 to 750 V meeting Rule 230C2 or 230C3; ungrounded portions of guys meeting Rules 215C2 and 279A1 exposed to open supply conductors of over 300 V to 750 V (1)(4) (ft)	Supply cables over 750 V meeting Rule 230C2 or 230C3; open supply conductors, 0 to 750 V (3) (ft)	Unguarded rigid live parts over 750 V to 22 kV; ungrounded portions of guys meeting Rules 215C2 and 279A1 exposed to over 750V to 22 kV (1)(4) (ft)	Open supply conductors, over 750 V to 22 kV (ft)
A. Clearance in any direction from the water level, edge of pool, base of diving platform or anchored raft	22.0	22.5	23.0	24.5	25.0
B. Clearance in any direction to the diving platform, tower, water slide, or other fixed, pool-related structures	14.0	14.5	15.0	16.5	17.0
V. Vertical clearances over adjacent land	Clearance shall be as required by Rule 232. See standard# 02 10 06				

1. The portion(s) of span guys between guy insulators and the portion(s) of anchor guys above guy insulators that are not effectively grounded shall have clearances based on the highest voltage to which they may be exposed due to a slack conductor or guy.
2. The portion of anchor guys below the lowest insulator meeting Rules 279A1 and 215C2a may have the same clearance as effectively grounded guys.
3. Does not include neutral conductors meeting Rule 230E1.
4. These clearance values also apply to guy insulators.

SEE DRAWING ON LOWER
LEFT CORNER OF PAGE #1
FOR DETAIL INSTALLATION
OF CONCRETE PIPE.

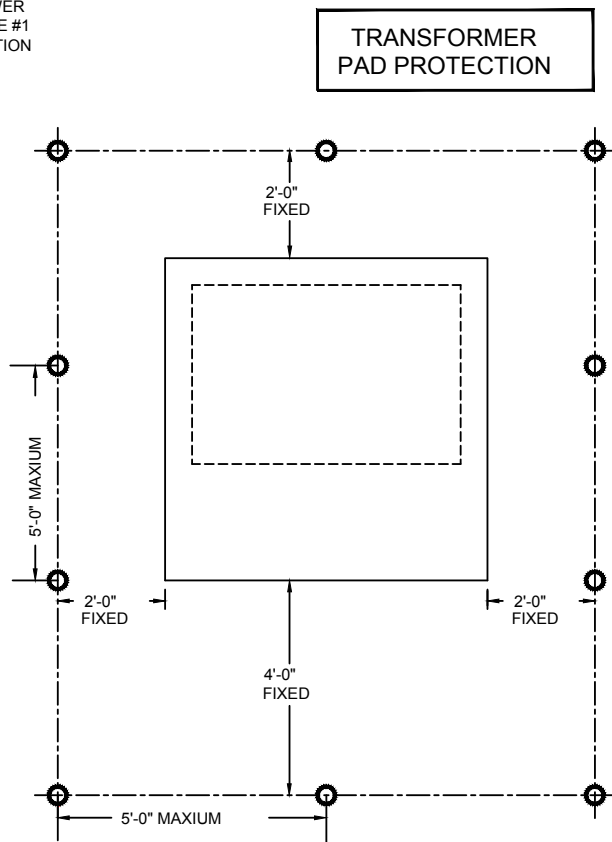

INSTALLATION OF PIPE PROTECTION TO BE INSTALLED WITH FIXED CLEARANCES AS FOLLOWS: SIZE OF PAD PLUS 2'-0" CLEARANCE IN REAR AND ON BOTH SIDES OF PAD, WITH 4'-0" CLEARANCE IN FRONT OF PAD. THIS ESTABLISHES THE AREA TO BE PROTECTED. DISTANCE BETWEEN PROTECTION POINTS WILL BE EQUALLY SPACED WITH A MAXIMUM OF 5'-0" SEPARATION.

SEE DRAWING ON LOWER
LEFT CORNER OF PAGE #1
FOR DETAIL INSTALLATION
OF CONCRETE PIPE.

**SWITCHGEAR/SWITCHGEAR AND TRANSFORMER
PROTECTION**

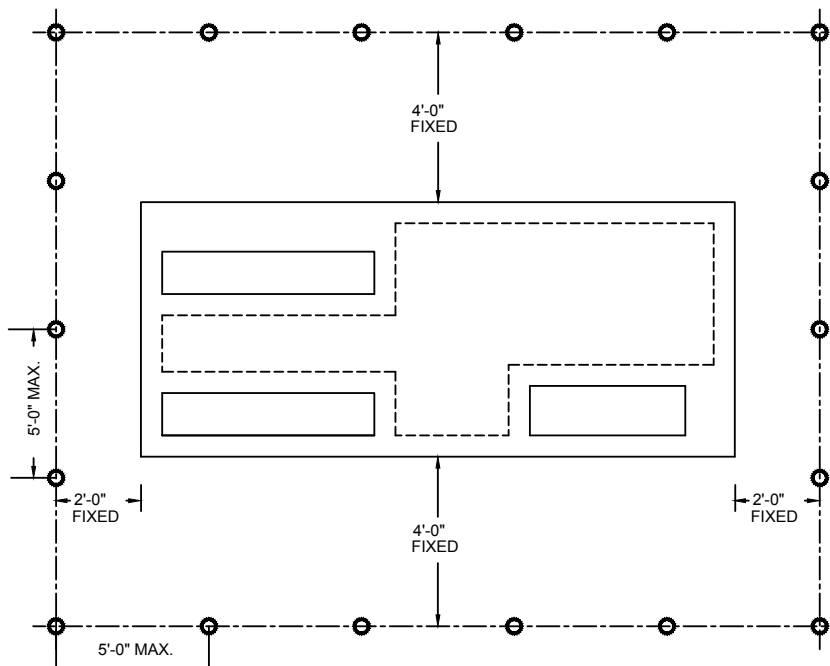

INSTALLATION OF PIPE PROTECTION TO BE INSTALLED WITH FIXED CLEARANCES AS FOLLOWS: SIZE OF PAD PLUS 4'-0" CLEARANCE BOTH FRONT AND BACK AND 2'-0" CLEARANCE ON BOTH SIDES. THIS ESTABLISHES THE AREA TO BE PROTECTED. DISTANCE BETWEEN PROTECTION POINTS WILL BE EQUALLY SPACED WITH A MAXIMUM OF 5'-0" SEPARATION.

NESC SECTION 234 AND 235 (NESC 2017)

NOTE:

1. CUSTOMER POLE HEIGHT AND LOCATION TO BE SPECIFIED BY UTILITY. 5' MINIMUM CLEARANCE REQUIRED BETWEEN CUSTOMER POLE AND MOBILE HOME AND ANY PROJECTIONS THEREFROM.
2. GROUND CLEARANCE SHOULD EXCEED NESC MINIMUMS TO THE EXTENT PRACTICAL TO ENSURE COMPLIANCE UNDER ALL LOADING CONDITIONS THROUGHOUT THE LIFE OF THE INSTALLATION. **SEE STANDARD 02 10 10** FOR NESC GROUND CLEARANCE REQUIREMENTS. SERVICE LINES NOT ENGINEERED AND SAGGED DURING INSTALLATION SHOULD NOT EXCEED 100' IN LENGTH AND MEASURED GROUND CLEARANCE SHOULD EXCEED NESC REQUIREMENTS AT ALL LOCATIONS IN THE SPAN BY A MINIMUM OF 12 INCHES.

NOTE:

CUSTOMER'S FACILITIES TO BE INSTALLED IN ACCORDANCE WITH ALL NATIONAL, STATE AND LOCAL CODES OR REGULATIONS.

ALL MATERIAL AND EQUIPMENT WITH THE EXCEPTION OF THE SERVICE DROP AND ATTACHMENT CLAMP, SERVICE ENTRANCE CONNECTIONS AND ELECTRIC METER ARE TO BE PROVIDED AND INSTALLED BY THE CUSTOMER.

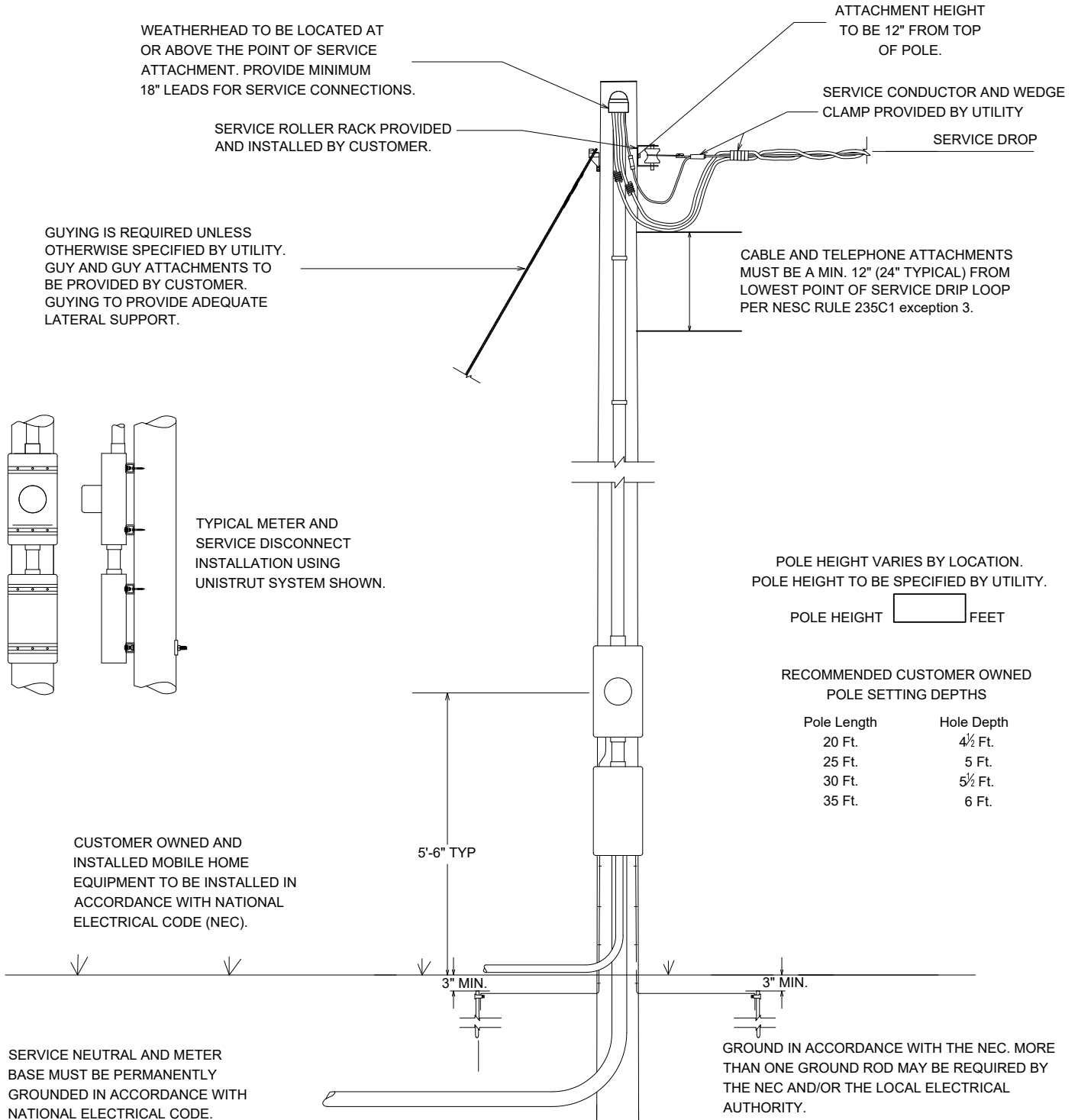

NESC SECTION 235 REQUIREMENTS (NESC 2017)

NOTE:

1. CUSTOMER POLE HEIGHT AND LOCATION TO BE SPECIFIED BY UTILITY.
2. GROUND CLEARANCE SHOULD EXCEED NESC MINIMUMS TO THE EXTENT PRACTICAL TO ENSURE COMPLIANCE UNDER ALL LOADING CONDITIONS THROUGHOUT THE LIFE OF THE INSTALLATION. **SEE STANDARD 02 10 10** FOR NESC GROUND CLEARANCE REQUIREMENTS. SERVICE LINES NOT ENGINEERED AND SAGGED DURING INSTALLATION SHOULD NOT EXCEED 100' IN LENGTH AND MEASURED GROUND CLEARANCE SHOULD EXCEED NESC REQUIREMENTS AT ALL LOCATIONS IN THE SPAN BY A MINIMUM OF 12 INCHES.

NOTE:

CUSTOMER'S FACILITIES TO BE INSTALLED IN ACCORDANCE WITH ALL NATIONAL, STATE AND LOCAL CODES OR REGULATIONS.

ALL MATERIAL AND EQUIPMENT WITH THE EXCEPTION OF THE SERVICE DROP AND ATTACHMENT CLAMP, SERVICE ENTRANCE CONNECTIONS AND ELECTRIC METER ARE TO BE PROVIDED AND INSTALLED BY THE CUSTOMER.

WEATHERHEAD TO BE LOCATED AT OR ABOVE THE POINT OF SERVICE ATTACHMENT. PROVIDE MINIMUM 18" LEADS FOR SERVICE CONNECTIONS.

ATTACHMENT HEIGHT TO BE 12" FROM TOP OF POLE.

SERVICE ROLLER RACK PROVIDED AND INSTALLED BY CUSTOMER.

CUSTOMER LOAD

SERVICE DROP UTILITY

SERVICE CONDUCTOR AND WEDGE CLAMP PROVIDED BY UTILITY

CABLE AND TELEPHONE ATTACHMENTS MUST BE A MIN. 12" (24" TYPICAL) FROM LOWEST POINT OF SERVICE DRIP LOOP PER NESC RULE 235C1 exception 3.

TYPICAL CUSTOMER RISER AND OVERHEAD FEED SHOWN.

CUSTOMER CONSTRUCTION AND CLEARANCES INCLUDING ALL CUSTOMER OWNED AND INSTALLED EQUIPMENT TO BE INSTALLED IN ACCORDANCE WITH NATIONAL ELECTRICAL CODE (NEC).

CUSTOMER PROVIDED GUYING MAY BE REQUIRED BY UTILITY.

POLE HEIGHT VARIES BY LOCATION. POLE HEIGHT TO BE SPECIFIED BY UTILITY.

POLE HEIGHT FEET

RECOMMENDED CUSTOMER OWNED POLE SETTING DEPTHS

Pole Length	Hole Depth
20 Ft.	4½ Ft.
25 Ft.	5 Ft.
30 Ft.	5½ Ft.
35 Ft.	6 Ft.

TYPICAL METER AND SERVICE DISCONNECT INSTALLATION USING UNISTRUT SYSTEM SHOWN.

SERVICE NEUTRAL AND METER BASE MUST BE PERMANENTLY GROUNDED IN ACCORDANCE WITH NATIONAL ELECTRICAL CODE.

5'-6" TYP

3" MIN.

3" MIN.

GROUND IN ACCORDANCE WITH THE NEC. MORE THAN ONE GROUND ROD MAY BE REQUIRED BY THE NEC AND/OR THE LOCAL ELECTRICAL AUTHORITY.

NOTE:

ALL MATERIALS EXCEPT THE METER ARE TO BE FURNISHED AND INSTALLED BY THE CONTRACTOR. WORK MUST CONFORM TO NATIONAL ELECTRIC CODE AND BE APPROVED BY THE AUTHORIZED INSPECTION AUTHORITY

MAXIMUM DISTANCE FROM UTILITY SUPPLY POLE - 75'. MINIMUM DISTANCE FROM UTILITY SUPPLY POLE - 15'.

THIS STANDARD DOES NOT APPLY WHEN THE UTILITY SERVICE CROSSES A STREET /HIGHWAY TO SERVE A TEMPORARY SERVICE POLE. ADDITIONAL HEIGHT WILL BE REQUIRED FOR TEMPORARY SERVICE POLE. IN SUCH CASES CONTACT YOUR SERVICE LOCATOR FOR ADDITIONAL REQUIREMENTS.

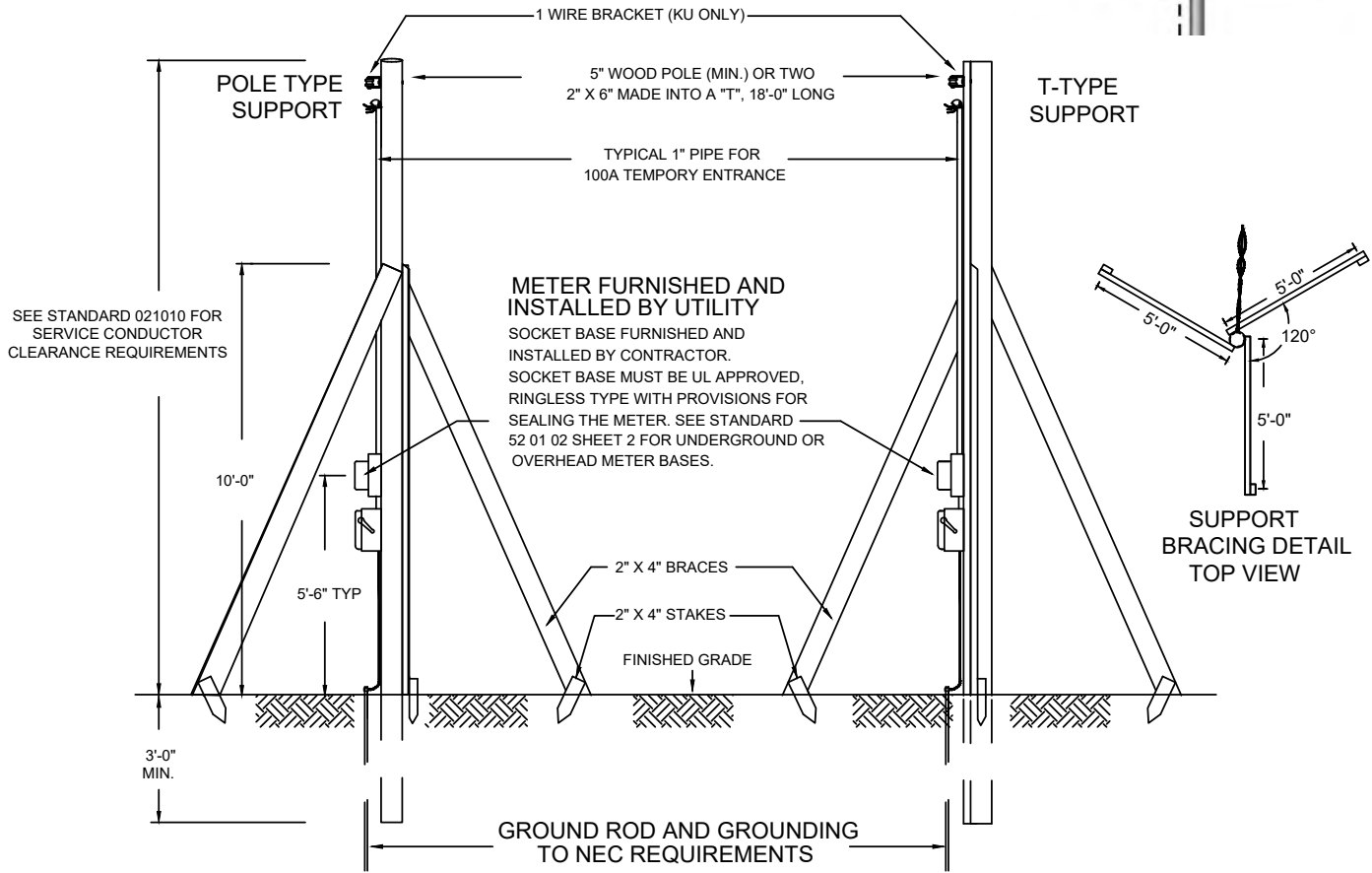
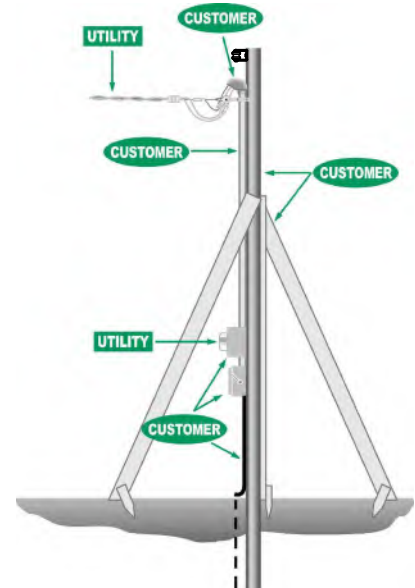

IMPORTANT

INSTALLATION AND SUPPORT DETAIL FOR OVERHEAD 1Ø 3-WIRE 120/240V 100 TEMPORARY SERVICE UP TO 200A. CONTACT YOUR SERVICE LOCATOR FOR LARGER SIZE TEMPORARIES

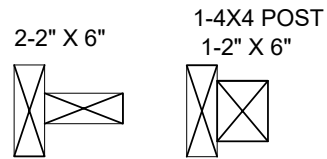

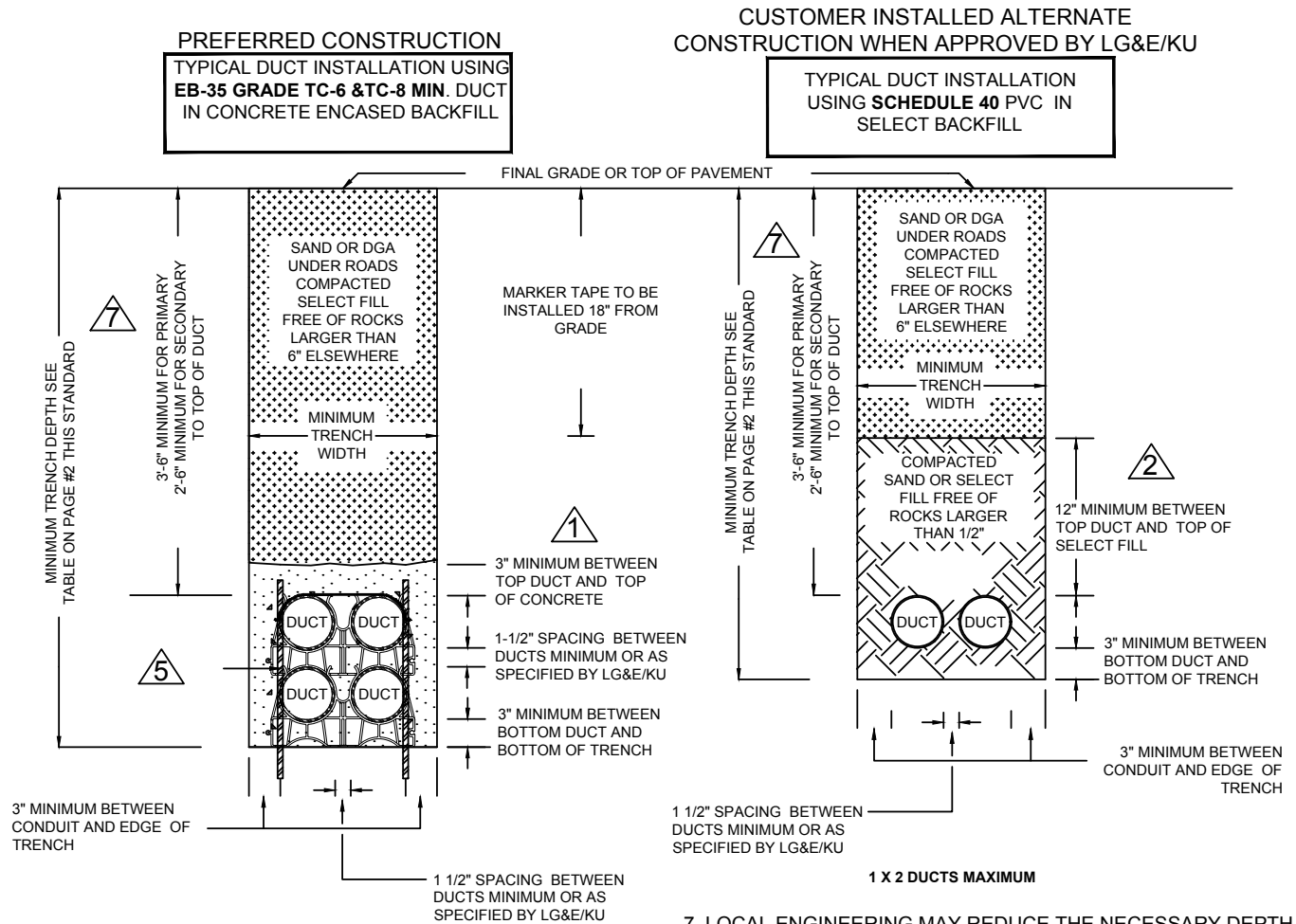

GENERAL NOTES:

1. CONCRETE ENCASED DUCT: ALL DUCT TO BE A MINIMUM NEMA EB-35 GRADE TC-6 & TC-8.
2. SELECT FILL ENCASED DUCT: ALL CUSTOMER INSTALLED DUCT IN SELECT FILL TO BE SCHEDULE 40 GRADE, NEMA TC-2 AND UL-651.
3. MINIMUM TRENCH WIDTH AND DEPTH DIMENSIONS ARE BASED ON WORST CASE PVC OUTSIDE DIMENSIONS FOR THE VARIOUS SIZE DUCTS. SEE CHARTS ON PAGE #2.
4. IF MORE THAN ONE SIZE DUCT IS USED IN A TRENCH IT WILL BE NECESSARY TO CALCULATE NEW MINIMUM WIDTH AND DEPTH DIMENSIONS. THESE DIMENSIONS WILL BE BASED ON A MINIMUM CLEARANCE OF 3" TO SIDES, TOP OR BOTTOM WITH A MINIMUM OF 1 1/2" BETWEEN DUCTS OR AS SPECIFIED BY LG&E/KU. SEE CHART ON PAGE #2 FOR TYPICAL OUTSIDE DIMENSIONS FOR DUCT.
5. DUCT IS TO BE ANCHORED PRIOR TO POURING CONCRETE. 1/2" STEEL REBAR AND TIE WIRES ARE NECESSARY IN CONCRETE FILL TO KEEP DUCTS FROM FLOATING. DUCT SPACERS, STEEL RODS AND TIES TO BE PLACED +/- 5'-0" APART. DISCONTINUOUS CONCRETE POURS ARE TO BE REINFORCED WITH 1/2" REBAR AT THEIR JUNCTION. COUPLINGS ARE REQUIRED TO BE STAGGERED 12" LONGITUDINALLY TO ENSURE CONCRETE AGGREGATE FILLS VOIDS BETWEEN CONDUITS.
6. MARKER TAPE SHOULD BE INSTALLED 18" FROM FINAL GRADE.

7. LOCAL ENGINEERING MAY REDUCE THE NECESSARY DEPTH FOR PRIMARY CIRCUITS BY UP TO 6" ON A CASE BY CASE BASIS. ADDITIONAL DEPTH WILL BE REQUIRED WHERE 48" OR GREATER RADIUS ELBOWS ARE SPECIFIED AT RISERS.
8. CONCRETE SHALL BE A MINIMUM 3500 PSI WITH A 4"-6" SLUMP AND #57 AGGREGATE. CONCRETE MAY BE REQUIRED TO BE DYED RED.

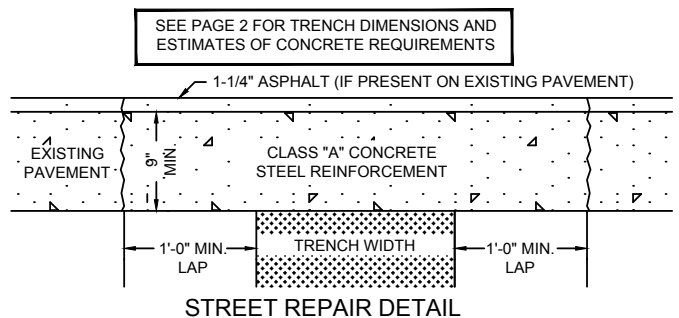

NOTES:

- DEPTH OF CONCRETE SHOULD MATCH THAT OF THE EXISTING CONCRETE IF GREATER THAN 9". SIDEWALK IS POURED BACK ONLY 4" DEEP WITH NO REINFORCEMENT.
- ALL FILL MATERIAL MUST BE THOROUGHLY COMPACTED PRIOR TO POURING CONCRETE FOR ROAD.
- BACKFILL AND RESTORATION REQUIREMENTS MAY BE MODIFIED BY PERMITTING AUTHORITY WHEN IN ROAD RIGHT OF WAY.

MINIMUM TRENCH DIMENSIONS AND CONCRETE REQUIREMENTS FOR PRIMARY DUCT BANKS
(FOR SECONDARY BANKS SUBTRACT 12" FROM THE DEPTH COLUMN)

Duct Size (")	Rows	Columns	Width (")	Depth (")	Approx. Concrete (Cu-Yds/100')
2	1	1	9	48	3.4
3			10	49	3.9
4			11	50	4.4
5			12	51	4.9
6			13	52	5.5
2	1	2	13	48	4.8
3			15	49	5.7
4			17	50	6.6
5			19	51	7.5
6			21	52	8.5
2	1	3	17	48	6.2
3			20	49	7.5
4			23	50	8.8
5			26	51	10.2
6			29	52	11.6
2	1	4	20	48	7.3
3			25	49	9.3
4			29	50	11.0
5			33	51	12.8
6			37	52	14.6
2	2	1	9	52	4.2
3			10	54	4.9
4			11	56	5.7
5			12	58	6.5
6			13	60	7.3
2	2	2	13	52	5.9
3			15	54	7.1
4			17	56	8.4
5			19	58	9.7
6			21	60	11.1
2	2	3	17	52	7.6
3			20	54	9.3
4			23	56	11.2
5			26	58	13.0
6			29	60	14.9
2	2	4	20	52	8.9
3			25	54	11.5
4			29	56	13.9
5			33	58	16.2
6			37	60	18.7
2	3	1	9	56	5.0
3			10	59	5.9
4			11	62	7.0
5			12	65	8.0
6			13	68	9.1
2	3	2	13	56	7.0
3			15	59	8.5
4			17	62	10.2
5			19	65	11.9
6			21	68	13.7
2	3	3	17	56	9.0
3			20	59	11.1
4			23	62	13.5
5			26	65	15.8
6			29	68	18.3
2	3	4	20	56	10.5
3			25	59	13.7
4			29	62	16.7
5			33	65	19.7
6			37	68	22.9
2	4	1	9	59	5.6
3			10	64	7.0
4			11	68	8.3
5			12	72	9.5
6			13	76	10.9
2	4	2	13	59	7.8
3			15	64	10.0
4			17	68	12.0
5			19	72	14.1
6			21	76	16.3
2	4	3	17	59	10.0
3			20	64	13.0
4			23	68	15.8
5			26	72	18.6
6			29	76	21.6
2	4	4	20	59	11.6
3			25	64	16.0
4			29	68	19.6
5			33	72	23.1
6			37	76	27.0

ALL ENCASED DUCT TO BE NEMA EB-35 GRADE TC-6 & TC-8
MIN.

FOR LARGER OR
NON-STANDARD
INSTALLATIONS CONTACT
STANDARDS GROUP.

DUCT SIZE & DIMENSION CHART

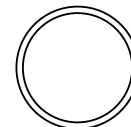

Duct Size	Outside Diameter (")
2"	2.375
3"	3.5
4"	4.5
5"	5.5625
6"	6.5625

IIN# 0480127 Standard Fiberglass Box Pad Up To 75KVA
37"x43"x24" Single phase fiberglass pad mount transformer box pad with 22"x24" opening. This is the standard transformer pad for use with single phase transformers up to 75KVA.

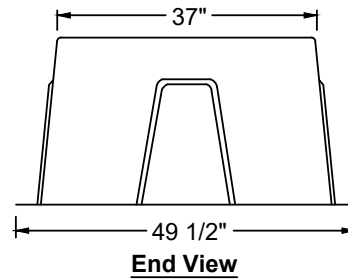
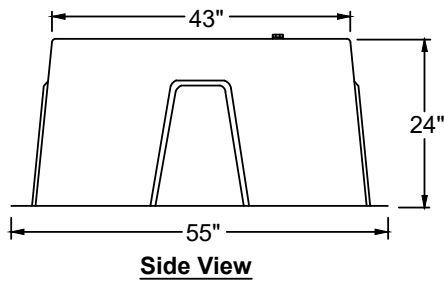
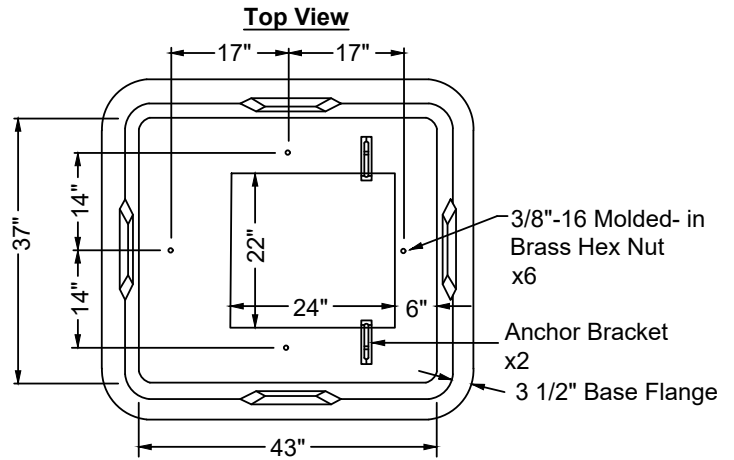

3/8"- 1 1/2" Penta-head Bolt
x4

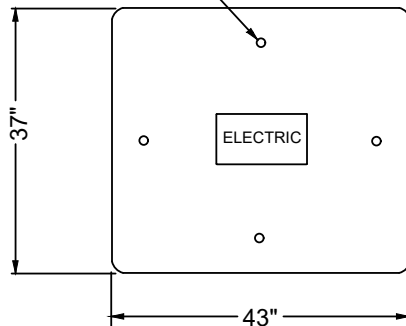

IIN# 1565660 Cover for Standard Fiberglass Box Pad
37"x43" Exterior cover for transformer box pad IIN# 0480127. Includes 4 - 3/8" X 1 1/2" stainless steel penta-head bolts.

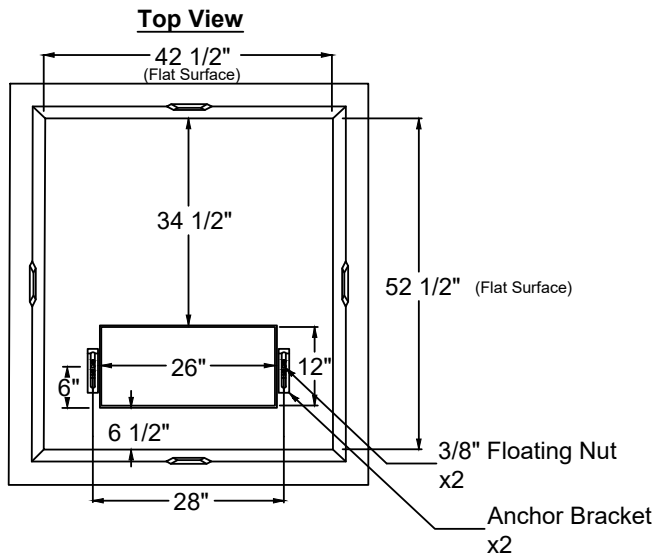

OPTION 1

IIN# 3020373 Large Fiberglass Box Pad 100KVA And Above

42"x52"x16" Single phase fiberglass pad mount transformer box pad with 26"x12" opening. This transformer pad is for use with 100KVA single phase transformers and above.

It can also be used to raise or level existing smaller concrete and fiberglass box pads, if adequate cable slack is present. In this application it can be nested over an existing box pad with only a small amount of excavation around the perimeter of the pad. This eliminates the need to completely remove the original pad which could damage primary and secondary cables/conduits.

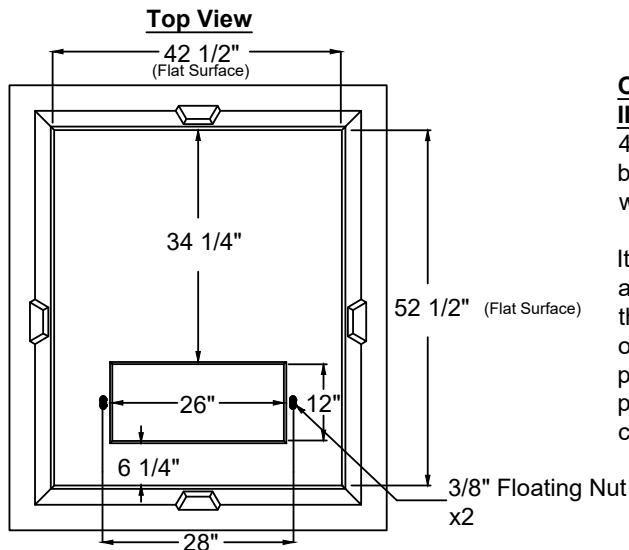
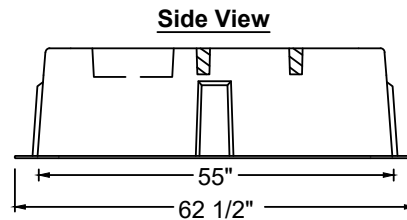
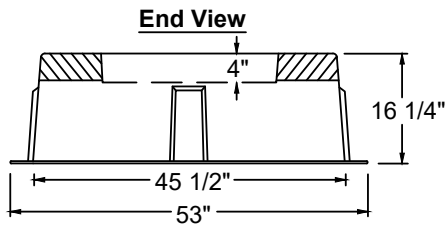

OPTION 2

IIN# 3031516 Large Fiberglass Box Pad 100KVA And Above

42"x52"x32" Single phase fiberglass pad mount transformer box pad with 26"x12" opening. This transformer pad is for use with 100KVA single phase transformers and above.

It can also be used to raise or level existing smaller concrete and fiberglass box pads, if adequate cable slack is present. In this application it can be nested over an existing box pad with only a small amount of excavation around the perimeter of the pad. This eliminates the need to completely remove the original pad which could damage primary and secondary cables/conduits.

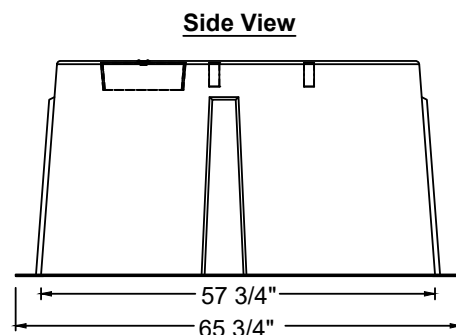
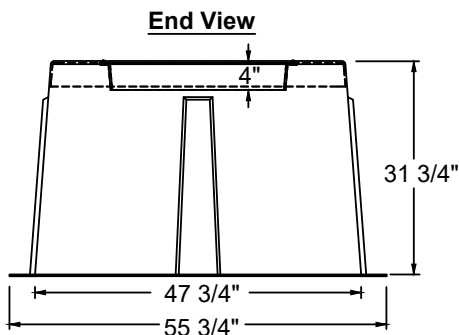

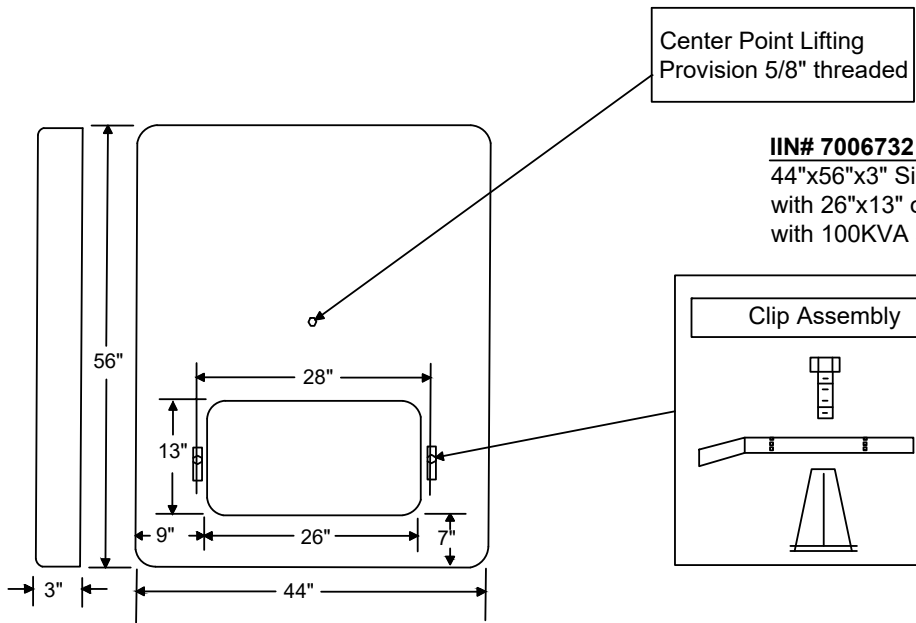

IIN# 7006732 Composite Flat Pad Up To 100KVA
44"x56"x3" Single phase pad mount transformer flat pad with 26"x13" opening. This transformer pad is for use with 100KVA single phase transformers and smaller.

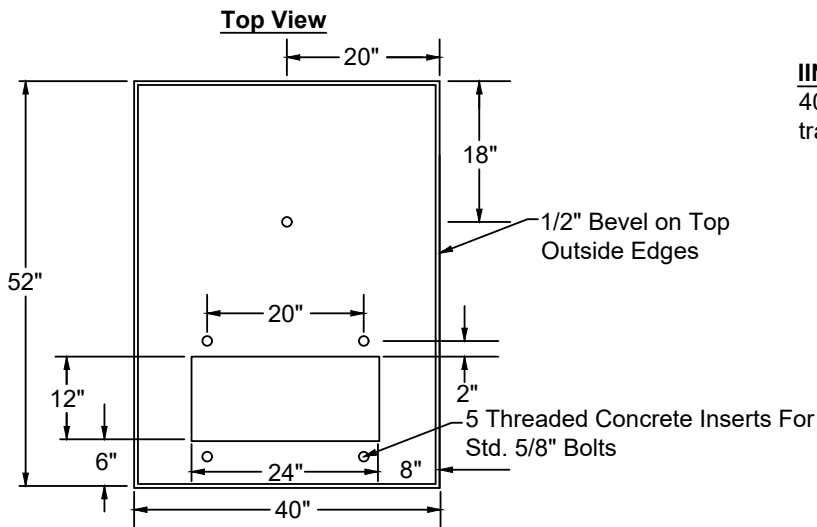
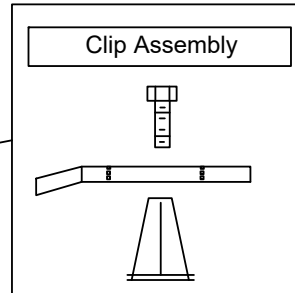

IIN# 7001161 Concrete Flat Pad Up to 250KVA
40"x52"x4" Single phase concrete pad mount transformer flat pad with 12"x24" opening.

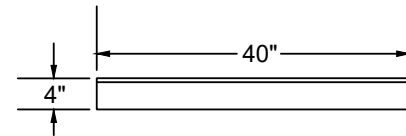

End View

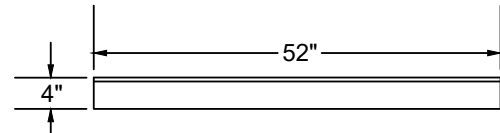

Side View

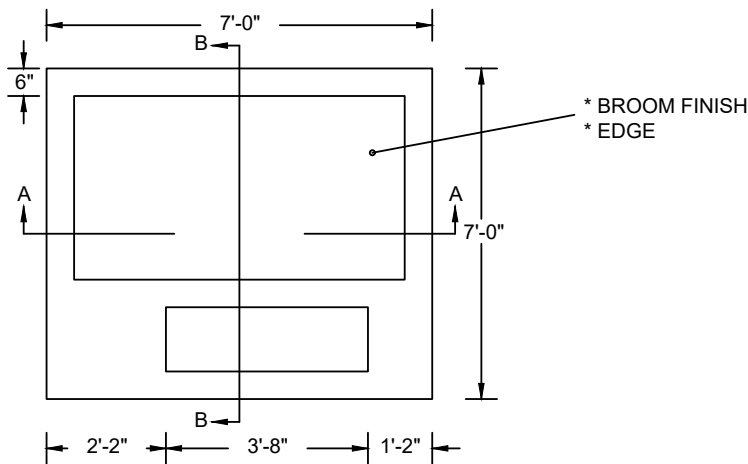

PLAN VIEW

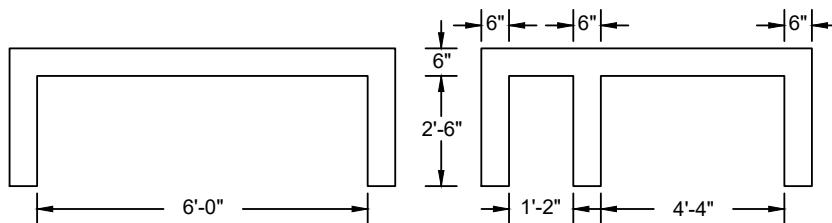

SECTION A-A

SECTION B-B

84\"/>

NOTES:

1. CONCRETE: 28 DAY COMPRESSIVE STRENGTH $f_c = 5,000$ psi
2. STEEL REINFORCEMENT: ASTM A-615, GRADE 60 (CONTACT STANDARDS GROUP FOR CURRENT VERSION)
3. COVER TO STEEL-1" MINIMUM
4. T-PADS ARE DESIGNED TO MEET ASTM C858 AND ACI 318 WITH AASHTO HS-20 LOADING
5. SEE STANDARD 420604 FOR DUCT DETAIL
6. PAD REINFORCEMENT DESIGNED TO SUPPORT A TOTAL OF 17,000 LBS.
7. LG&E SERVICE AREAS MUST USE A PRECAST PAD. POURED PADS ARE NOT ACCEPTABLE.

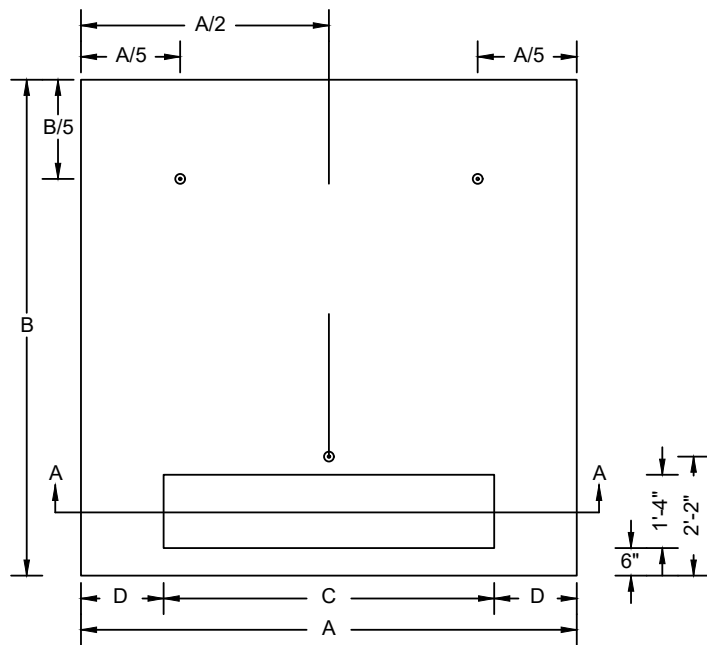

PLAN VIEW

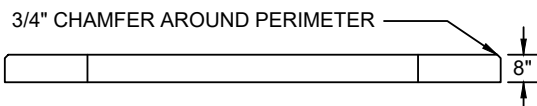

SECTION A-A

KU PADS

NOTES:

1. CONCRETE: 28 DAY COMPRESSIVE STRENGTH $f_c = 4,500$ psi
2. STEEL REINFORCEMENT: ASTM A-615, GRADE 60 (CONTACT STANDARDS GROUP FOR CURRENT VERSION)
3. MINIMUM REINFORCING COVER = 1"
4. TRANSFORMER PADS ARE DESIGNED TO MEET ALL KU SPECIFICATIONS
5. PAD SHALL CONTAIN 1/2" STEEL REBAR ON 5" CENTERS, 4"X4" 4/4 WIRE MESH OR EQUIVALENT.
6. KU SERVICE AREAS MAY USE EITHER A PRECAST PAD OR A PAD POURED ON SITE.
7. SEE STANDARD 420604 FOR DUCT DETAIL.

KVA	A	B	C	D	WEIGHT
0-500	7-6"	7-0"	4-6"	1-6"	4650 LBS
750-3000	9-0"	9-0"	5-0"	2-0"	7435 LBS

CABLE ENTRANCE WINDOW

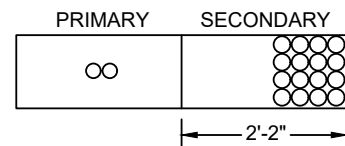

TYPICAL PAD INSTALLATION BY CUSTOMER FOR 3Ø TRANSFORMERS 75KVA TO 3000KVA

PLAN VIEW

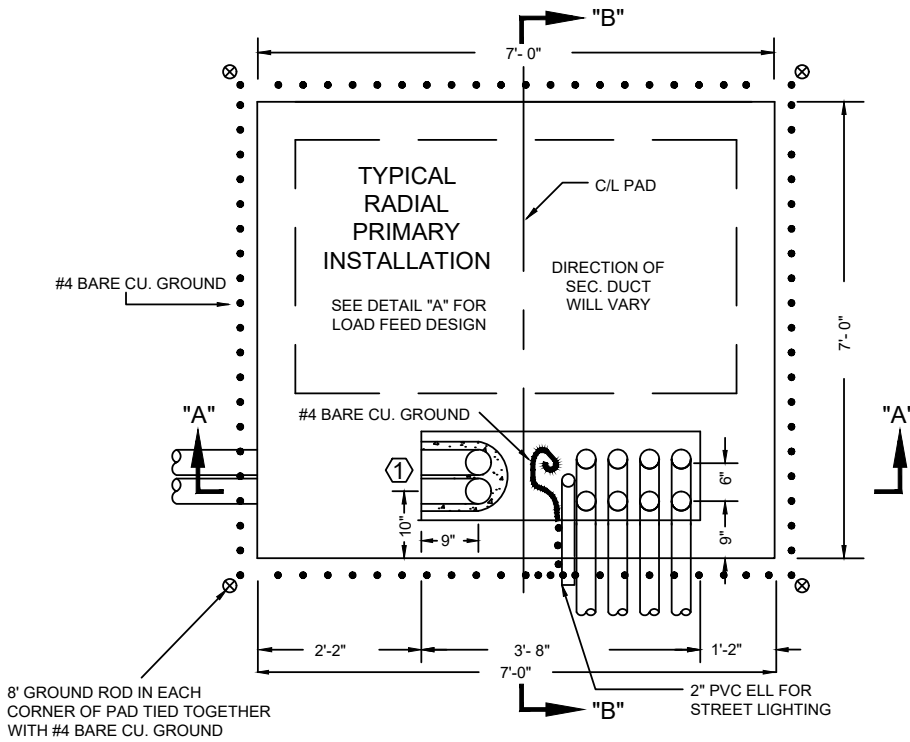

CUSTOMER REQUIREMENTS

1. MINIMUM 2 DUCTS FOR RADIAL PRIMARY, 3 DUCTS FOR LOOP THROUGH PRIMARY, INSTALLATIONS. SIZE AND DIRECTION TO BE SPECIFIED BY LG&E BUT SHALL NOT BE SMALLER THAN 4".
2. SECONDARY CONDUIT SHALL BE STUBBED OUT A MINIMUM OF 2' BEYOND PAD, EVEN FOR DIRECT BURIAL SERVICES.
3. PRIMARY DUCT ELLS TO COMPLY WITH NEMA STANDARDS EB GRADE TC-8 SCH. 40 MIN. DUCT ELLS TO BE PVC 36" LONG RADIUS MINIMUM.
4. SECONDARY CABLES (CUSTOMER SERVICE) LIMITED TO EIGHT (8) SETS OF CABLES 500MCM OR BELOW SIX (6) SETS OF CABLES OVER 500MCM. REFERENCE DRAWING 42 06 10 FOR INSTALLATIONS EXCEEDING ABOVE LIMITATIONS.
5. MINIMUM CLEARANCES OF 10'-0" FRONT AND 3'-0" SIDE AND BACK TO ANY OBSTRUCTION OR PLANTINGS.

NOTES

- a. PROTECTIVE BALLARDS MAY BE REQUIRED. SEE STANDARD #04 10 04 FOR DETERMINATION OF PROTECTION TO BE MADE AFTER CURB AND DRIVING LANES ARE IN.
- b. LG&E SERVICE AREAS MUST USE A PRECAST CONCRETE PAD, A POURED PAD IS NOT ACCEPTABLE. SEE STANDARD 420603 FOR REQUIRED PRECAST TRANSFORMER PAD INFORMATION.
- c. BEFORE INSTALLING PAD NOTIFY THE LG&E/KU DESIGN TECHNICIAN YOU ARE WORKING WITH FOR INSPECTION OF SITE, PLACEMENT OF DUCT ELLS, GROUND WIRE AND GROUND RODS. A MINIMUM OF ONE WORKING DAY NOTICE IS REQUIRED.

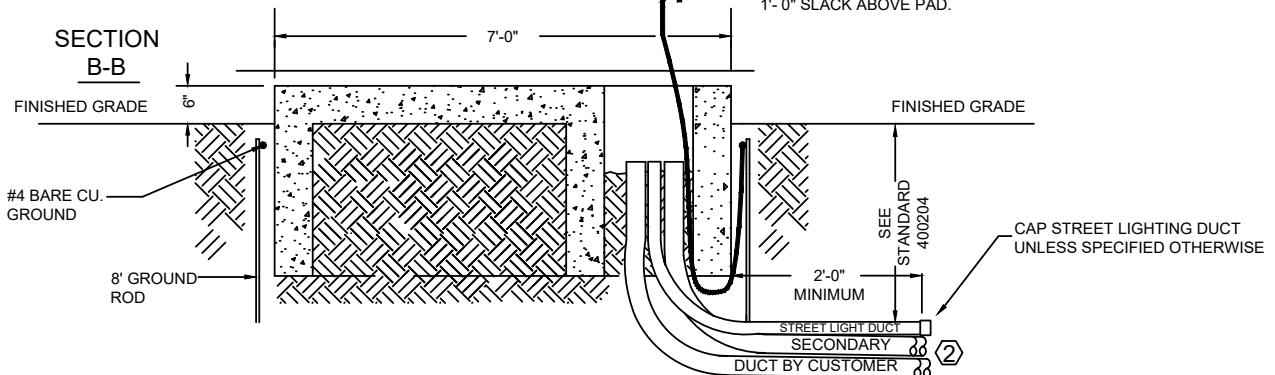
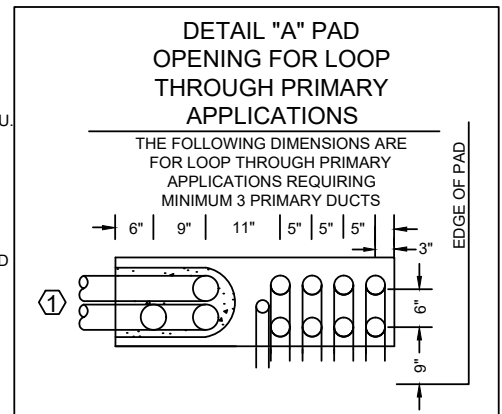
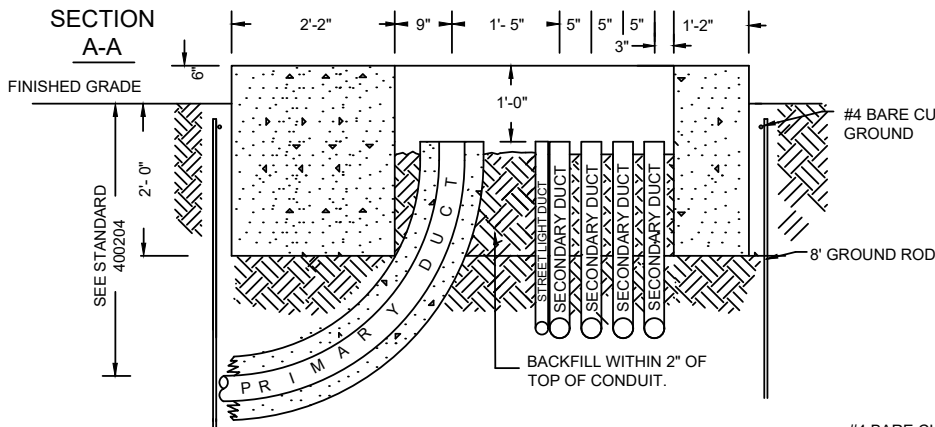

Padmount transformers shall be located in accordance with the following guidelines with respect to exterior building walls. These guidelines are based on insurance industry recommended practices for the location of oil-filled transformers outdoors. The building owner and/or tenants fire insurance carrier or local inspection authority may have requirements that are more stringent and/or requirements that restrict the proximity of the equipment to doorways, fire exits, etc. It is the Customer's responsibility to determine the acceptability of the proposed location to those authorities.

TRANSFORMER		
TYPE	KVA RANGE	MINIMUM SEPARATION FROM BUILDING (FEET)*
1Ø	75 OR LESS	5
	100 TO 250	10
3Ø	75 TO 500	15
	750 TO 3000	25

*All measurements are made from the edge of the transformer pad closest to the building in question.

Exceptions for 1Ø transformers 75 KVA or smaller

The transformer pad may be placed between 5 and 3 feet from a building wall if:

1. The building wall is constructed of less-flammable construction materials such as metal, masonry, or concrete
2. All window openings in the first story within a horizontal distance of 10 feet of the transformer pad are closed using brick or block
3. All window openings in the first story beyond 10 feet and up to 25 feet horizontally from the transformer pad must utilize wired glass & steel sash or glass block or brick or block
4. All window openings in the second and third stories directly above the transformer must utilize wired glass & steel sash or glass block or brick or block

Exceptions for 3Ø transformers

The transformer pad may be placed closer to the building when utilizing a concrete or masonry firewall barrier with wing walls. The firewall barrier should be placed as far as possible from the building and shall not be placed closer than 5 feet from the building (measured from the building to the closest surface of the firewall barrier). The firewall barrier must satisfy the following criteria:

1. The wing walls shall be the same height as the firewall barrier and constructed from the same material. The wing walls shall extend 3 feet beyond the transformer pad.
2. Pre-existing buildings or block walls may not be used as part of the firewall enclosure. Exceptions may be granted on a case-by-case basis by LG&E and KU.
3. At multi-story buildings, a fire resistive roof shall be added to the firewall enclosure.
4. To lessen fire intensity and to confine the oil, should a leak occur
 - Install transformer on a LG&E and KU approved pad
 - Form a basin around the transformer pad, extending to the firewall enclosure walls and front-side sill, filled with rock, and sized to hold the total contents of the transformer.
 - The basin should be drained to a low isolated ground area, drywell, or other safe location.

SEE PAGES 2 AND 3 FOR CONSTRUCTION DETAILS

LG&E SERVICE AREA - ALL 3Ø TRANSFORMERS
TYPICAL WINGWALL CONSTRUCTION BY CUSTOMER FOR A PADMOUNT
TRANSFORMER WITH LESS THAN 8 SETS OF SECONDARIES.

NOTE:

1. THE DRAWINGS BELOW DETAIL THE TYPICAL CONSTRUCTION OF A FIRE WALL AROUND A PADMOUNT TRANSFORMER. THE ACTUAL STRUCTURAL DESIGN IS THE RESPONSIBILITY OF THE CUSTOMER. THESE DRAWINGS ASSUME THE FRONT OF THE TRANSFORMER FACES THE OPENING. FOR DIFFERENT CONFIGURATIONS OR FOR DETAILED INFORMATION ABOUT A SPECIFIC INSTALLATION, CONSULT THE JOB CONSTRUCTION PRINTS.
2. PAD REINFORCEMENT DESIGNED BY CUSTOMER, TO SUPPORT A TOTAL WEIGHT OF 17,000 LBS. FOR DETAILS ON PAD CONSTRUCTION, SEE STANDARD #42 06 03.
3. BEFORE INSTALLING PAD NOTIFY - DESIGN TECHNICIAN / LOCATOR FOR INSPECTION OF PAD FORMING, PLACEMENT OF DUCT ELLS, GROUND WIRE AND GROUND RODS. A MINIMUM OF 24 HOURS IS REQUIRED.
4. PROTECTIVE PIPE MAY BE REQUIRED. SEE DRAWING #04 10 04 FOR DETERMINATION OF PROTECTION TO BE MADE AFTER CURB AND DRIVING LANES ARE INSTALLED.
5. 3'- 0" MINIMUM INSIDE CLEARANCE ON ALL SIDES (MEASURED FROM EDGE OF TRANSFORMER PAD).
6. THE ELEVATION OF THE EQUIPMENT PAD SHOULD BE 1" ABOVE THE ELEVATION OF THE SILL OR 10" ABOVE GRADE.
7. DESIGN AND PLACEMENT OF WINGWALL CONSTRUCTION MUST BE APPROVED BY LG&E/KU.

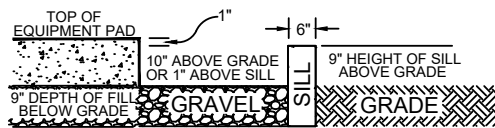

TYPICAL CONTAINMENT BASIN
TOP VIEW

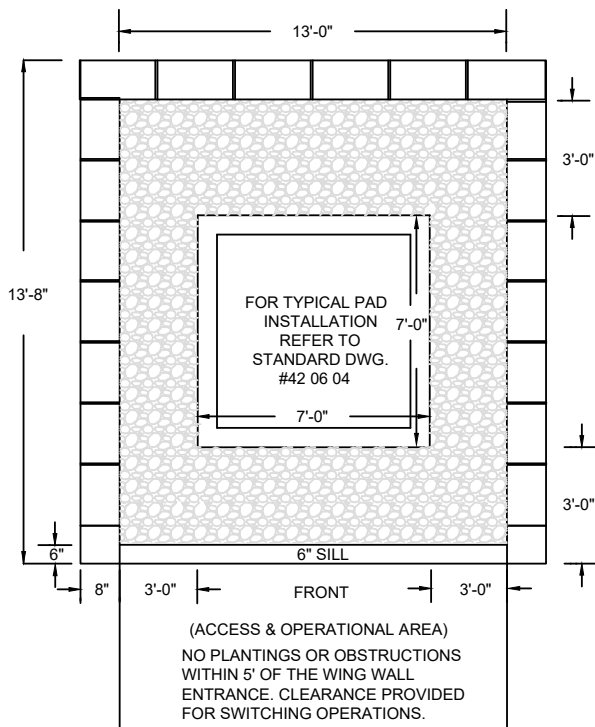

(ACCESS & OPERATIONAL AREA)
NO PLANTINGS OR OBSTRUCTIONS
WITHIN 5' OF THE WING WALL
ENTRANCE. CLEARANCE PROVIDED
FOR SWITCHING OPERATIONS.

TYPICAL
ROOF PANEL DETAIL (WHEN REQUIRED)

ALL DIMENSIONS ARE OFF EDGE OF PAD

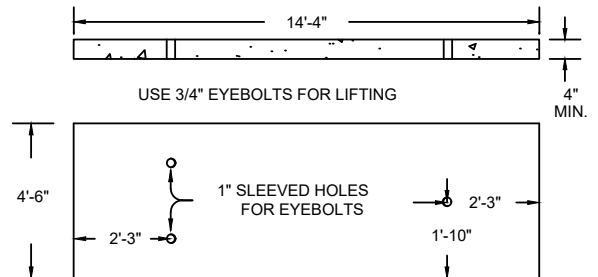

SLAB REINFORCED WITH NO.4 REBAR-12 O.C.

TOP SUPPORT COVER TO BE DESIGNED BY CUSTOMER AND BE A MIN. OF 4" THICK AND LONG ENOUGH TO COVER WINGWALLS. COVER TO BE 3 SEPARATE SECTIONS WITH 3 LIFTING LUG HOLES PER SECTION FOR EASY REMOVAL. SLABS TO BE MADE OF CONCRETE AND BE SELF SUPPORTING.

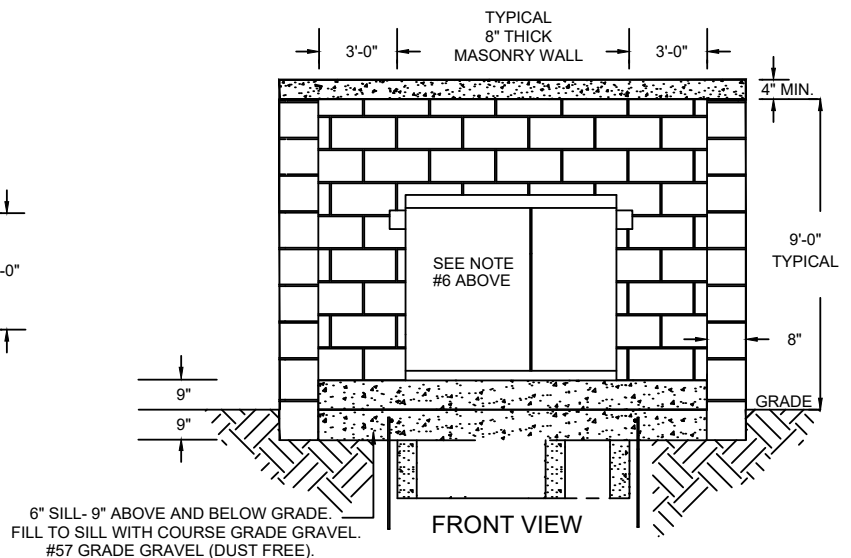

6" SILL- 9" ABOVE AND BELOW GRADE.
FILL TO SILL WITH COURSE GRADE GRAVEL.
#57 GRADE GRAVEL (DUST FREE).

KU SERVICE AREA - 3Ø 500KVA TRANSFORMERS AND SMALLER
TYPICAL WINGWALL CONSTRUCTION BY CUSTOMER FOR A PADMOUNT
TRANSFORMER WITH LESS THAN 8 SETS OF SECONDARIES.

NOTE:

1. THE DRAWINGS BELOW DETAIL THE TYPICAL CONSTRUCTION OF A FIRE WALL AROUND A PADMOUNT TRANSFORMER. THE ACTUAL STRUCTURAL DESIGN IS THE RESPONSIBILITY OF THE CUSTOMER. THESE DRAWINGS ASSUME THE FRONT OF THE TRANSFORMER FACES THE OPENING. FOR DIFFERENT CONFIGURATIONS OR FOR DETAILED INFORMATION ABOUT A SPECIFIC INSTALLATION, CONSULT THE JOB CONSTRUCTION PRINTS.
2. PAD REINFORCEMENT DESIGNED BY CUSTOMER, TO SUPPORT A TOTAL WEIGHT OF 17,000 LBS. FOR DETAILS ON PAD CONSTRUCTION, SEE STANDARD #42 06 03.
3. BEFORE INSTALLING PAD NOTIFY - DESIGN TECHNICIAN / LOCATOR FOR INSPECTION OF PAD FORMING, PLACEMENT OF DUCT ELLS, GROUND WIRE AND GROUND RODS. A MINIMUM OF 24 HOURS IS REQUIRED.
4. PROTECTIVE PIPE MAY BE REQUIRED. SEE DRAWING #04 10 04 FOR DETERMINATION OF PROTECTION TO BE MADE AFTER CURB AND DRIVING LANES ARE INSTALLED.
5. 3'- 0" MINIMUM INSIDE CLEARANCE ON ALL SIDES (MEASURED FROM EDGE OF TRANSFORMER PAD).
6. THE ELEVATION OF THE EQUIPMENT PAD SHOULD BE 1" ABOVE THE ELEVATION OF THE SILL OR 10" ABOVE GRADE.
7. DESIGN AND PLACEMENT OF WINGWALL CONSTRUCTION MUST BE APPROVED BY LG&E/KU.

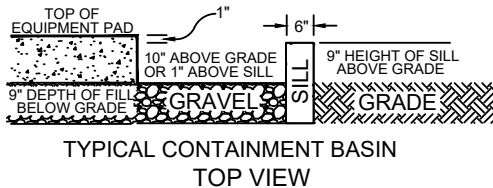

TYPICAL ROOF PANEL DETAIL (WHEN REQUIRED)

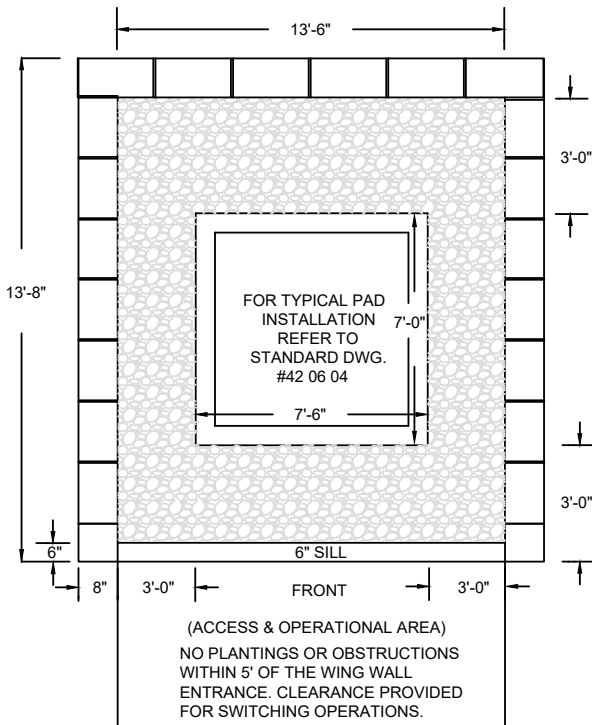
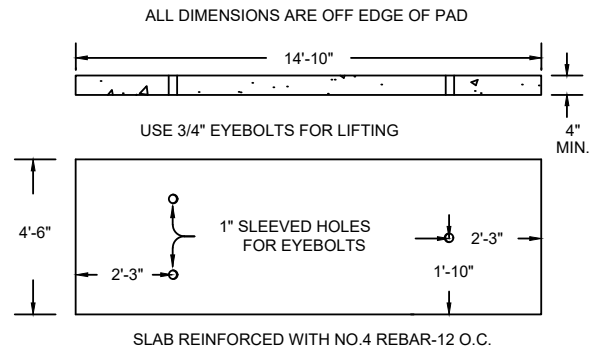

TOP SUPPORT COVER TO BE DESIGNED BY CUSTOMER AND BE A MIN. OF 4" THICK AND LONG ENOUGH TO COVER WINGWALLS. COVER TO BE 3 SEPARATE SECTIONS WITH 3 LIFTING LUG HOLES PER SECTION FOR EASY REMOVAL. SLABS TO BE MADE OF CONCRETE AND BE SELF SUPPORTING.

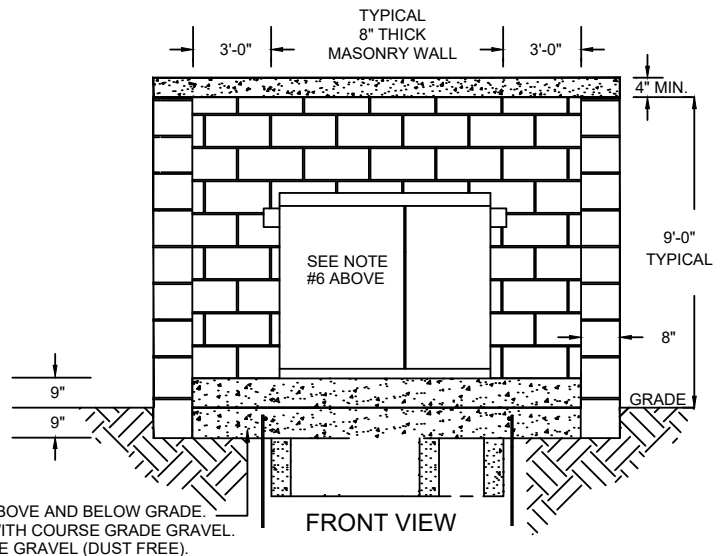

KU SERVICE AREA - 3Ø TRANSFORMERS LARGER THAN 500KVA
TYPICAL WINGWALL CONSTRUCTION BY CUSTOMER FOR A PADMOUNT
TRANSFORMER WITH LESS THAN 8 SETS OF SECONDARIES.

NOTE:

1. THE DRAWINGS BELOW DETAIL THE TYPICAL CONSTRUCTION OF A FIRE WALL AROUND A PADMOUNT TRANSFORMER. THE ACTUAL STRUCTURAL DESIGN IS THE RESPONSIBILITY OF THE CUSTOMER. THESE DRAWINGS ASSUME THE FRONT OF THE TRANSFORMER FACES THE OPENING. FOR DIFFERENT CONFIGURATIONS OR FOR DETAILED INFORMATION ABOUT A SPECIFIC INSTALLATION, CONSULT THE JOB CONSTRUCTION PRINTS.
2. PAD REINFORCEMENT DESIGNED BY CUSTOMER, TO SUPPORT A TOTAL WEIGHT OF 17,000 LBS. FOR DETAILS ON PAD CONSTRUCTION, SEE STANDARD #42 06 03.
3. BEFORE INSTALLING PAD NOTIFY - DESIGN TECHNICIAN / LOCATOR FOR INSPECTION OF PAD FORMING, PLACEMENT OF DUCT ELLS, GROUND WIRE AND GROUND RODS. A MINIMUM OF 24 HOURS IS REQUIRED.
4. PROTECTIVE PIPE MAY BE REQUIRED. SEE DRAWING #04 10 04 FOR DETERMINATION OF PROTECTION TO BE MADE AFTER CURB AND DRIVING LANES ARE INSTALLED.
5. 3'- 0" MINIMUM INSIDE CLEARANCE ON ALL SIDES (MEASURED FROM EDGE OF TRANSFORMER PAD).
6. THE ELEVATION OF THE EQUIPMENT PAD SHOULD BE 1" ABOVE THE ELEVATION OF THE SILL OR 10" ABOVE GRADE.
7. DESIGN AND PLACEMENT OF WINGWALL CONSTRUCTION MUST BE APPROVED BY LG&E/KU.

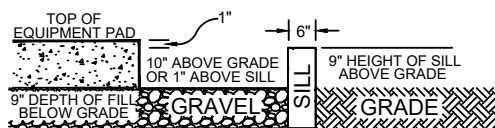

TYPICAL CONTAINMENT BASIN
TOP VIEW

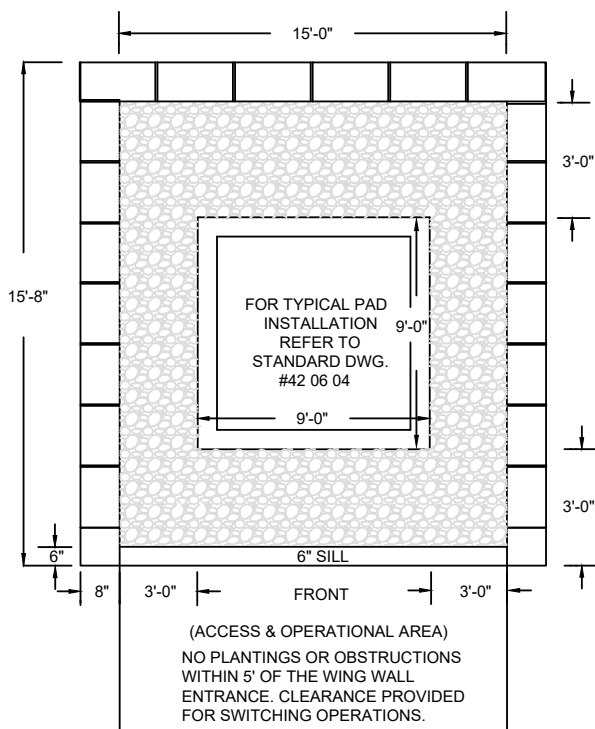

(ACCESS & OPERATIONAL AREA)
NO PLANTINGS OR OBSTRUCTIONS
WITHIN 5' OF THE WING WALL
ENTRANCE. CLEARANCE PROVIDED
FOR SWITCHING OPERATIONS.

TYPICAL
ROOF PANEL DETAIL (WHEN REQUIRED)

ALL DIMENSIONS ARE OFF EDGE OF PAD

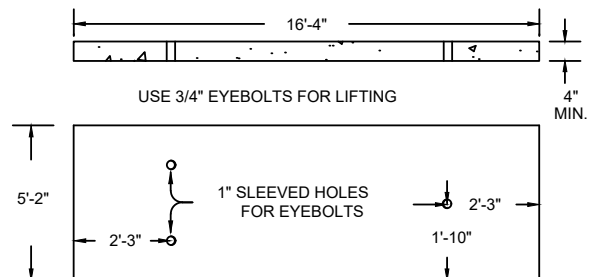

SLAB REINFORCED WITH NO.4 REBAR-12 O.C.

TOP SUPPORT COVER TO BE DESIGNED BY CUSTOMER AND BE A MIN. OF 4" THICK AND LONG ENOUGH TO COVER WINGWALLS. COVER TO BE 3 SEPARATE SECTIONS WITH 3 LIFTING LUG HOLES PER SECTION FOR EASY REMOVAL. SLABS TO BE MADE OF CONCRETE AND BE SELF SUPPORTING.

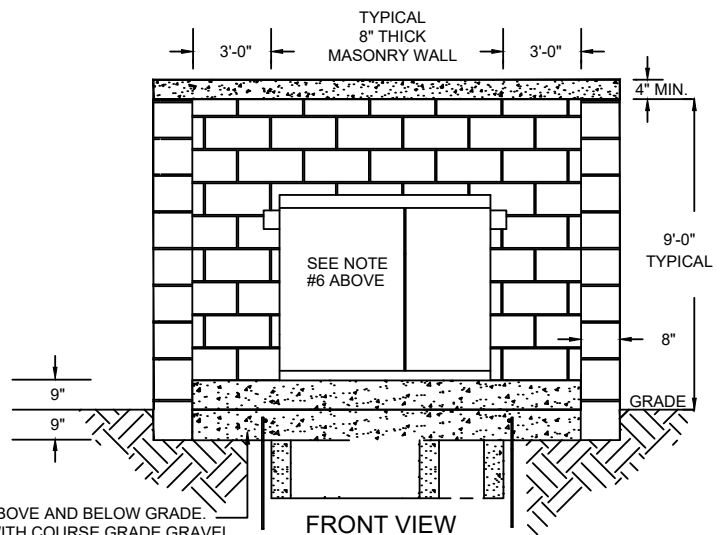

6" SILL- 9" ABOVE AND BELOW GRADE.
FILL TO SILL WITH COURSE GRADE GRAVEL.
#57 GRADE GRAVEL (DUST FREE).

TYPICAL WINGWALL CONSTRUCTION BY CUSTOMER FOR A PADMOUNT TRANSFORMER WITH MORE THAN 8 SETS OF SECONDARIES.

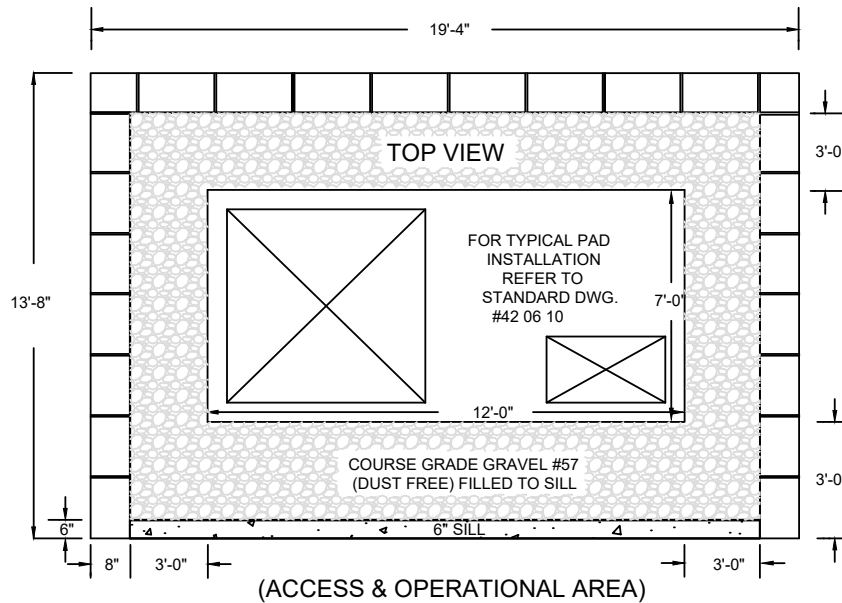

NO PLANTINGS OR OBSTRUCTIONS WITHIN 5' OF THE WING WALL ENTRANCE. CLEARANCE PROVIDED FOR SWITCHING OPERATIONS.

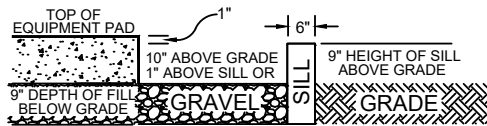

TYPICAL CONTAINMENT BASIN

TOP SUPPORT COVER TO BE DESIGNED BY CUSTOMER AND BE LONG ENOUGH TO COVER WINGWALLS. COVER TO BE 3 SEPERATE SECTIONS WITH 3 LIFTING LUG HOLES PER SECTION FOR EASY REMOVAL. SLABS TO BE MADE OF CONCRETE AND BE SELF SUPPORTING. COMPOSITION AND STRENGTH TO BE DETERMINED BY OWNER'S ENGINEER OR ARCHITECT.

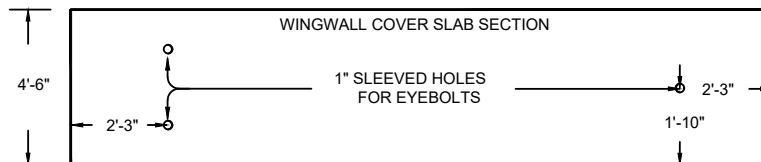

TYPICAL ROOF PANEL DETAIL (WHEN REQUIRED)

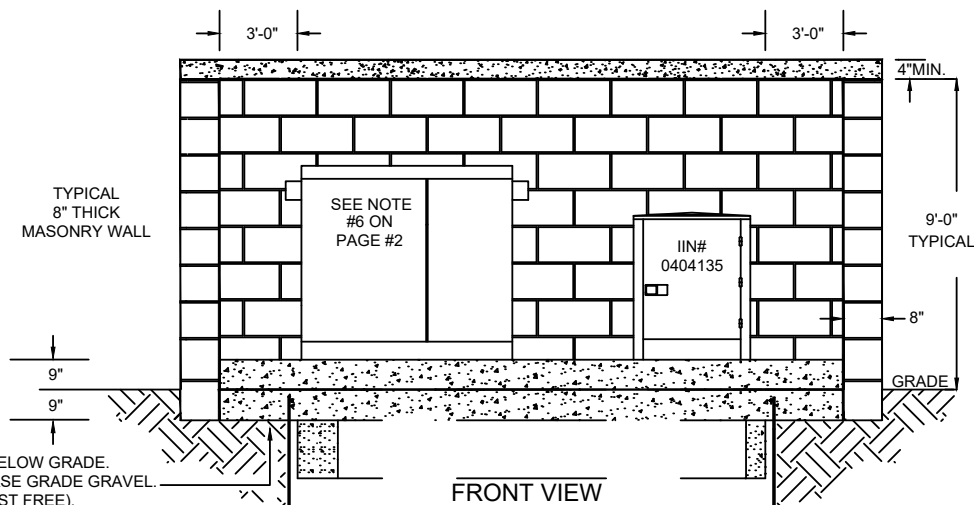

NOTE:

- PAD REINFORCEMENT DESIGNED BY CUSTOMER, TO SUPPORT A TOTAL WEIGHT OF 2,500 LBS.
- BEFORE INSTALLING PAD NOTIFY LG&E/KU FOR INSPECTION OF SITE, AND PLACEMENT OF DUCT ELLS, GROUND WIRE AND GROUND RODS. A MINIMUM OF ONE WORKING DAY NOTICE IS REQUIRED. LG&E SERVICE AREAS MUST USE A PRECAST PAD, A POURED PAD IS NOT ACCEPTABLE.
- DIRECTION OF DUCT DETERMINED BY LAYOUT FOR CUSTOMER INSTALLED PAD.
- PROTECTIVE PIPE MAY BE REQUIRED. SEE STANDARD 04 10 04
- DUCT SIZE AND DIRECTION TO BE SPECIFIED BY UTILITY

PRECAST CONCRETE PAD

IN	DESCRIPTION	STYLE
3007597	PAD, SWITCHGEAR, CONCRETE	6, 9, 10, 11, AND 12

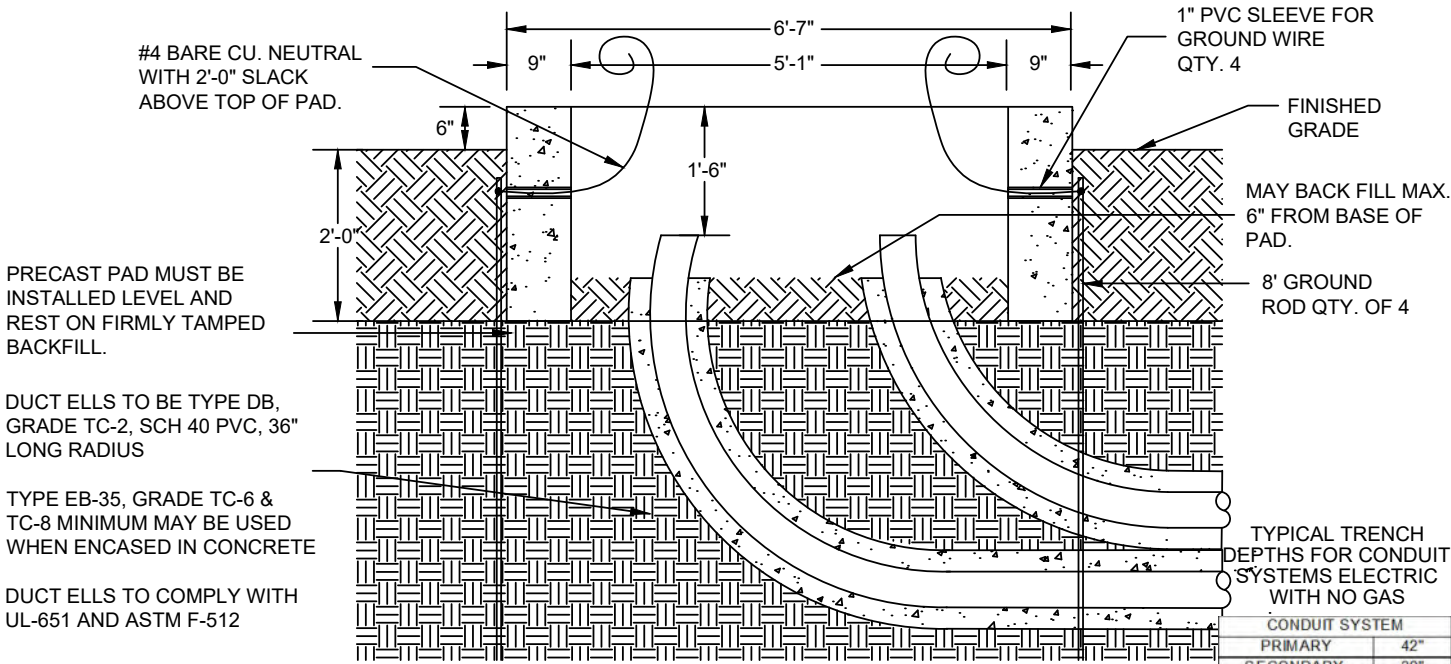
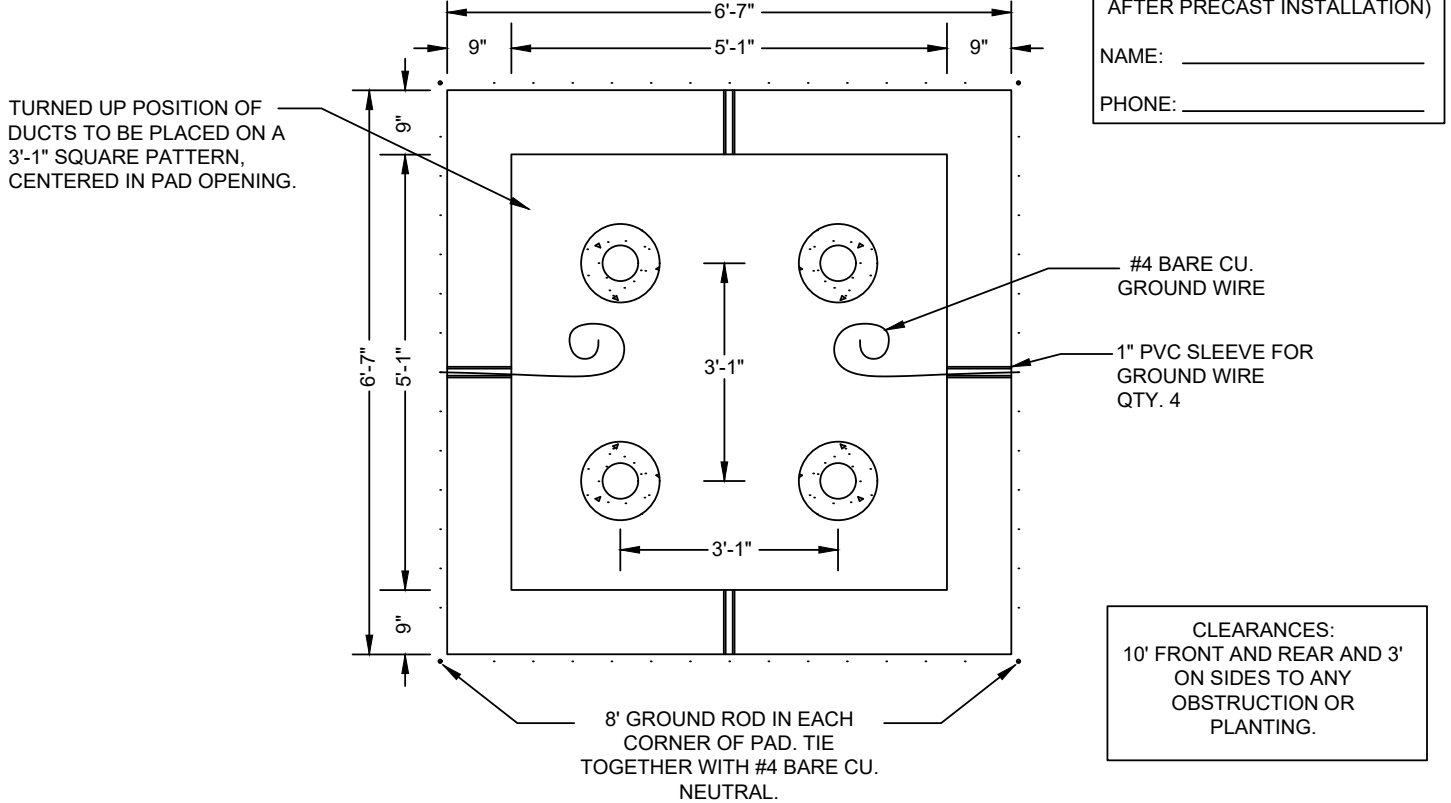

NOTE:

1. SEE STANDARD 42 06 26 FOR FIBERGLASS BOX PAD INSTALLATION DETAILS.
2. SEE STANDARD 42 06 22 FOR POURED AND PRECAST CONCRETE PAD INSTALLATION DETAILS.

TYPICAL DEADFRONT SWITCHGEAR PADS

IIN	DESCRIPTION	STYLE
3003549	PAD, SWITCHGEAR, FIBERGLASS	5
3003550	PAD, SWITCHGEAR, FIBERGLASS	6, 9, 10, 11, AND 12
3007597	PAD, SWITCHGEAR, CONCRETE	6, 9, 10, 11, AND 12

IIN# 3007597 - PRECAST CONCRETE PAD

69" x 69" x 30" DEADFRONT SWITCHGEAR PRECAST CONCRETE PAD WITH 61" x 61" OPENING.

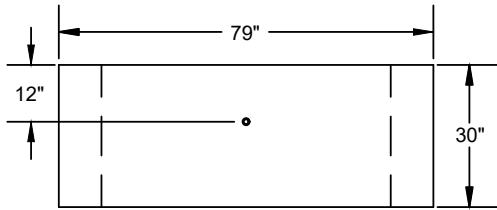

SIDE VIEW

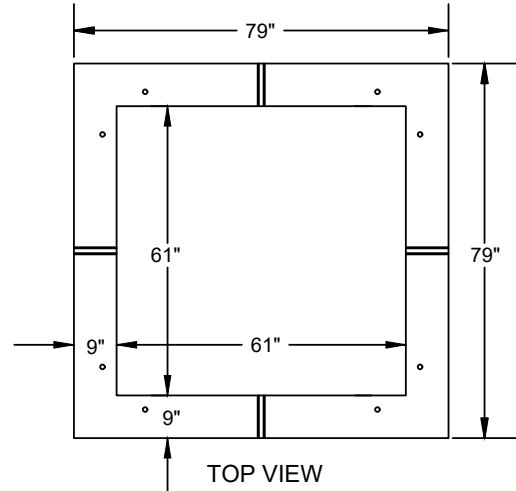

TOP VIEW

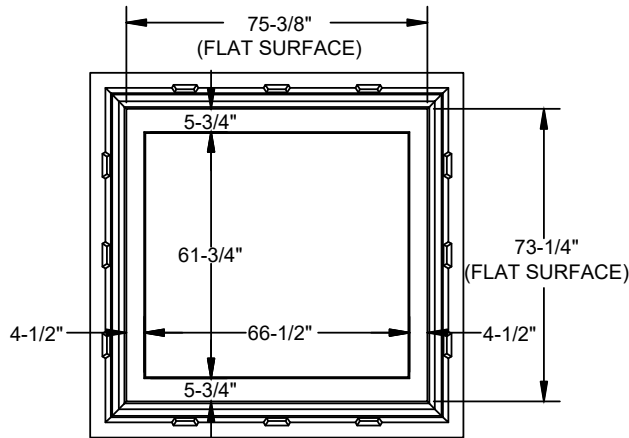

TOP VIEW

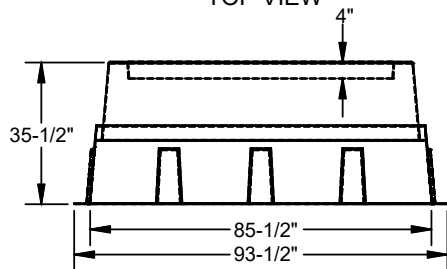

DOOR SIDE VIEW

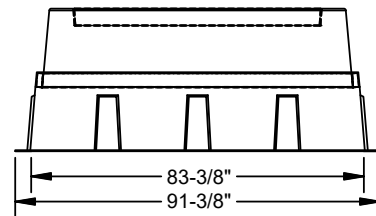

CABINET VIEW

IIN# 3003550 - FIBERGLASS PAD

75-3/8" x 73-1/4" x 35-1/2" DEADFRONT SWITCHGEAR FIBERGLASS PAD WITH 61-3/4" x 66-1/2" OPENING.

IIN# 3003549 - FIBERGLASS PAD

74" x 44-1/2" x 36" DEADFRONT SWITCHGEAR
FIBERGLASS PAD WITH 61" x 31-1/2" OPENING.

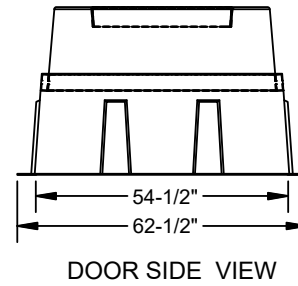
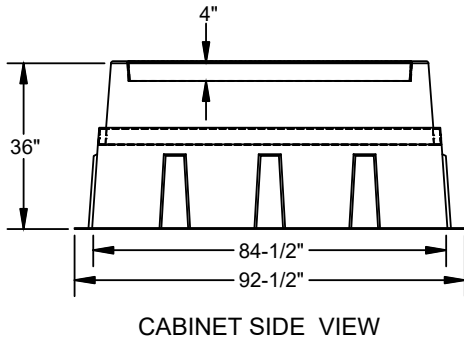
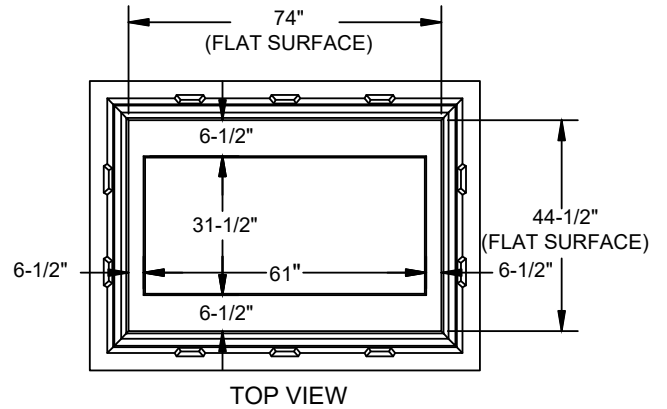

DEAD-FRONT DESIGN			
LG&E AND KU ITEM#	SWITCH BAY	FUSE BAY	DESCRIPTION
3003548	1	1	PADMOUNT, DEADFRONT STYLE #5, MANUAL, 15KV 600 AMP, 3 PHASE, 2 COMP, 1-600A GANG SWITCH AND 1-200A FUSED WITH SMU20 HOLDERS, 12" BASE EXT
7010725	2	1	PADMOUNT, DEADFRONT STYLE #6, MANUAL, 15KV 600 AMP, 3 PHASE, 4 COMP, 2-600A GANG SWITCH AND 1-200A FUSED WITH SMU20 HOLDERS, 12" BASE EXT
7010014	2	2	PADMOUNTED, DEADFRONT STLYE #9, MANUAL, 15KV 600 AMP, 3 PHASE, 4 COMP, 2-600A GANG SWITCH AND 2-200A FUSED WITH SMU20 HOLDERS, 12" BASE EXT
3007336	4	0	PADMOUNT, DEADFRONT STYLE #10, MANUAL, 15KV, 600A, 3PH, 4 COMP, 4-600A GANG SWITCH, 12" BASE TEXT
3007337	3	1	PADMOUNT, DEADFRONT STYLE #11, MANUAL, 15KV, 600A, 3PH, 4 COMP, 3-600A GANG SWITCH AND 1-200A FUSED WITH SMU20 HOLDERS, 12" BASE EXT
3007338	1	3	PADMOUNT, DEADFRONT STYLE #12, MANUAL, 15KV, 600A, 3PH, 4 COMP, 1-600A GANG SWITCH AND 3-200A FUSED WITH SMU20 HOLDERS, 12" BASE TEXT

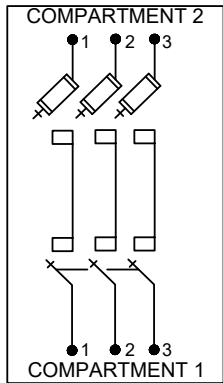

STYLE-5

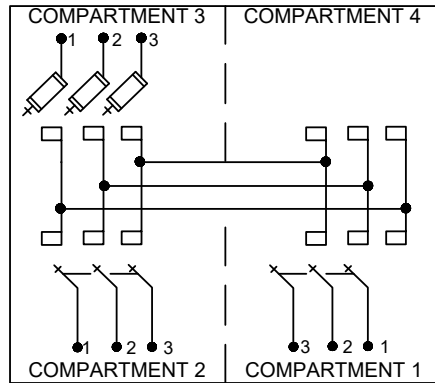

STYLE-6

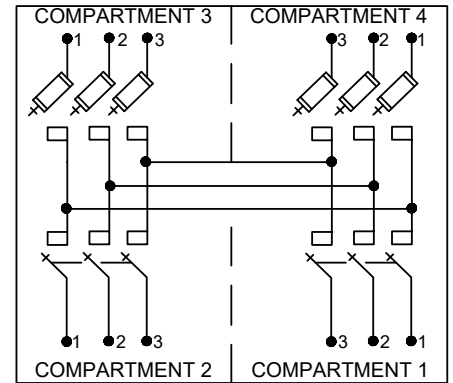

STYLE-9

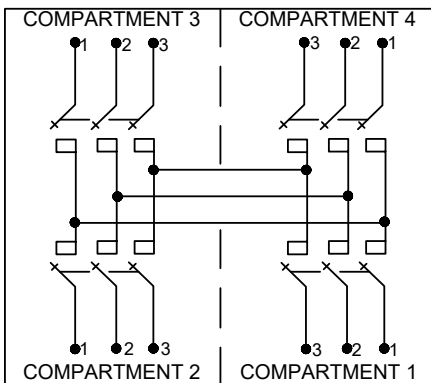

STYLE-10

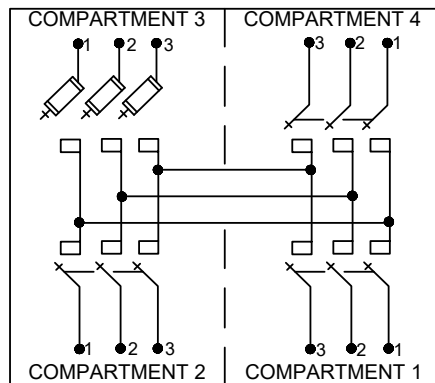

STYLE-11

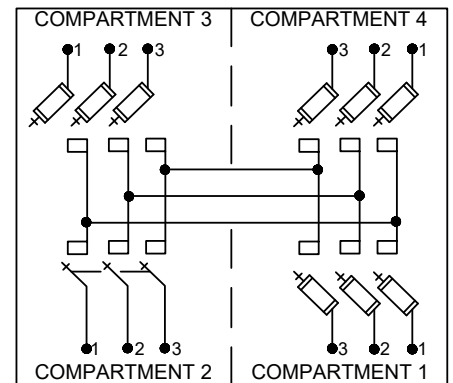

STYLE-12

1 PHASE PARALLEL SECONDARY

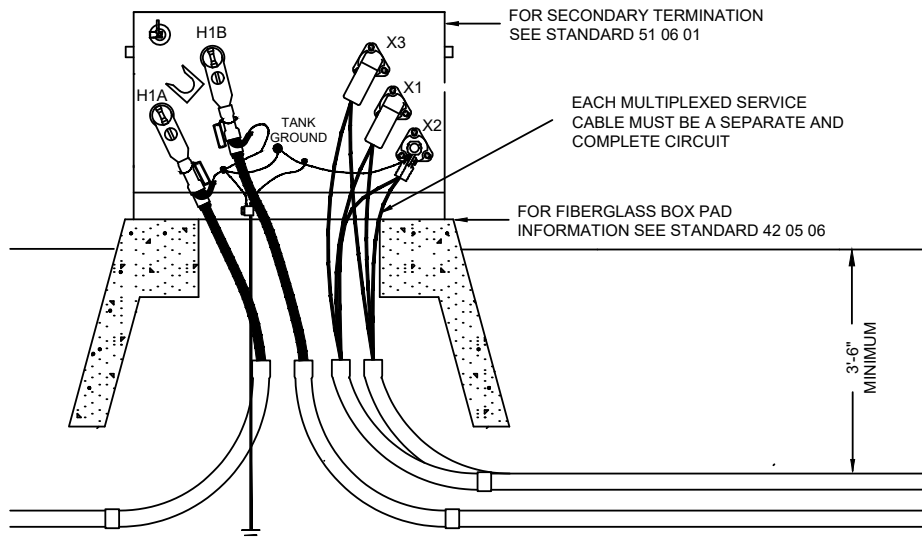

3 PHASE PARALLEL SECONDARY

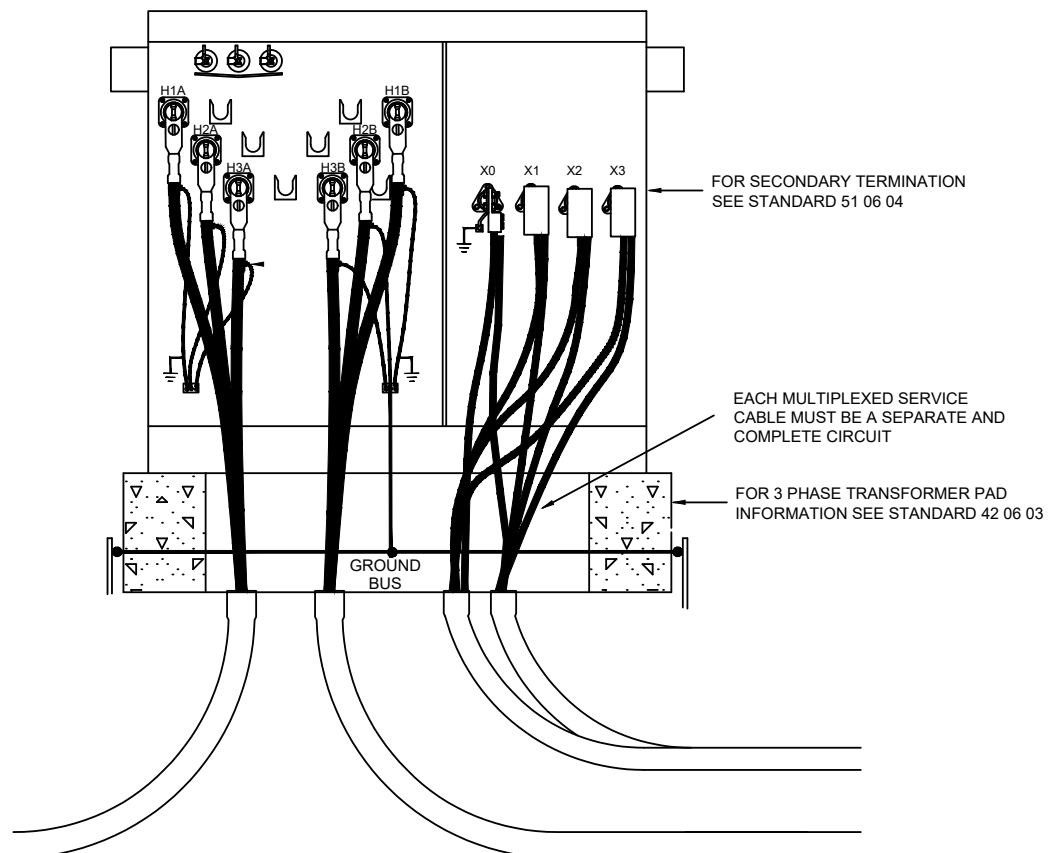

NOTES:

1. MAX OF TWO ELBOWS UNLESS PRE-APPROVED BY THE UTILITY.
2. FOR NEW CONSTRUCTION, CONDUIT STRAPS TO BE ANCHORED WITH THROUGH THE WALL FASTENERS. FOR OVERHEAD TO UNDERGROUND CONVERSIONS, USE UNISTRUT, MINIMUM 3/8" LAG BOLTS, AND HEAVY DUTY UNISTRAP CLAMP.
3. SCHEDULE 40 TO SCHEDULE 80 TRANSITION SHALL OCCUR BELOW GRADE.
4. THE USE OF A SLIP COUPLING IS RECOMMENDED TO COMPENSATE FOR THERMAL EXPANSION AND CONTRACTION OF THE PVC DUCT. WHEN A SLIP COUPLING IS USED, CONDUIT STRAP SHOULD BE PLACED ABOVE THE SLIP COUPLING.

MATERIAL LIST

ITEM	IIN	DESCRIPTION	QTY
1	7001180	CLAMP, CONDUIT, 2-1/2" TO 3-1/2", GROUNDING, BRONZE	1
2	7002218	CONDUCTOR, OH WIRE, 4, CU-SD/BARE, SOLID	AR
3	7000887	CLAMP, GROUND ROD, 5/8", 8-1/0, HEX, CU, HEAVY DUTY	1
4	7000888	ROD, GROUND, 5/8" X 8', BONDED COPPER	1

AR - AS REQUIRED

TYPICAL KU/ODP SECONDARY RISER POLE INSTALLATION

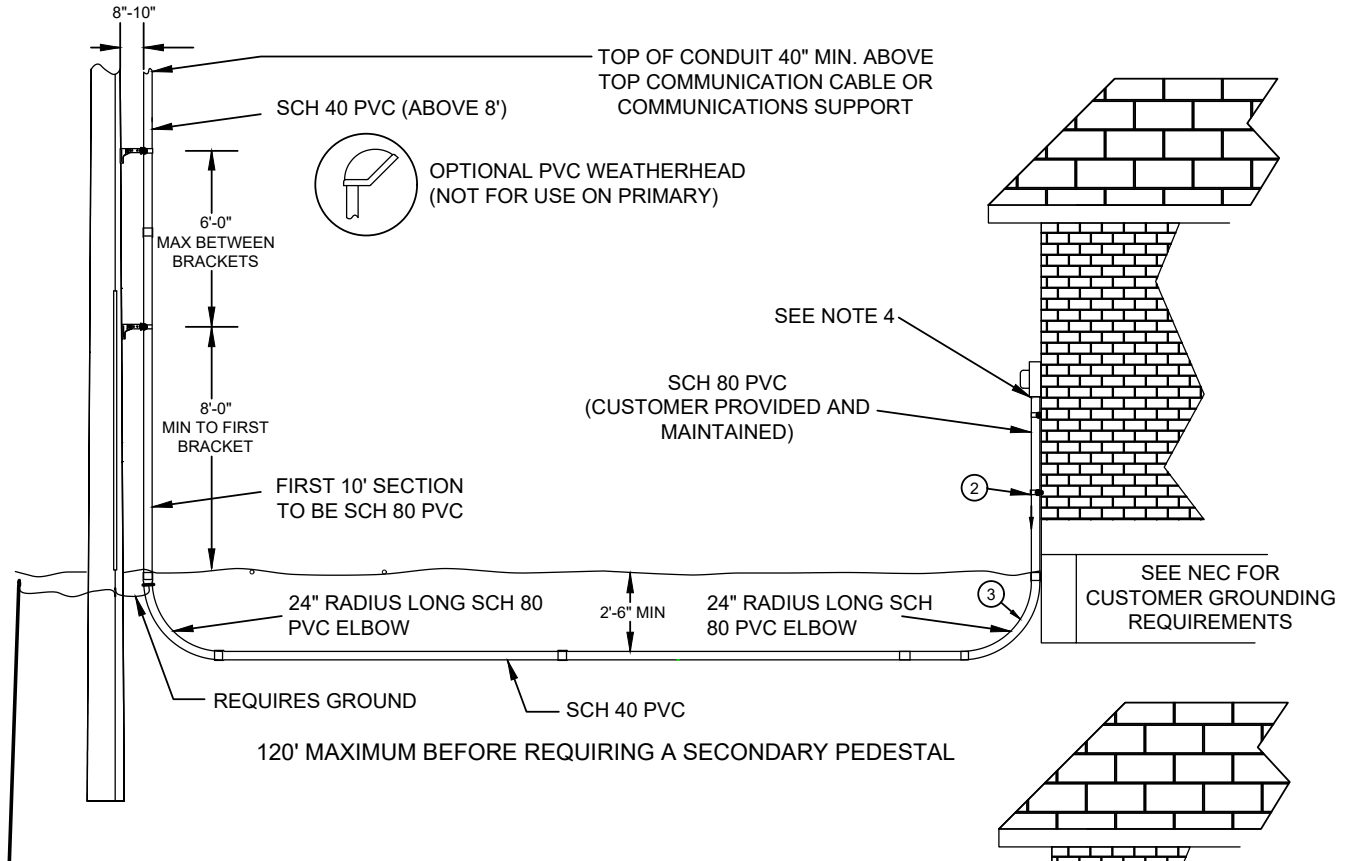

IIN #	DESCRIPTION	SERVICE	MINIMUM CONDUIT SIZE
7001428	TWO 2/0 AL PHASE CONDUCTORS AND ONE #1 NEUTRAL	100 AND 200 AMPS	3"
7001429	TWO 4/0 AL PHASE CONDUCTORS AND ONE 2/0 NEUTRAL	300 AMPS	3"
7003425	TWO 350 AL PHASE CONDUCTORS AND ONE 4/0 NEUTRAL	400 AMPS	3"

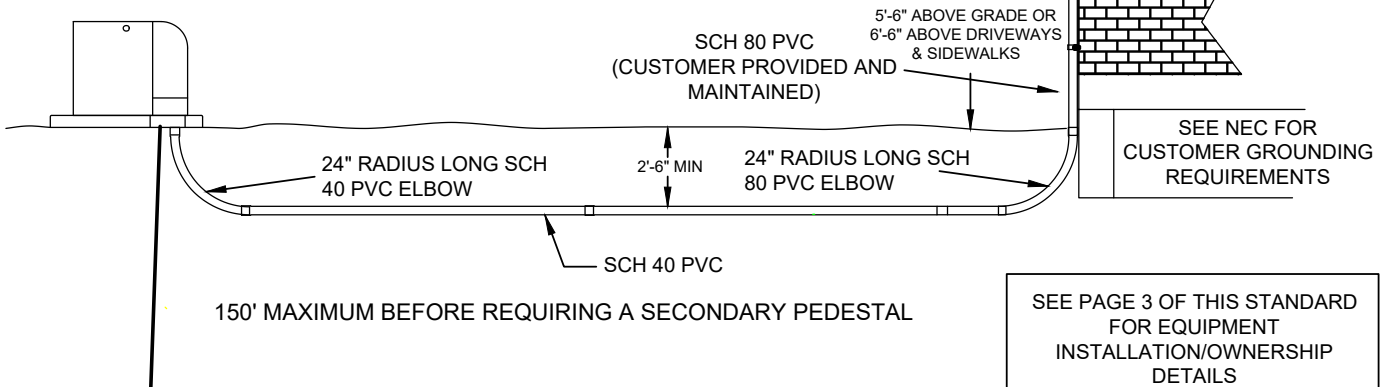

NOTES:

1. SPLICE BOX TO BE SET IN EASEMENT ON CUSTOMER'S PROPERTY, AS CLOSE TO BASE OF POLE AS POSSIBLE, BUT NO CLOSER THAN 6".
2. THE USE OF A SLIP COUPLING IS RECOMMENDED TO COMPENSATE FOR THERMAL EXPANSION AND CONTRACTION OF THE PVC DUCT. WHEN A SLIP COUPLING IS USED, CONDUIT STRAP SHOULD BE PLACED ABOVE THE SLIP COUPLING.

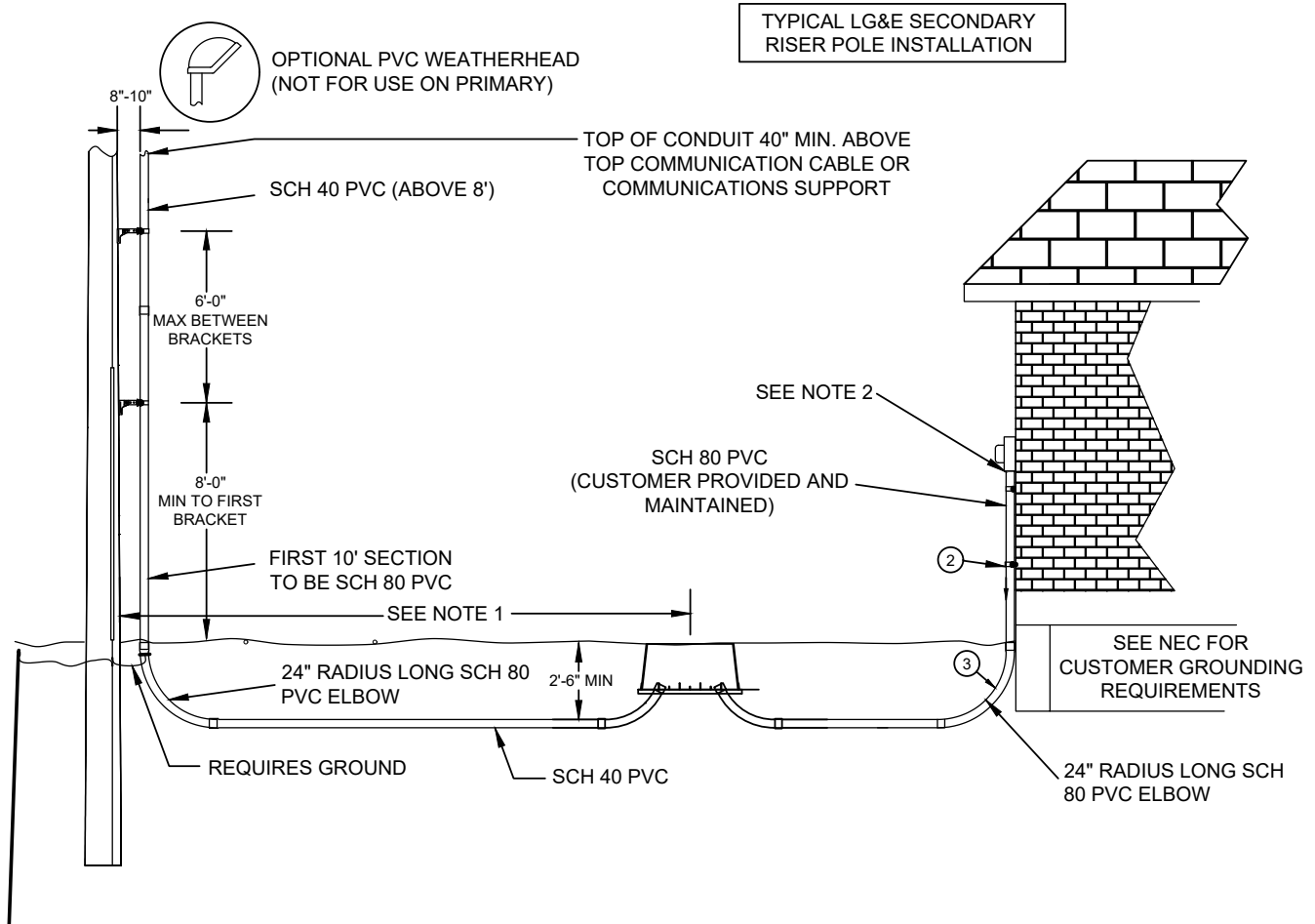

KU/ODP INSTALLATIONS

CUSTOMER-OWNED AND INSTALLED
(ALL EQUIPMENT INSTALLED TO KU/ODP SPECIFICATIONS)

- METER BASE, METER ENCLOSURES AND DISCONNECT
- GROUND CONDUCTORS, RODS, ETC.
- CONDUIT FROM METER BASE TO TRANSFORMER/PEDESTAL STUB OUT

KU/ODP-OWNED AND INSTALLED EQUIPMENT

- TRANSFORMER AND/OR PEDESTAL
- UTILITY SERVICE LINES TO THE CUSTOMER'S POINT OF OWNERSHIP
- METER AND METERING TRANSFORMERS, IF APPLICABLE

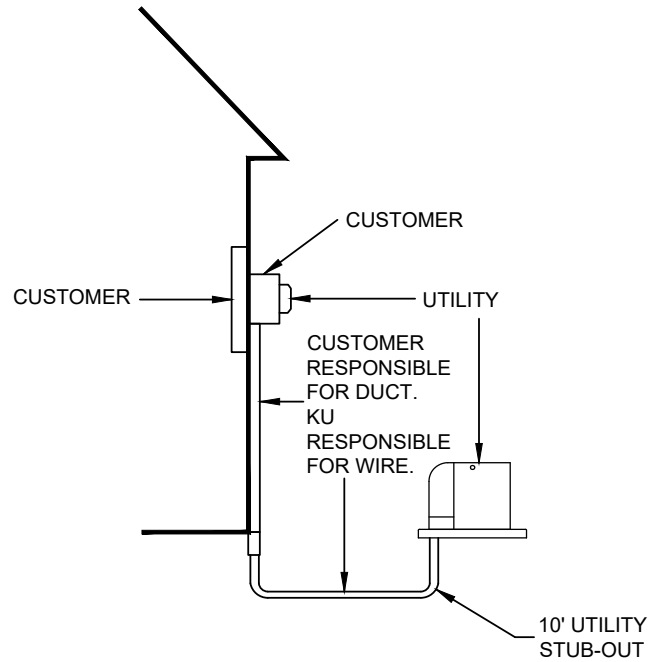

LG&E INSTALLATIONS

CUSTOMER-OWNED AND INSTALLED
(ALL EQUIPMENT INSTALLED TO LG&E SPECIFICATIONS)

- SPLICE BOX (OVERHEAD TO UNDERGROUND SERVICE ONLY)
- METER BASE, METER ENCLOSURES AND DISCONNECT
- SERVICE LINES AND CONDUIT TO THE TRANSFORMER OR SPLICE BOX
- GROUND CONDUCTORS, RODS, ETC.

LG&E-OWNED AND INSTALLED EQUIPMENT

- TRANSFORMER AND/OR PEDESTAL
- UTILITY SECONDARY LINES TO THE CUSTOMER'S POINT OF OWNERSHIP
- METER AND METERING TRANSFORMERS, IF APPLICABLE

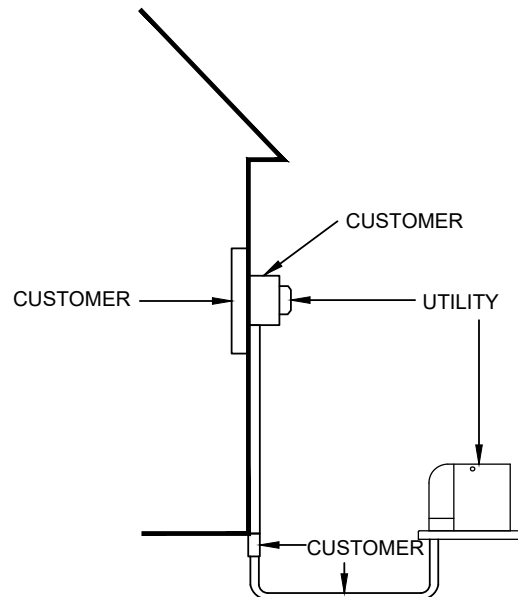

NOTE:

1. COMMERCIAL CUSTOMERS WHO ARE SERVED BY A SINGLE PHASE UNDERGROUND SERVICE TYPICALLY REQUIRE LARGE SECONDARY CONDUCTORS THAT ARE OFTEN RUN IN PARALLEL. THEREFORE, THE SINGLE PHASE PADMOUNT TRANSFORMER SHOULD BE INSTALLED ON A FIBERGLASS BOX PAD TO ALLOW MORE ROOM FOR SECONDARY CONDUCTOR MANAGEMENT.

TYPICAL TRENCH DEPTHS
FOR CONDUIT SYSTEMS
ELECTRIC WITH NO GAS

CONDUIT SYSTEM	
PRIMARY	42"
SECONDARY	30"

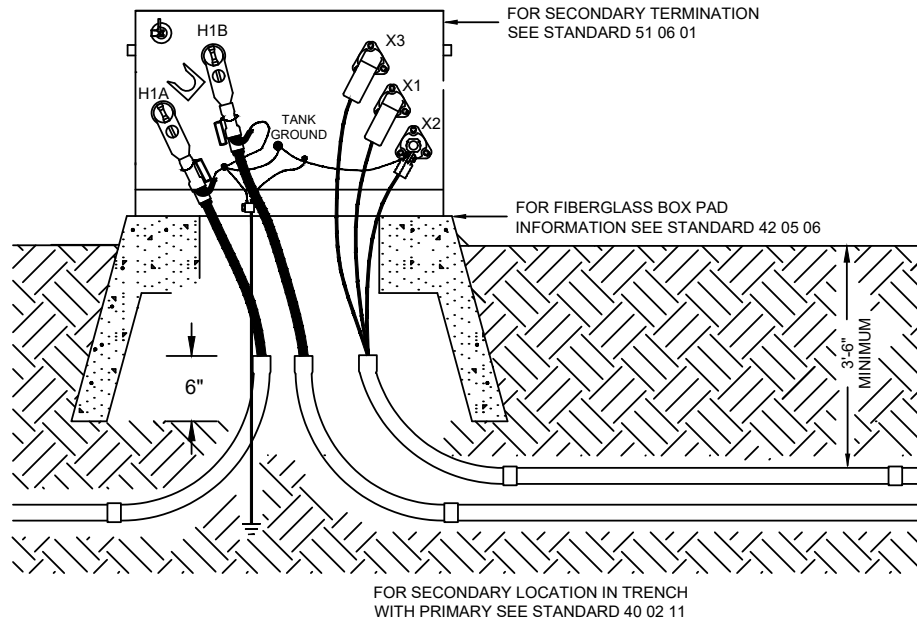

CABINET SPECIFICATIONS

- A - 14 GAUGE GALVANIZED SHEET METAL REINFORCED WHEN NECESSARY.
- B - BAKED GRAY FINISH INSIDE AND OUT.
- C - SIDE HINGED DOUBLE DOORS.
- D - 3 POINT PAD LOCKING HANDLE & LATCH ASSEMBLY.
- E - PROVISIONS IN BACK FOR MOUNTING.
- F - NEMA 1 RATING INDOOR AND NEMA RATING 3R FOR OUTDOOR.
- G - OUTDOOR INSTALLATIONS MUST USE NEMA 3R HUBS IN TOP OF CABINET.
- H - MUST BE UL LISTED.
- I - USE 12" CABINET DEPTH FOR < 800 AMP SERVICE.
- J - USE 14" CABINET DEPTH FOR 800 AMP TO 1900 AMP SERVICES.
- K - THE C.T. ENCLOSURE SHALL NOT BE USED AS AN AUXILIARY GUTTER OR JUNCTION BOX.
- L - USE 1.5" SCH 80 OR RIGID STEEL CONDUIT TO KWH METER. (KU)
- M - USE 1" RIGID STEEL CONDUIT TO KWH METER. (LGE)

METER BASE TO BE
GROUNDED TO
SYSTEM GROUND
WITH MINIMUM #6
COPPER

SPECIFIC CABINET SIZE

1. MINIMUM C.T. ENCLOSURE SIZE FOR 3Ø SERVICE
 - 1.1. MINIMUM CABINET SIZE 48"X48"X14"
 - 1.2. INSULATING BOARD - 3/4" TREATED PLYWOOD 48" X 48"
2. MINIMUM C.T. ENCLOSURE SIZE FOR 1Ø SERVICE
 - 2.1. SERVICES LESS THAN 1200A MINIMUM CABINET SIZE 36"X36"X12"
 - 2.2. FOR 1200A SERVICES MINIMUM CABINET SIZE 48"X48"X14" IS REQUIRED DUE TO SIZE OF C.T.'S
 - 2.3. INSULATING BOARD - 3/4" TREATED PLYWOOD 34" X 34"

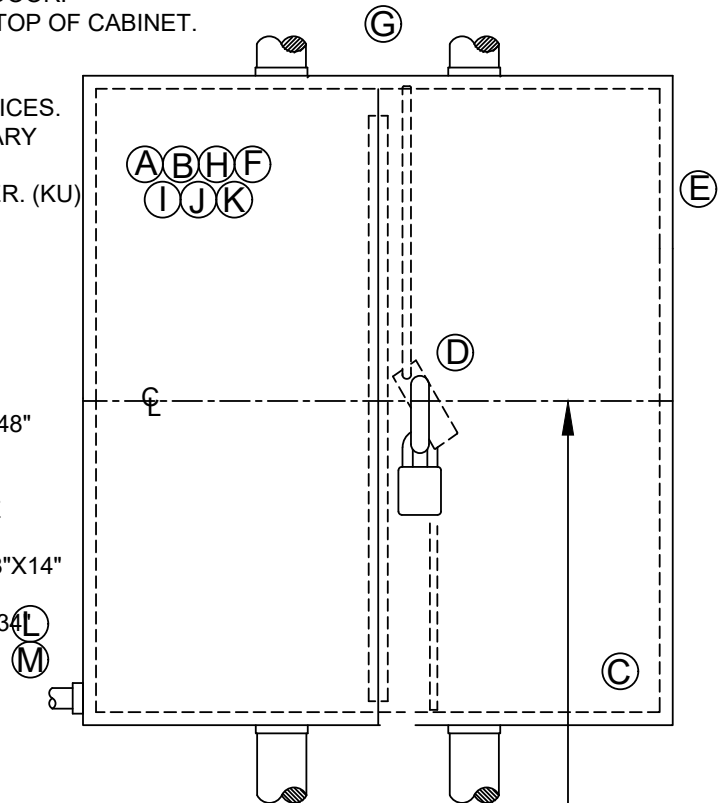

5' 6"
TYPICAL
SEE NOTE 5

CONTRACTORS NOTES

1. EQUIPMENT PROVIDED BY LGE/KU SHALL INCLUDE METER BASES, METERING TRANSFORMERS AND SECONDARY WIRING.
2. CONTRACTOR SHALL PROVIDE AND INSTALL PLYWOOD AND CONDUIT WHERE REQUIRED AT THE LOCATION DESIGNATED BY LG&E/KU SERVICE LOCATOR/DESIGNER OR METER DEPARTMENT SUPERVISORS.
3. CONTRACTOR SHALL INSTALL METERING TRANSFORMERS PROVIDED BY UTILITY.
4. ELECTRICIANS SHALL PROVIDE PULL STRING FROM C.T. CABINET TO METER BASE ON RUNS OVER 10'-0".
5. BOTTOM OF CABINET SHALL BE MINIMUM 12" ABOVE FINISHED GRADE AND TOP OF CABINET SHALL BE MAXIMUM OF 6' ABOVE FINISHED GRADE.

FLOOR LEVEL

NOTE:

- 120/240V 1Ø 3W CONDUCTOR SHALL NOT EXCEED THE LG&E CO. LIMITATIONS FOR SINGLE PHASE SERVICE ENTRANCES: MAX. RESIDENTIAL OVERHEAD = 800A, UNDERGROUND = 1200A
- THE C.T. ENCLOSURE SHALL NOT BE USED AS AN AUXILIARY GUTTER OR JUNCTION BOX.
- DIAGRAM SHOWN FOR OH SERVICE. FOR UG SERVICE, ROTATE INTERNAL LAYOUT 180°.

MINIMUM C.T. ENCLOSURE SIZE USING UP TO 5 CABLES (NOT SHOWN) PER PHASE 120/240V 1Ø 3W >400 - 1200 A

METER BASE TO BE GROUNDED TO SYSTEM GROUND WITH MINIMUM #6 COPPER

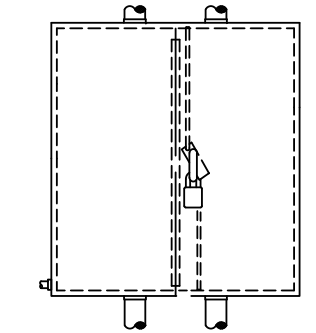
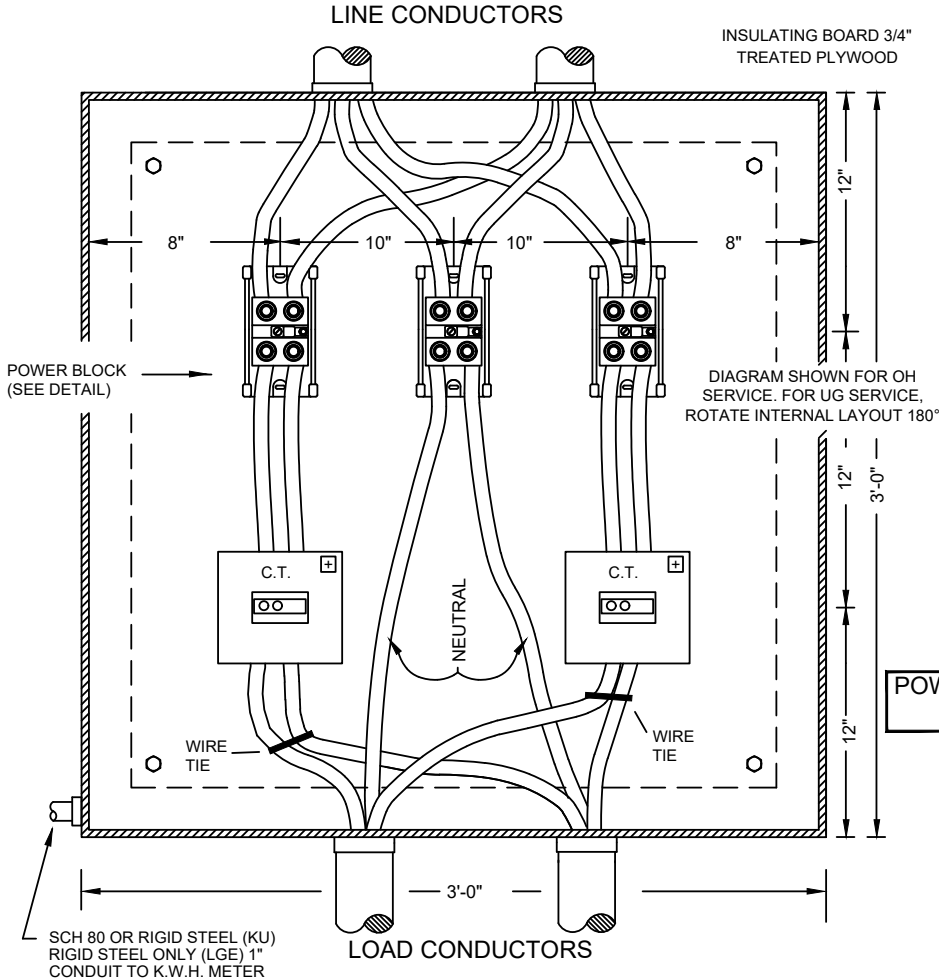

SEE STANDARD 81 10 00 FOR VARIOUS CABINET SIZES AND SPECIFICATIONS.

* IMPORTANT * OUTDOOR INSTALLATIONS MUST USE NEMA 3R HUBS IN TOP OF CABINET

POWER BLOCK DETAIL LUG FOR TAP SCREWED TO TOP OF BLOCK

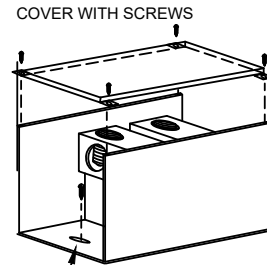

ATTACH BLOCK TO PLYWOOD WITH (2) SCREWS. (1) REAR. (1) FRONT.

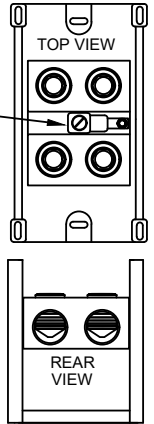

NUMBER OF CONDUCTORS	MAXIMUM CONDUCTOR SIZE	
	COPPER	ALUMINUM
PARALLEL (MAX. OF 2 PER LEG) 800A	500MCM	500MCM
PARALLEL (MAX. OF 5 PER LEG) 1200A	600MCM	600MCM

EQUIPMENT	FURNISHED BY	INSTALLED BY
C.T. ENCLOSURE, GROUNDING LUGS, PLYWOOD, POWER BLOCKS AND CONDUIT	CONTRACTOR	CONTRACTOR
C.T.'S, TEST BOXES	UTILITY	CONTRACTOR
SECONDARY WIRING	UTILITY	UTILITY

*FOR 1200A SERVICES MINIMUM CABINET SIZE 48"X48"X14" IS REQUIRED DUE TO SIZE OF C.T.'S

CONTRACTOR NOTES:

- CONTRACTOR SHALL PROVIDE BONDING FOR C.T. & METER BASE AND SHALL GROUND EQUIPMENT PER N.E.C. AND LOCAL CODES.
- CONTRACTOR SHALL INSTALL EQUIPMENT AT THE LOCATION DESIGNATED BY LG&E SERVICE LOCATORS OR METER DEPARTMENT SUPERVISORS.
- THE POLARITY MARKS ON EACH CURRENT TRANSFORMER SHOULD POINT TOWARD THE LINE OR FEED CONDUCTORS.
- THE INSTALLATION MUST BE ACCEPTABLE TO UTILITY BEFORE THE SERVICE IS ENERGIZED.
- LINE CONDUCTORS SHALL ENTER & LOAD CONDUCTORS SHALL EXIT ON OPPOSITE SIDES OF THE CABINET (i.e. BOTTOM TO TOP OR SIDE TO SIDE). POWER BLOCK & C.T. LAYOUT SHALL BE ROTATED AS NECESSARY TO KEEP POWER BLOCKS CONNECTED ON LINE SIDE OF C.T.
- POWER BLOCKS SHALL BE 2 LUG ILSKO #LDB-22-500-LG, IIN 3023975 (WHICH INCLUDES ILSKO #SLUH-90 LUG FOR TAP), 5 LUG ILSKO #PDB-55-600-1 OR PDB-55-500-1 OR APPROVED EQUAL.
- PROVIDE WIRE TIES FOR MULTIPLE CABLES PER LEG TO KEEP THE CABLES FROM PUTTING STRAIN ON C.T.

WINDOW TYPE CT

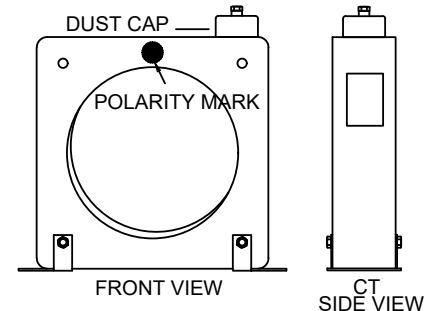

NOTE:

1. THE C.T. ENCLOSURE SHALL NOT BE USED AS AN AUXILIARY GUTTER OR JUNCTION BOX.
2. DIAGRAM SHOWN FOR OH SERVICE. FOR UG SERVICE, ROTATE INTERNAL LAYOUT 180°.

MINIMUM C.T. ENCLOSURE SIZE USING 1 OR 2 CABLES PER PHASE
120/208V 3Ø 4W >400-800A - 277/480V 3Ø 4W - >200-800AMP MAX (LGE/KU)
120/240V 3Ø 4W >400-800A

METER BASE TO BE
GROUNDED TO
SYSTEM GROUND
WITH MINIMUM #6
COPPER

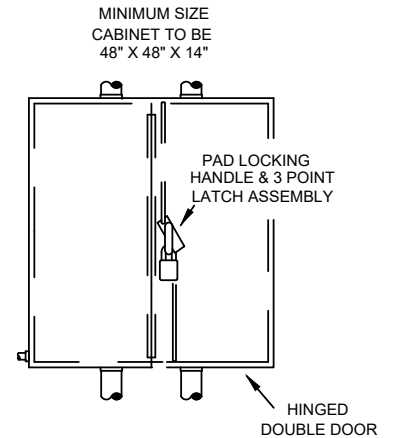
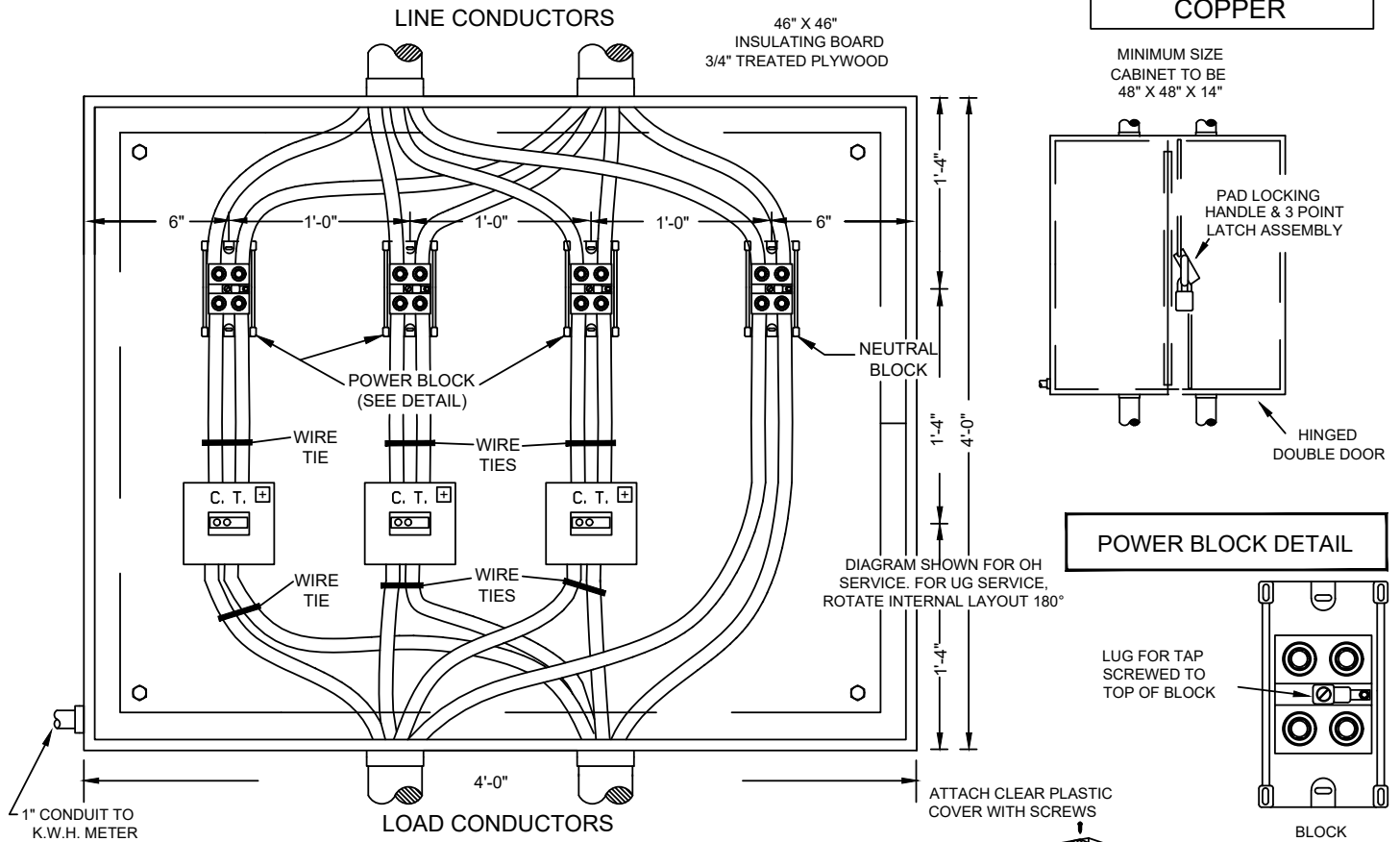

POWER BLOCK DETAIL

DIAGRAM SHOWN FOR OH SERVICE. FOR UG SERVICE, ROTATE INTERNAL LAYOUT 180°

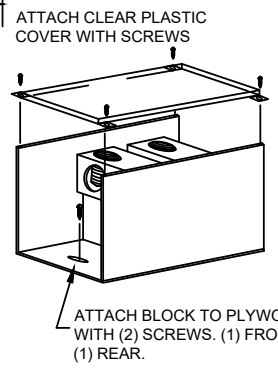
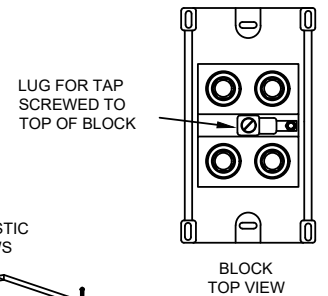

NUMBER OF CONDUCTORS	MAXIMUM CONDUCTOR SIZE	
	COPPER	ALUMINUM
SINGLE (MAX OF 1 PER LEG)	500MCM	500MCM
PARALLEL (MAX OF 2 PER LEG)	500MCM	500MCM

EQUIPMENT	FURNISHED BY	INSTALLED BY
C.T. ENCLOSURE, GROUNDING, LUGS, PLYWOOD, POWER BLOCKS AND CONDUIT	CONTRACTOR	CONTRACTOR
C.T.'S AND METER ENCLOSURES	UTILITY	CONTRACTOR
METER AND SECONDARY WIRING	UTILITY	UTILITY

CONTRACTOR NOTES:

1. CONTRACTOR SHALL PROVIDE BONDING FOR C.T. & METER BASE AND SHALL GROUND EQUIPMENT PER N.E.C. AND LOCAL CODES.
2. CONTRACTOR SHALL INSTALL EQUIPMENT AT THE LOCATION DESIGNATED BY LG&E/KU SERVICE LOCATOR/DESIGNER OR METER DEPARTMENT SUPERVISORS.
3. THE POLARITY MARKS ON EACH CURRENT TRANSFORMER SHOULD POINT TOWARD THE LINE OR FEED CONDUCTORS.
4. THE INSTALLATION MUST BE ACCEPTABLE TO LG&E/KU BEFORE THE SERVICE IS ENERGIZED.
5. LINE CONDUCTORS SHALL ENTER & LOAD CONDUCTORS SHALL EXIT ON OPPOSITE SIDES OF THE CABINET (i.e. BOTTOM TO TOP OR SIDE TO SIDE). POWER BLOCKS & C.T. LAYOUT SHALL BE ROTATED AS NECESSARY TO KEEP POWER BLOCKS CONNECTED ON LINE SIDE OF C.T.
6. POWER BLOCKS SHALL BE ILSCO #LDB-22-500-LG IIN 3023975 (WHICH INCLUDES ILSCO #SLUH-90 LUG FOR TAP) OR APPROVED EQUAL.
7. PROVIDE WIRE TIES FOR MULTIPLE CABLES PER LEG TO KEEP THE CABLES FROM PUTTING STRAIN ON C.T.

WINDOW TYPE CT

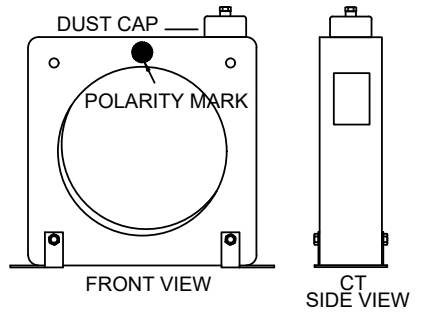

NOTE:

1. THE C.T. ENCLOSURE SHALL NOT BE USED AS AN AUXILIARY GUTTER OR JUNCTION BOX.
2. DIAGRAM SHOWN FOR OH SERVICE. FOR UG SERVICE, ROTATE INTERNAL LAYOUT 180°.

MINIMUM C.T. ENCLOSURE SIZE USING UP TO 5 CABLES PER PHASE
120/208V 3Ø 4W - 277/480V 3Ø 4W >800AMP - 2000 MAX

METER BASE TO BE
GROUNDED TO
SYSTEM GROUND
WITH MINIMUM #6
COPPER

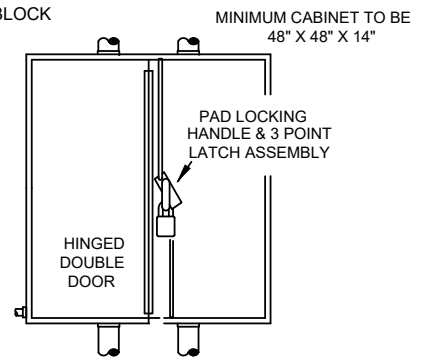
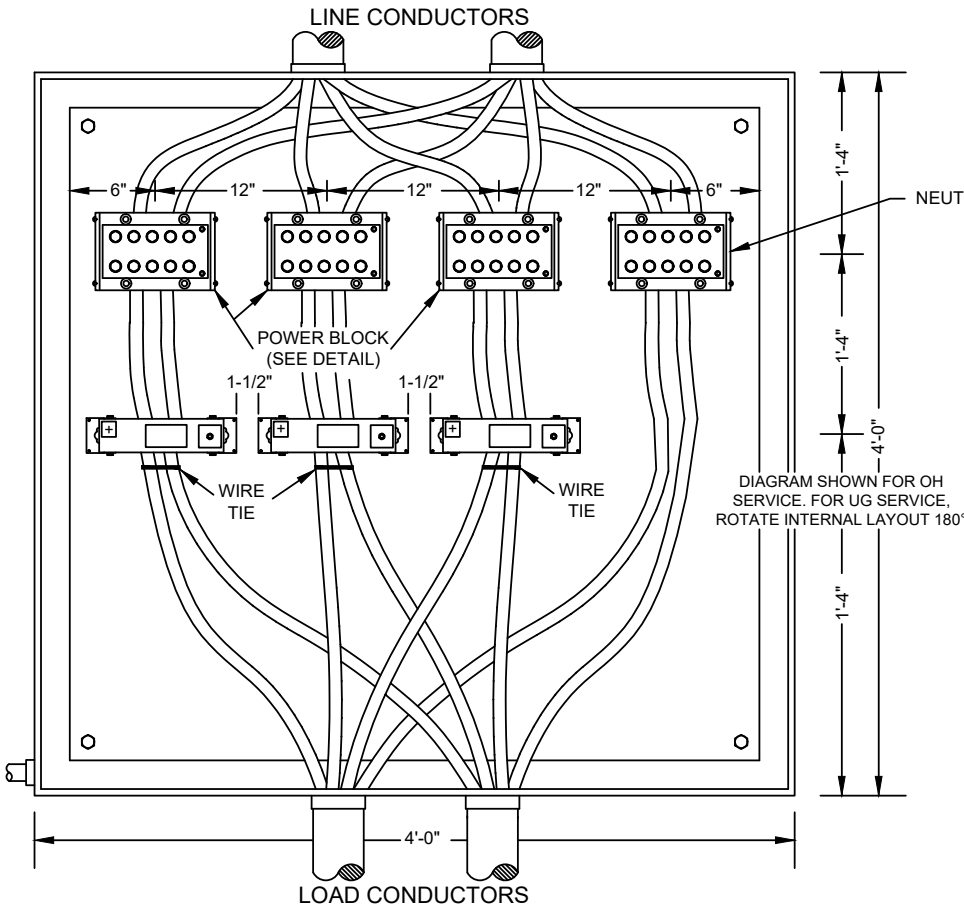

WINDOW TYPE CT

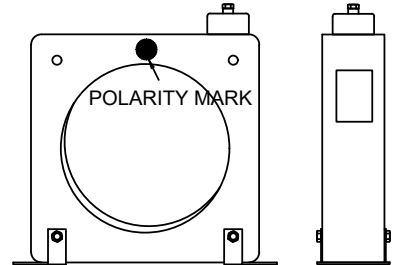

NUMBER OF CONDUCTORS	MAXIMUM CONDUCTOR SIZE	
	COPPER	ALUMINUM
PARALLEL (MAX OF 5 PER LEG)	600MCM	600MCM

EQUIPMENT	FURNISHED BY	INSTALLED BY
C.T. ENCLOSURE, GROUNDING LUGS, PLYWOOD, POWER BLOCKS AND CONDUIT	CONTRACTOR	CONTRACTOR
C.T.'S AND TEST BOXES	UTILITY	CONTRACTOR
METER AND SECONDARY WIRING	UTILITY	UTILITY

CONTRACTOR NOTES:

1. CONTRACTOR SHALL PROVIDE BONDING FOR C.T. & METER BASE AND SHALL GROUND EQUIPMENT PER N.E.C. AND LOCAL CODES.
2. CONTRACTOR SHALL INSTALL EQUIPMENT AT THE LOCATION DESIGNATED BY LG&E/KU SERVICE LOCATOR/DESIGNER OR METER DEPARTMENT SUPERVISORS.
3. THE POLARITY MARKS ON EACH CURRENT TRANSFORMER SHOULD POINT TOWARDS THE LINE OR FEED CONDUCTORS.
4. THE INSTALLATION MUST BE ACCEPTABLE TO LG&E/KU BEFORE THE SERVICE IS ENERGIZED.
5. POWER BLOCKS & C.T. LAYOUT SHALL BE ROTATED AS NECESSARY TO KEEP POWER BLOCKS CONNECTED ON LINE SIDE OF C.T.
6. POWER BLOCKS SHALL BE ILSCO #PDB-55-600-1 OR PDB-55-500-1 OR APPROVED EQUAL.
7. PROVIDE WIRE TIES FOR MULTIPLE CABLES PER LEG TO KEEP THE CABLES FROM PUTTING STRAIN ON C.T.

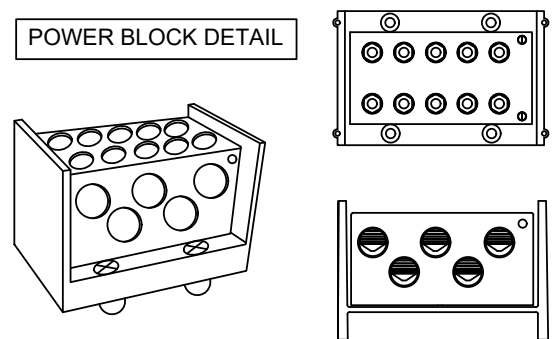

NOTE: SWITCHGEAR METERING IS POSSIBLE WHEN PADMOUNT & CABINET MOUNTED METERING IS IMPOSSIBLE (KU ONLY)

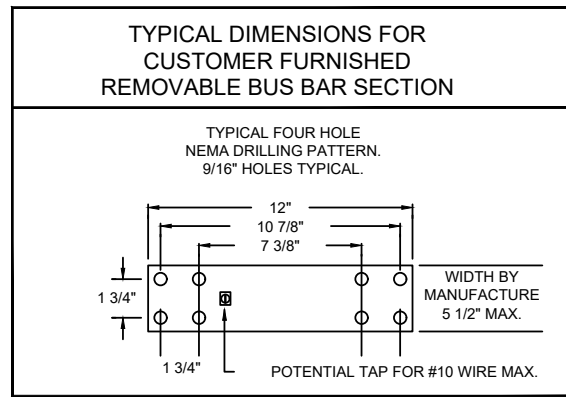
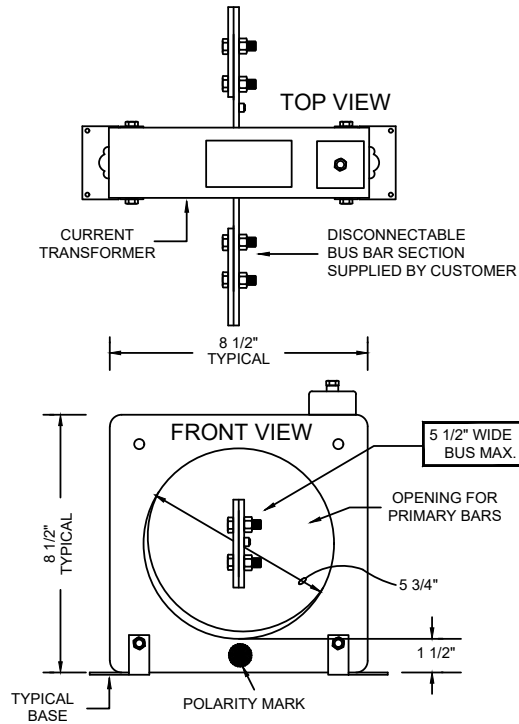

WINDOW TYPE CURRENT TRANSFORMER INSTALLATION

METERING COMPARTMENT FOR SWITCH GEAR

METER BASE TO BE GROUNDED TO SYSTEM GROUND WITH MINIMUM #6 COPPER

NOTES:
DIMENSIONS AS NOTED ARE MINIMUM STANDARDS FOR C.T. SEPARATION. DISTANCE BETWEEN LIVE PARTS SHOULD NOT BE LESS THAN 2".

CONTRACTORS ARE REQUESTED TO CALL T & D DESIGN DEPARTMENT BEFORE PROCEEDING WITH SAME.

1" CONDUIT TO BE INSTALLED FROM METER BASE INTO C.T. COMPARTMENT AND STUBBED OFF.

CURRENT TRANSFORMERS TO BE FURNISHED BY UTILITY.

COPPER OR ALUMINUM BUS BAR CAPACITY AS REQUIRED.

ALL POLARITY MARKS ON C.T. SHOULD BE FACING LINE SIDE OR FEED SIDE.

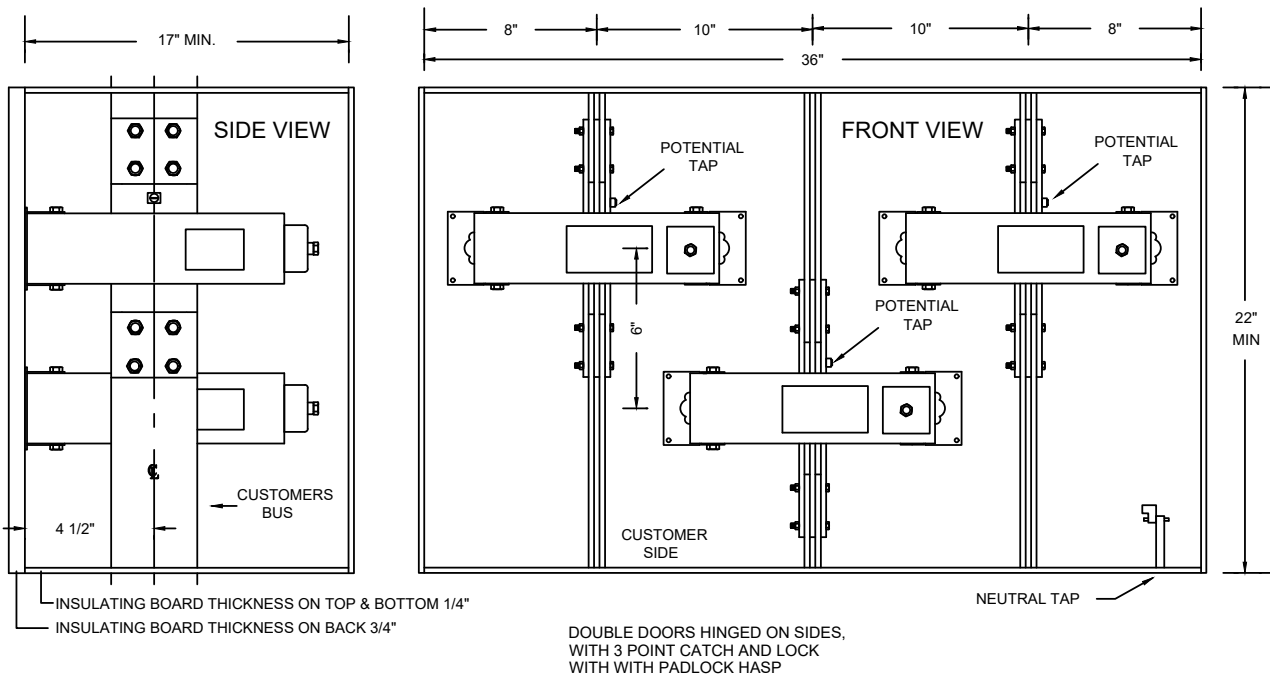

The utility's service representative will make the final determination on the location of the meter base when transformer mounted metering equipment is approved.

General

The standard metering arrangement for large services requires both a meter base and a Customer provided compartment to house instrument transformers (generally Current Transformers (C.T.'s)). Under special conditions when service is provided underground directly from a padmount transformer, the metering transformers can be located inside the secondary compartment of the transformer eliminating the need for a separate CT compartment. Installations with multiple customers not suitable for transformer mounted metering (KU only).

1. All transformer mounted C.T.'s installations must be pre-approved by the utility.
2. Service must be provided directly from a padmount transformer that will never be expected to provide service to more than a single customer and the transformer is not to be used to serve auxiliary loads like fire protection equipment or utility provided lighting.
3. A meter base can be located near (2'-0" min. or 30'-0" max.) the padmount transformer in a secure, accessible location on private property. Typical locations for the meter base will be on a customer provided support adjacent to the transformer or on the wing wall of a fire containment enclosure if required. Other locations as determined by the Company's service representative may also be approved.

Customer Responsibilities

The customer is responsible for providing the transformer pad, trenching and backfill, conduit, meter stand and meter stand grounding and service cables. Utility provided meter base to be installed by Customer. All material to be installed in conformance with utility standards and subject to the approval of the utility.

Utility Installed Items

The utility provides the padmount transformer, transformer grounding, service connectors, metering transformers and associated wiring and the electric meter. The utility will connect the customer's service and grounding cables inside the transformer once all the requirements for service have been met.

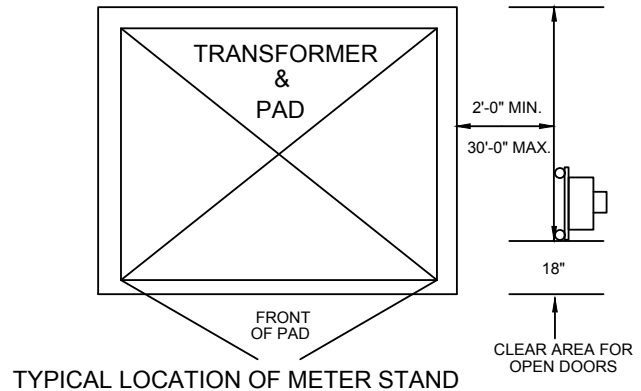
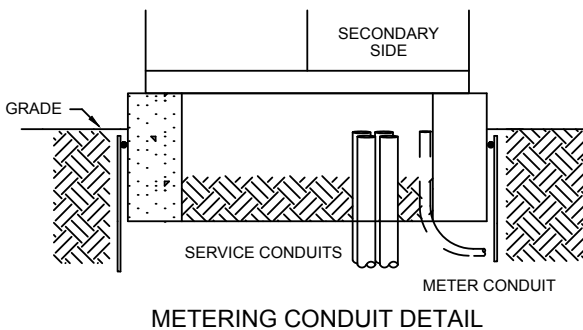
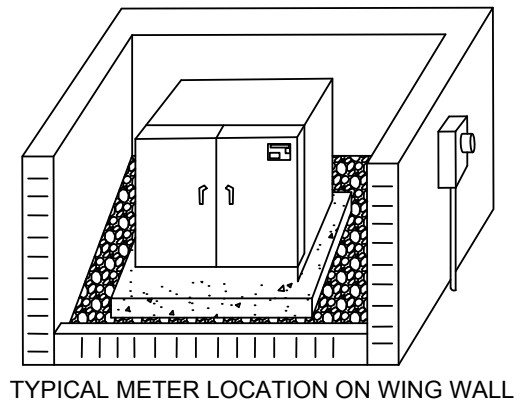
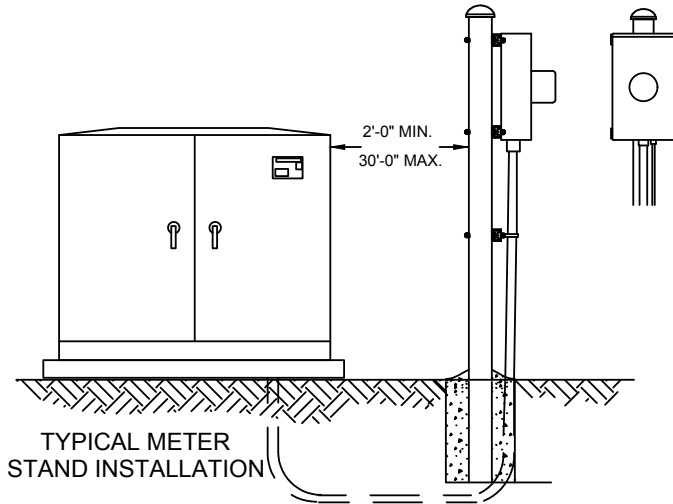

(SEE SHEET 2 OF THIS STANDARD FOR COMPLETE CONSTRUCTION DETAILS.)

The utility's service representative will make the final determination on the location of the meter base when transformer mounted metering equipment is approved.

Conduit Notes:

Meter wiring conduit to be a minimum of 1-1/2" Schedule 80 PVC or rigid metal. Ground lead conduit to be a 1/2" Schedule 80 PVC or rigid metal. A pulling tape should be pre-installed in the 1-1/2" conduit.

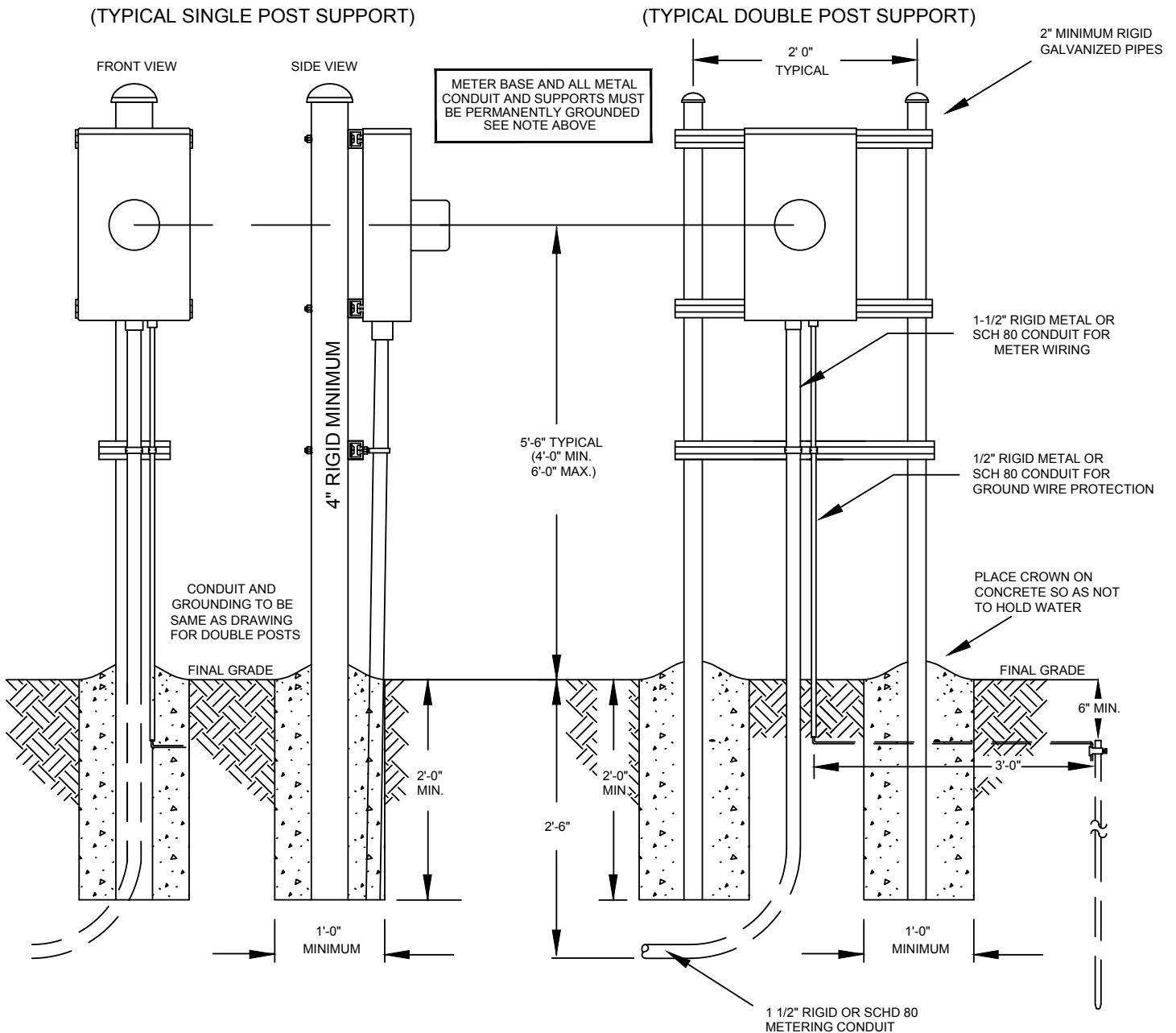

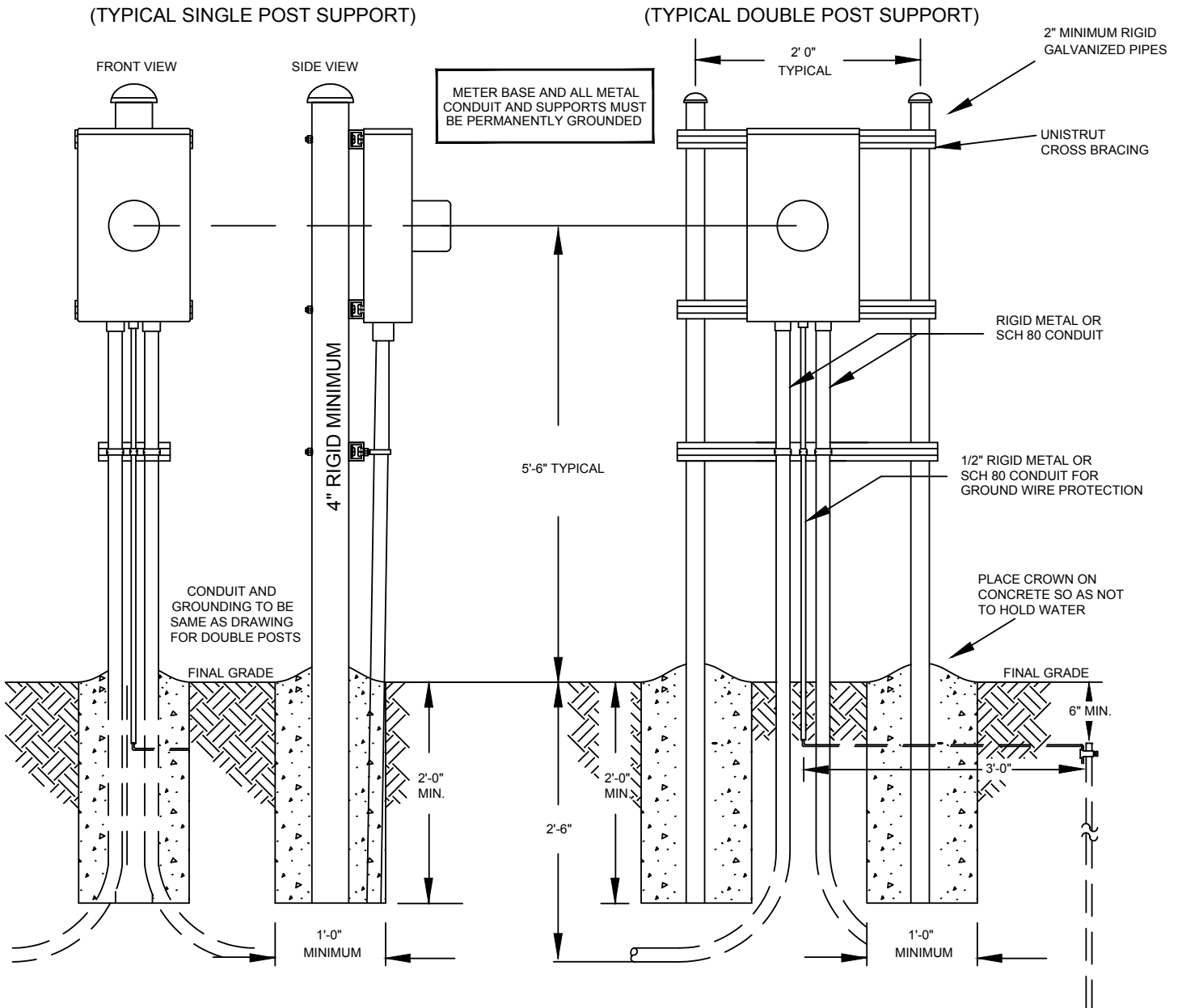

TYPICAL 120/240V, 1Ø, 3W, 400 AMP METER
BASE WITH CLASS 320 METER

NOTE:

1. The meter socket enclosure shall not be used as an auxiliary gutter or junction box.

TYPICAL METER INSTALLATION FOR
OVERHEAD SERVICE 1 OR 2 CABLES
PER PHASE

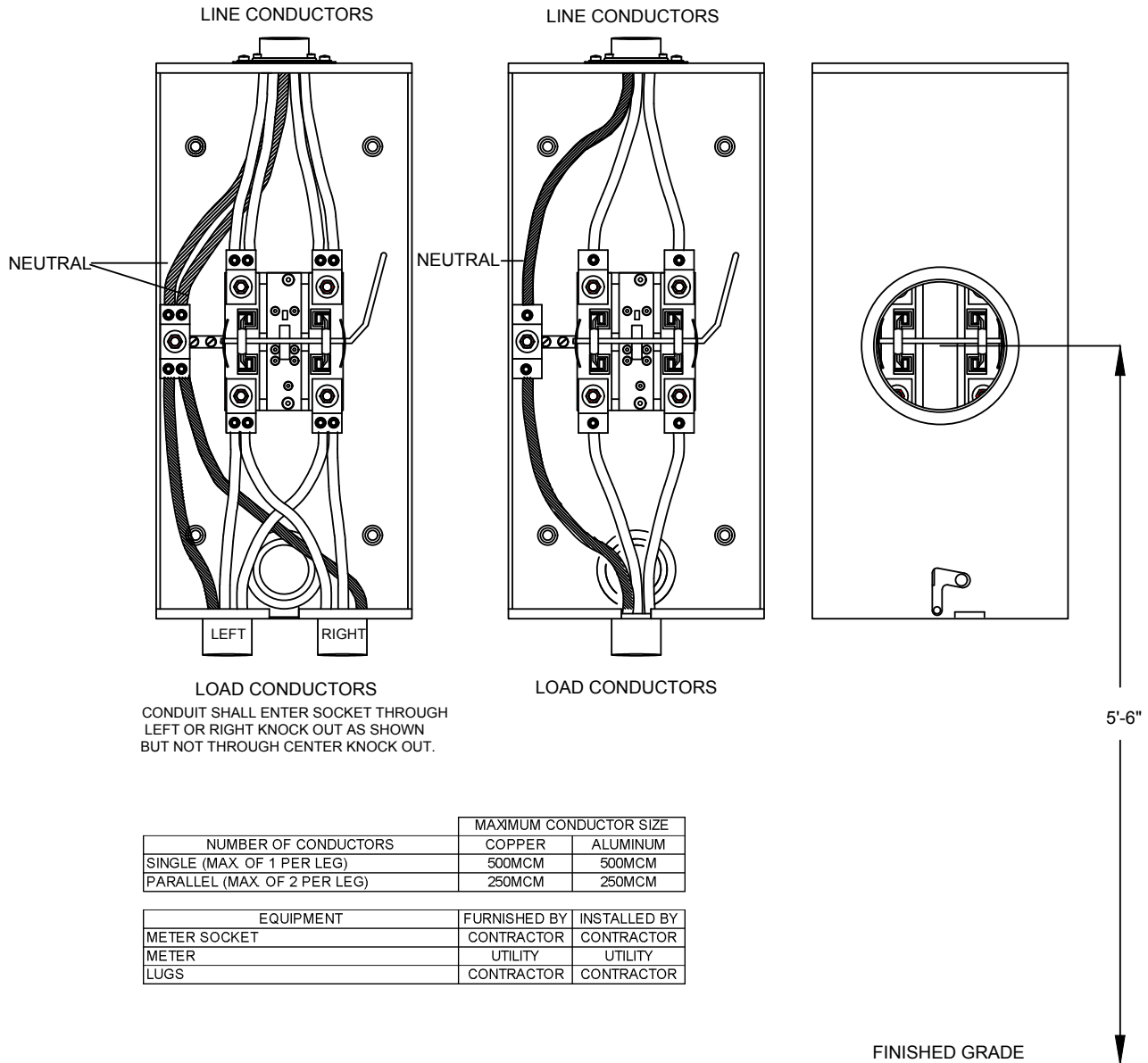

NUMBER OF CONDUCTORS	MAXIMUM CONDUCTOR SIZE	
	COPPER	ALUMINUM
SINGLE (MAX. OF 1 PER LEG)	500MCM	500MCM
PARALLEL (MAX. OF 2 PER LEG)	250MCM	250MCM

EQUIPMENT	FURNISHED BY	INSTALLED BY
METER SOCKET	CONTRACTOR	CONTRACTOR
METER	UTILITY	UTILITY
LUGS	CONTRACTOR	CONTRACTOR

CONTRACTOR NOTES:

- Contractor shall install equipment at the location designated by LG&E/KU Service Locators or Meter Department Supervisors.
- The installation must be acceptable to LG&E/KU before the service is energized.
- Contractors to Supply and Install Lugs for Meter Base.

ALTERNATE BASE NOT PROVIDED BUT, ACCEPTABLE TO BOTH UTILITIES

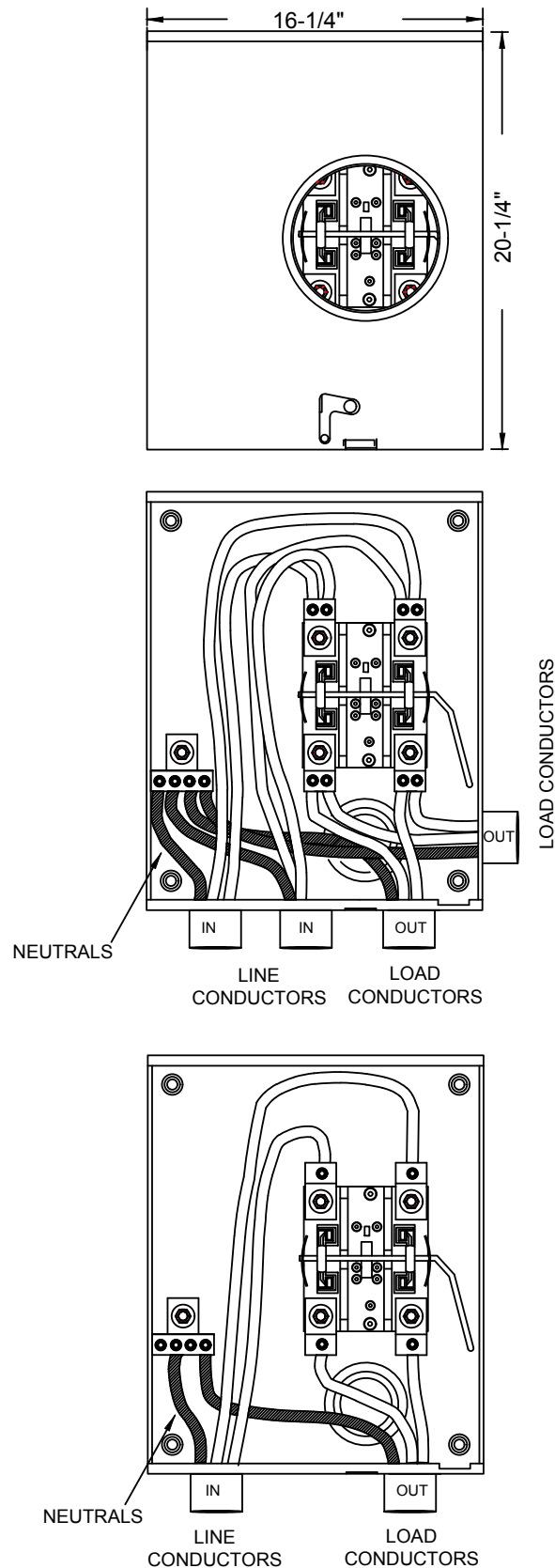

GENERAL NOTES:

- GROUND CLEARANCE SHOULD EXCEED NESC MINIMUMS TO THE EXTENT PRACTICAL TO ENSURE COMPLIANCE UNDER ALL LOADING CONDITIONS THROUGHOUT THE LIFE OF THE INSTALLATION. **SEE STANDARD 02 10 10** FOR NESC GROUND CLEARANCE REQUIREMENTS. SERVICE LINES NOT ENGINEERED AND SAGGED DURING INSTALLATION SHOULD NOT EXCEED 100' IN LENGTH AND MEASURED GROUND CLEARANCE SHOULD EXCEED NESC REQUIREMENTS AT ALL LOCATIONS IN THE SPAN BY A MINIMUM OF 12 INCHES.
- CUSTOMER'S FACILITIES TO BE INSTALLED IN ACCORDANCE WITH ALL NATIONAL, STATE AND LOCAL CODES OR REGULATIONS.
- UTILITY TO PROVIDE SERVICE DROP, ATTACHMENT CLAMP, SERVICE CONNECTORS AND METER. ALL OTHER MATERIALS INCLUDING METER BASE TO BE PROVIDED AND INSTALLED BY CUSTOMER.
- GROUNDING/BONDING
 - KU** - GROUNDING ELECTRODE CONDUCTOR MAY BE BONDED TO THE GROUNDED SERVICE CONDUCTOR WITHIN THE METER BASE OR INSIDE THE SERVICE PANEL AS ALLOWED BY LOCAL JURISDICTIONAL AUTHORITY.
 - LG&E** - GROUNDING ELECTRODE CONDUCTOR MUST BE BONDED WITHIN THE SERVICE PANEL AND NOT IN THE METER BASE AS REQUIRED BY LOCAL JURISDICTIONAL AUTHORITIES.

OVERHEAD SERVICE
UNDER ROOF ATTACHMENT

NOTES:

- CUSTOMER TO PROVIDE SUITABLE ATTACHMENT POINT. LOCATION AND HEIGHT OF POINT FOR ATTACHMENT OF SERVICE CONDUCTORS MUST BE SPECIFIED AND APPROVED BY UTILITY. ACCEPTABLE POINTS OF ATTACHMENT ARE THE BUILDING STUDS, MORTAR JOINTS AND RAFTERS. UNACCEPTABLE POINTS OF ATTACHMENT ARE THE OUTSIDE TRIM BOARD, INSIDE TRIM BOARD, SOFFIT BOARD, FASCIA BOARD, FIRE WALLS, PARAPET WALLS OR CHIMNEYS. (OUTSIDE TRIM BOARD, INSIDE TRIM BOARD AND SOFFIT BOARDS MAY BE ATTACHED TO IF ADEQUATELY REINFORCED.)
- POINT OF ATTACHMENT SHOULD NOT BE FARTHER THAN 2' FROM THE WEATHERHEAD AND INSTALLED BY THE ELECTRICIAN TO TERMINATE UTILITY SERVICE.

ENERGIZED SERVICE DROP CONDUCTORS, INCLUDING SPLICES AND TAPS, SHALL BE INSULATED OR COVERED. FOR SERVICES UP TO 750V, SERVICE CAN CONSIST OF COVERED OR INSULATED SINGLE CONDUCTORS OR MULTIPLEX SERVICE CABLES.

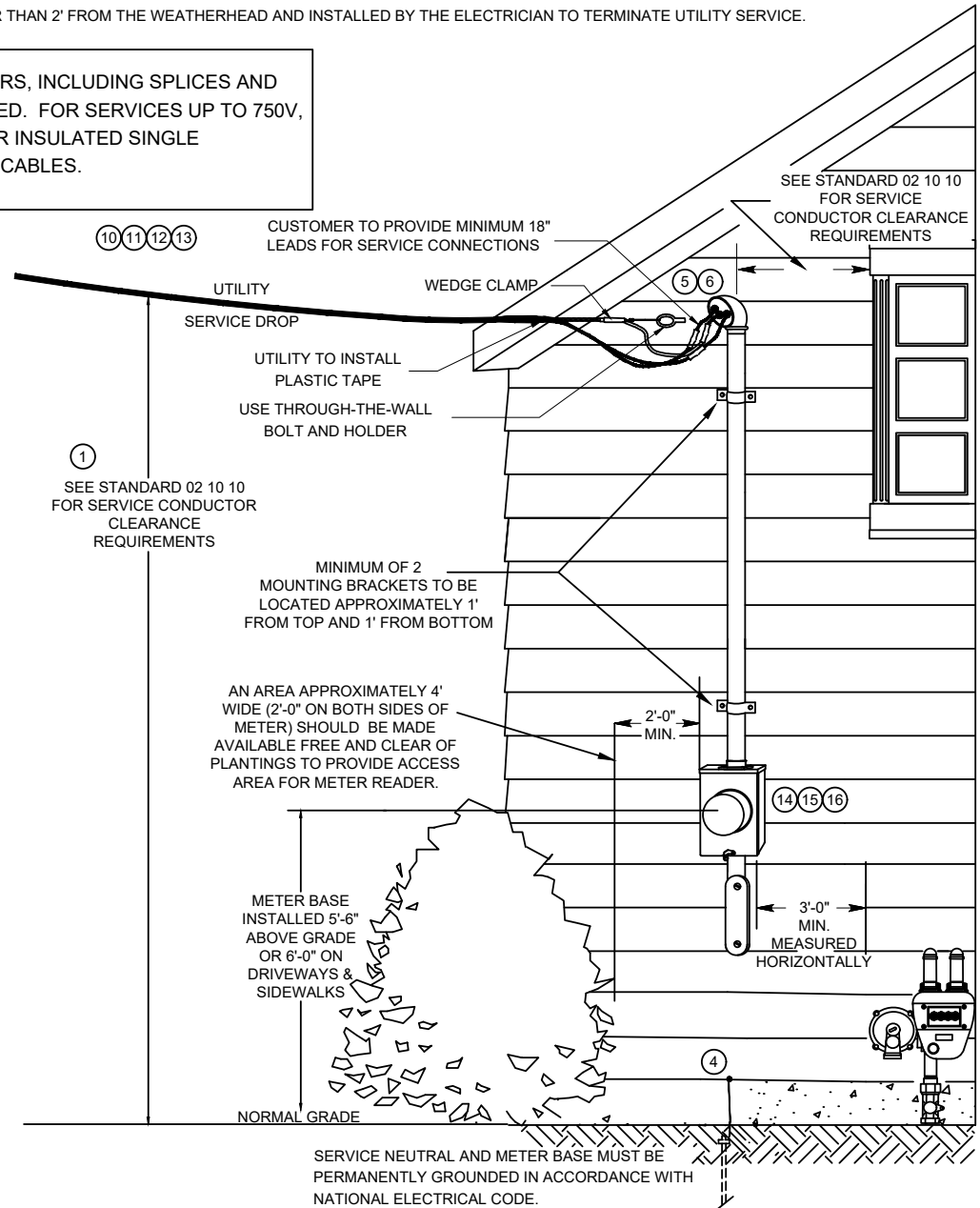

OVERHEAD SERVICE
ABOVE ROOF ATTACHMENT

FOR GENERAL NOTES SEE PAGE 1

NOTES:

7. A SERVICE MAST IS REQUIRED WHEN IT IS NOT POSSIBLE TO MAINTAIN 12' CLEARANCE FROM FINISHED GRADE TO THE LOWEST POINT OF THE CONDUCTOR INCLUDING THE DRIP LOOP UNDER ALL LOADING CONDITIONS THROUGHOUT THE LIFE OF THE INSTALLATION. VERTICAL CLEARANCE OF CONDUCTOR TO ROOF SURFACE DEPENDS ON THE SLOPE OF THE ROOF. SEE NEC 230-24(A).
8. MINIMUM 2" RIGID STEEL CONDUIT TO BE USED FOR RISERS THROUGH THE ROOF ON 100A SERVICES. A MINIMUM OF 2-1/2" WILL BE REQUIRED FOR 200A SERVICES UNLESS APPROVED BY THE UTILITY. A MINIMUM OF 3" WILL BE REQUIRED FOR 400A SERVICES UNLESS APPROVED BY THE UTILITY. FOR SERVICES LARGER THAN 400A, SEEK GUIDANCE FROM THE UTILITY. UTILITY MAY REQUIRE ADDITIONAL GUYING, STRAPPING AND/OR LARGER CONDUIT SIZE WHERE SERVICE DROPS ARE LONG OR LARGER CONDUCTORS ARE USED. RISER TO BE SECURELY BLOCKED AND STRAPPED IN RAFTERS AND A MINIMUM OF TWO CONDUIT STRAPS ARE REQUIRED BELOW THE SOFFIT.
9. LOCATION AND HEIGHT OF POINT FOR ATTACHMENT OF SERVICE CONDUCTORS MUST BE SPECIFIED AND APPROVED BY UTILITY.

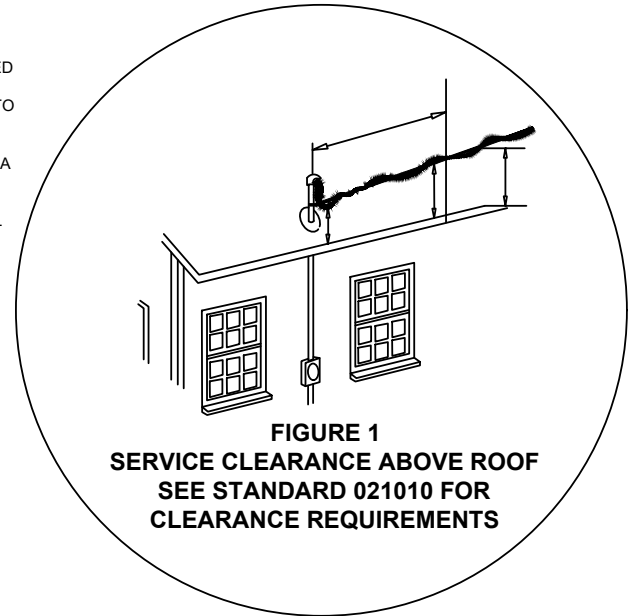
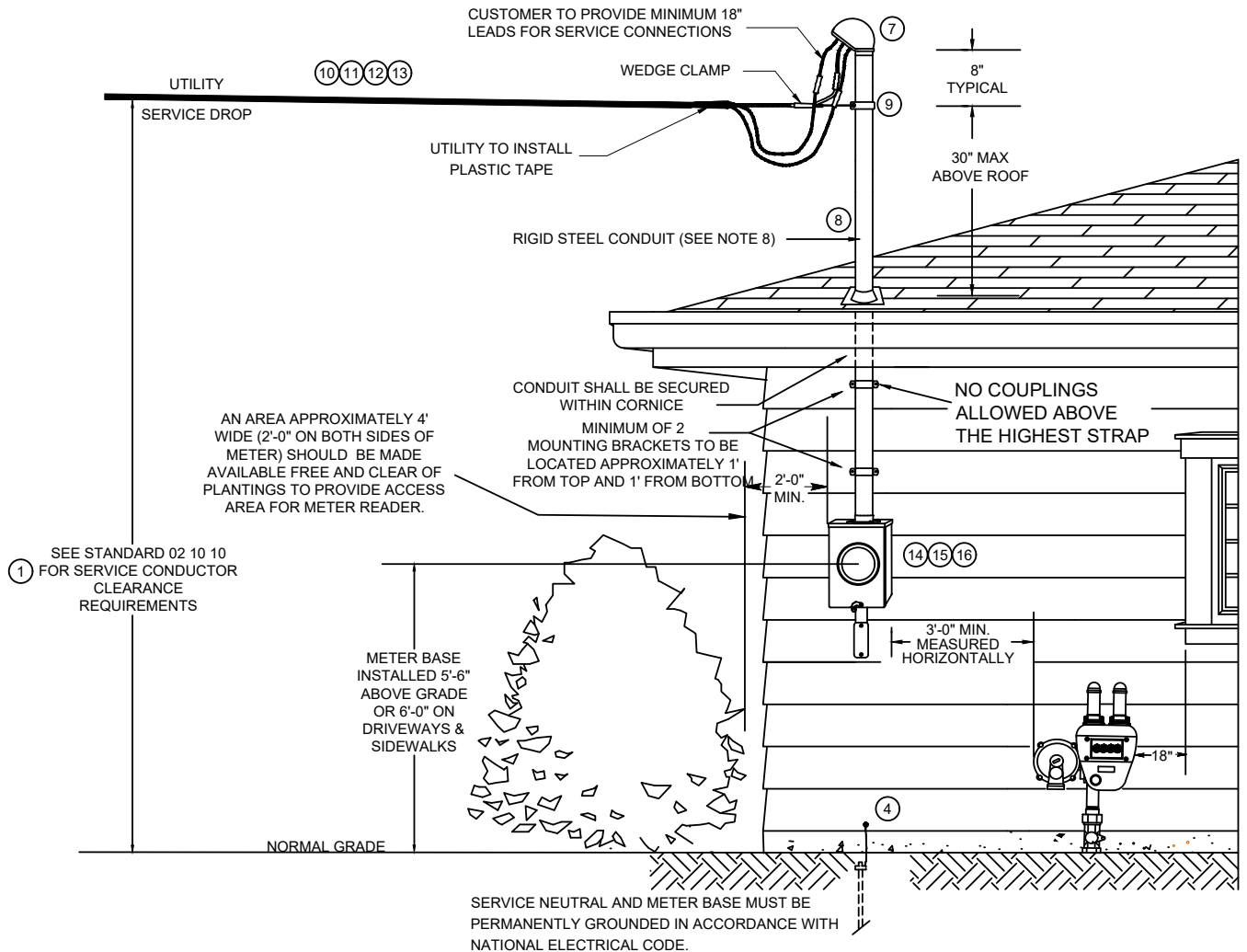

FIGURE 1
SERVICE CLEARANCE ABOVE ROOF
SEE STANDARD 021010 FOR
CLEARANCE REQUIREMENTS

ENERGIZED SERVICE DROP CONDUCTORS, INCLUDING SPLICES AND TAPS, SHALL BE INSULATED OR COVERED. FOR SERVICES UP TO 750V, SERVICE CAN CONSIST OF COVERED OR INSULATED SINGLE CONDUCTORS OR MULTIPLEX SERVICE CABLES.



NOTES:

10.

TYPICAL OVERHEAD TRIPLEX CONDUCTOR FOR 1Ø SERVICE*			
IIN#	DESCRIPTION	SERVICE	MAX. LENGTH
3032815	TWO INSULATED #2 AL AND ONE BARE #2 ACSR NEUTRAL	100 AMPS	150 FEET
3032814	TWO INSULATED 1/0 AL AND ONE BARE 1/0 ACSR NEUTRAL	200 AMPS	100 FEET
3028737	TWO INSULATED 4/0 AL AND ONE BARE 4/0 ACSR NEUTRAL	400 AMPS	100 FEET

11.

TYPICAL OVERHEAD QUADRUPLIX CONDUCTOR FOR 3Ø SERVICE*			
IIN#	DESCRIPTION	SERVICE	MAX. LENGTH
1197686	THREE INSULATED 1/0 AL AND ONE BARE 1/0 ACSR NEUTRAL	200 AMPS	75 FEET
1197694	THREE INSULATED 4/0 AL AND ONE BARE 4/0 ACSR NEUTRAL	400 AMPS	75 FEET

12. A LEGACY 397 SERVICE DROP SHOULD NEVER BE SPLICED
13. FOR SERVICE GREATER THAN 400 AMPS, THE SERVICE CONDUCTOR SHALL BE SPECIFIED BY THE UTILITY'S LOCAL ENGINEER, BASED ON A CUSTOMER PROVIDED LOAD DATA.
14. INSTRUMENT RATED METERING IS REQUIRED FOR ALL SERVICES ABOVE 400 AMPS. SEE STANDARDS 81 10 XX FOR DETAILS.
15. 480 VOLT SERVICE NOT IN EXCESS OF 200A MUST UTILIZE SELF-CONTAINED METERING USING A DISCONNECT SWITCH AHEAD OF THE METER (STANDARD 81 20 12).
16. 480 VOLT SERVICE GREATER THAN 200 AMPS MUST UTILIZE INSTRUMENT RATED METERING (STANDARDS 81 10 XX).

TYPICAL 1Ø RINGLESS METER BASE

APPROVED CUSTOMER PROVIDED
RINGLESS METER BASE

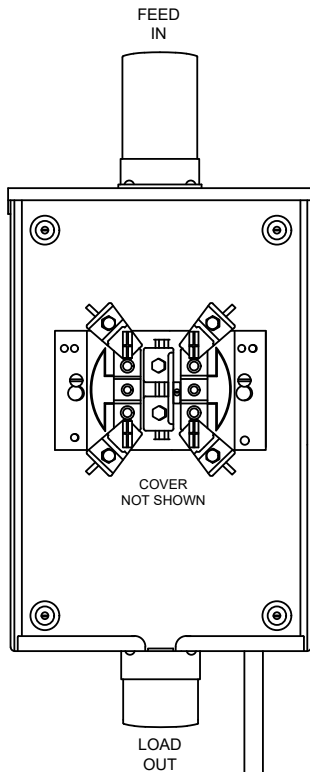

TYPICAL 3Ø RINGLESS METER BASE

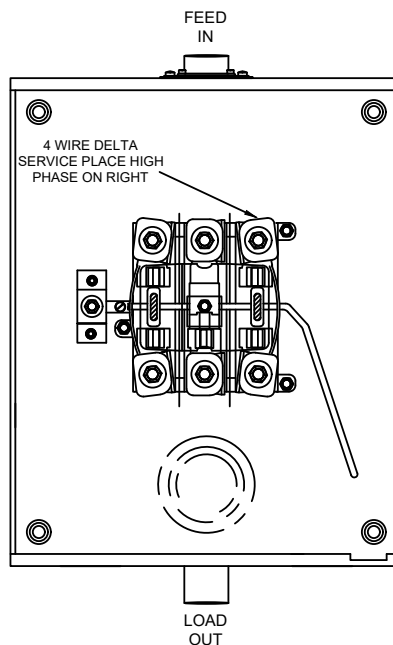

TYPICAL 480V RINGLESS METER BASE

SEE STANDARD 812012 FOR 480V
DISCONNECT REQUIREMENTS

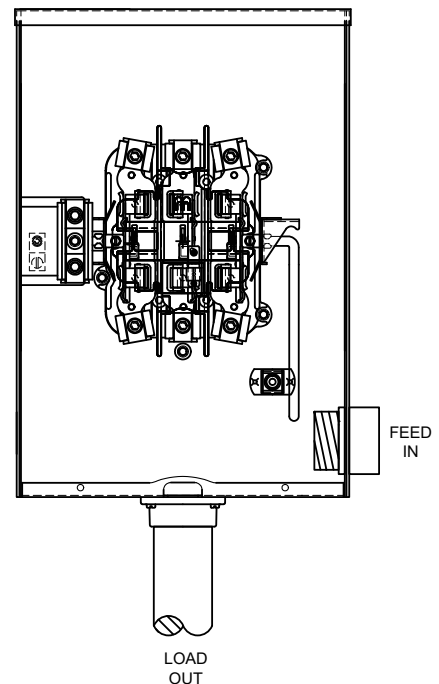

FOR 120/208 VOLT 1Ø SERVICE, THE CUSTOMER PROVIDED METER BASE SHALL BE A FIFTH LUG DESIGN.

METER BASES MUST BE GROUNDED PER NEC CODE

NOTES:

1. THIS STANDARD DETAILS THE NUMBERING OF ELECTRIC MULTI-METER INSTALLATIONS.
2. LG&E/KU MUST VERIFY THAT SERVICES HAVE BEEN MARKED WITH CORRECT UNIT NUMBER BY ELECTRICIAN.
3. SERVICE POINTS SHOULD BE PERMANENTLY MARKED WITH THE UNIT NUMBER ON THE INSIDE OF THE METER BASE NEXT TO THE BLOCK USING PERMANENT MARKER OR PAINT PEN.
4. SERVICES ARE TO BE LABELED USING 1" POLYMER DIGITS CONSISTING OF THE UNIT NUMBER FOR THAT SERVICE. NUMBERS MUST MATCH THE NUMBERING ON THE UNIT.
5. 1" POLYMER DIGITS ARE TO BE PLACED ABOVE EACH BREAKER USING SILICONE ADHESIVE. FOR METER BASE WHERE BREAKERS ARE LOCATED BELOW THE METER UNIT NUMBER SHOULD BE PLACED NEXT TO THE BREAKER.
6. UNIT NUMBERS ARE NOT TO BE PLACED ON THE METER BASE LIDS AS TO AVOID THE SWITCHING OF LIDS.

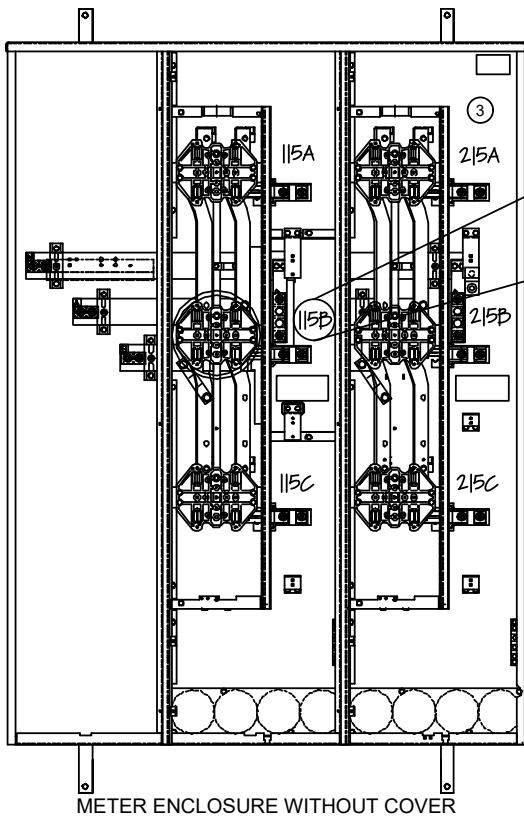
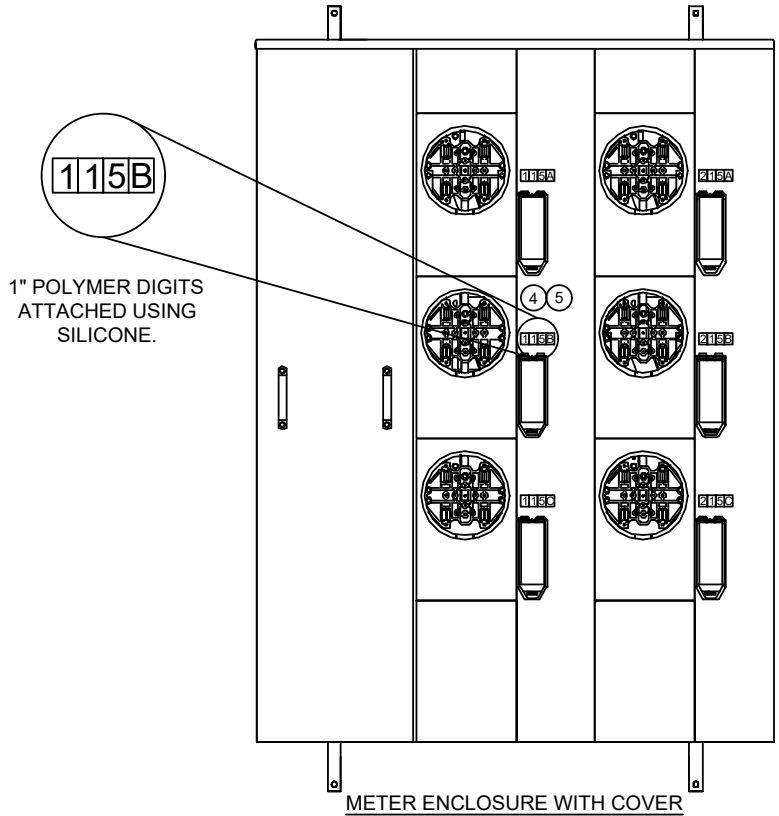

MARK UNIT NUMBER ON METER BASE WITH PERMANENT MARKER OR PAINT PEN.

NOTES:

1. GROUND CLEARANCE SHOULD EXCEED NESC MINIMUMS TO THE EXTENT PRACTICAL TO ENSURE COMPLIANCE UNDER ALL LOADING CONDITIONS THROUGHOUT THE LIFE OF THE INSTALLATION. **SEE STANDARD 02 10 10** FOR NESC CLEARANCE REQUIREMENTS. SERVICE LINES NOT ENGINEERED AND SAGGED DURING INSTALLATION SHOULD NOT EXCEED 100' IN LENGTH AND MEASURED GROUND CLEARANCE SHOULD EXCEED NESC REQUIREMENTS AT ALL LOCATIONS IN THE SPAN BY A MINIMUM OF 12 INCHES.
2. CUSTOMER'S FACILITIES TO BE INSTALLED IN ACCORDANCE WITH ALL NATIONAL, STATE AND LOCAL CODES OR REGULATIONS.
3. LOCATION AND HEIGHT OF POINT FOR ATTACHMENT OF SERVICE CONDUCTORS MUST BE SPECIFIED AND APPROVED BY UTILITY.
4. ATTACHMENT MUST BE ADEQUATE TO PREVENT DAMAGE TO CUSTOMER'S PROPERTY AT MAXIMUM TENSION. SERVICE ENTRANCE HEAD SHOULD BE ABOVE AND NOT FARTHER THAN 24" FROM POINT OF SERVICE ATTACHMENT.
5. UTILITY TO PROVIDE SERVICE DROP, ATTACHMENT CLAMP, SERVICE CONNECTORS AND METER. ALL OTHER MATERIALS INCLUDING METER BASE TO BE PROVIDED AND INSTALLED BY CUSTOMER.
6. NOTIFY UTILITY FOR METER INSTALLATION.
7. MOUNTING PROVISIONS SPECIFIED BY UTILITY. MOUNTING BRACKET FURNISHED AND INSTALLED BY CUSTOMER.
8. WEATHERHEAD(S) TO BE LOCATED AT OR ABOVE THE POINT OF SERVICE ATTACHMENT. PROVIDE MINIMUM 18" LEADS FOR SERVICE CONNECTIONS.
9. GANG METER BASE WITH MAIN DISCONNECT OR SEPARATE INDIVIDUAL DISCONNECTS FOR EACH TENANT TO BE FURNISHED BY CUSTOMER. METER BASE TO INCLUDE LOCKING HATCH AND PADLOCK EYE. ALL DISCONNECTS TO BE INSTALLED ON CUSTOMER'S SIDE OF METER.
10. SEE STANDARD# 812003 FOR DETAILS ON LABELING MULTI-FAMILY METERS.

ENERGIZED SERVICE DROP CONDUCTORS, INCLUDING SPLICES AND TAPS, SHALL BE INSULATED OR COVERED. FOR SERVICES UP TO 750V, SERVICE CAN CONSIST OF COVERED OR INSULATED SINGLE CONDUCTORS OR MULTIPLEX SERVICE CABLES. SERVICE ABOVE 750V WILL BE MADE WITH METALLICALLY SHIELDED CABLE.

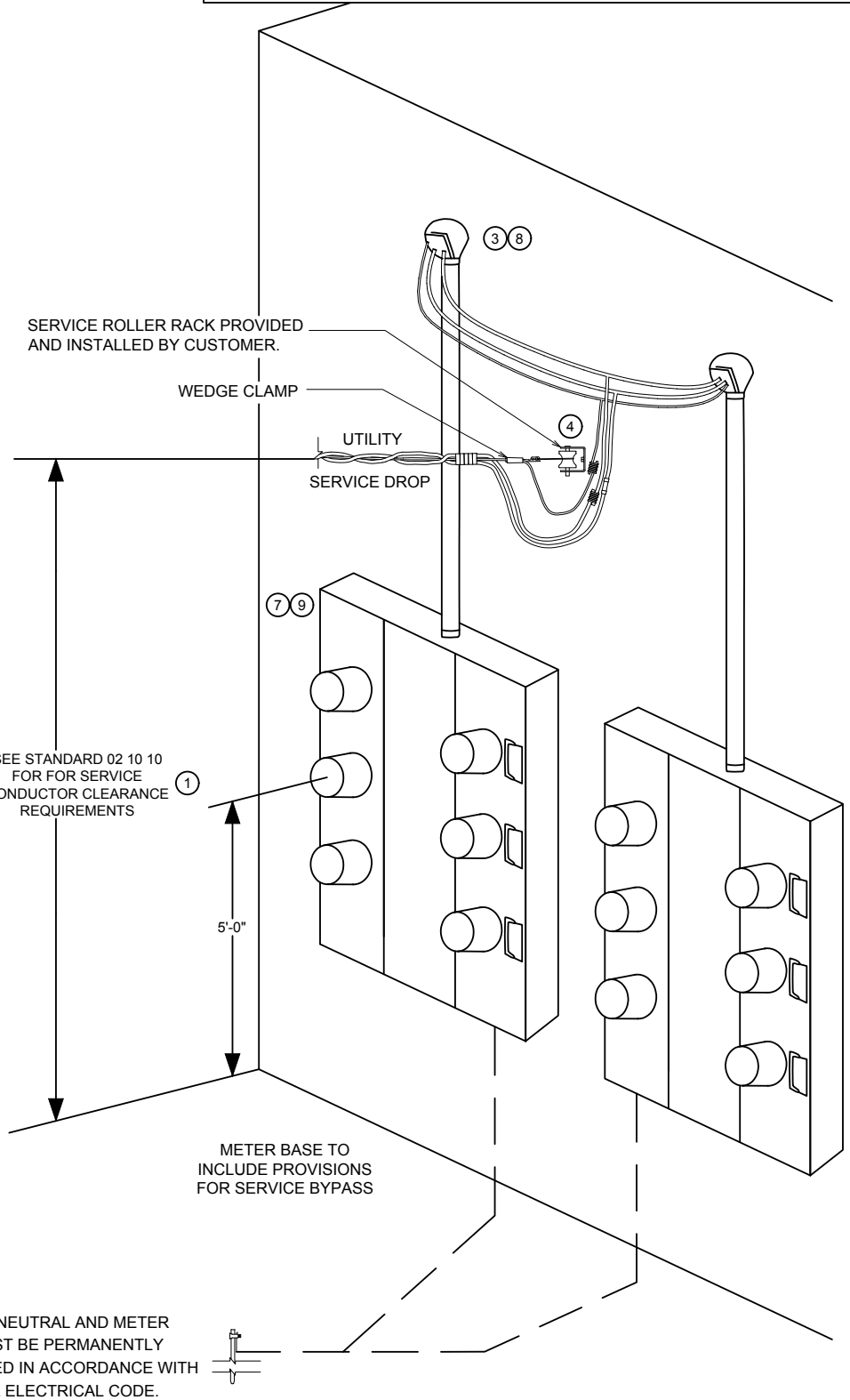

REQUIREMENTS FOR SERVICE

SERVICE CONNECTIONS CANNOT BE MADE UNTIL THE FOLLOWING CONDITIONS HAVE BEEN MET.

1. A RESPONSIBLE PERSON HAS APPLIED FOR SERVICE.
2. UTILITY HAS BEEN NOTIFIED BY THE APPROPRIATE INSPECTION AUTHORITY THAT THE INSTALLATION HAS BEEN INSPECTED AND APPROVED FOR SERVICE.
3. ALL UTILITY REQUIREMENTS FOR SERVICE HAVE BEEN MET AND THE INSTALLATION HAS BEEN ACCEPTED BY LOCAL UTILITY.

MATERIAL AND INSTALLATION

1. UTILITY WILL PROVIDE AND INSTALL THE ELECTRIC METER.
2. CONTRACTOR MUST INSTALL UTILITY APPROVED METER BASE OR APPROVED EQUAL. SEE APPROVAL LIST.
3. ALL OTHER MATERIAL IS TO BE FURNISHED AND INSTALLED BY THE CONTRACTOR IN CONFORMANCE WITH THE NATIONAL ELECTRIC CODE AND THE REQUIREMENTS OF THE INSPECTION AUTHORITY HAVING JURISDICTION.

SHOULD ANY OF THE CONDITIONS REQUIRED FOR SERVICE NOT BE MET, SERVICE WILL NOT BE CONNECTED AND THE UTILITY MAY IMPOSE AN APPROPRIATE CHARGE TO COVER THE COST TO RETURN AND CONNECT THE SERVICE.

THIS STANDARD DRAWING IS INTENDED TO PROVIDE A GUIDE FOR ONE OF VARIOUS ACCEPTABLE CONSTRUCTION DESIGNS. YOUR COMPANY REPRESENTATIVE WILL DETERMINE THE APPROPRIATE CONSTRUCTION DESIGN FOR YOUR SITUATION.

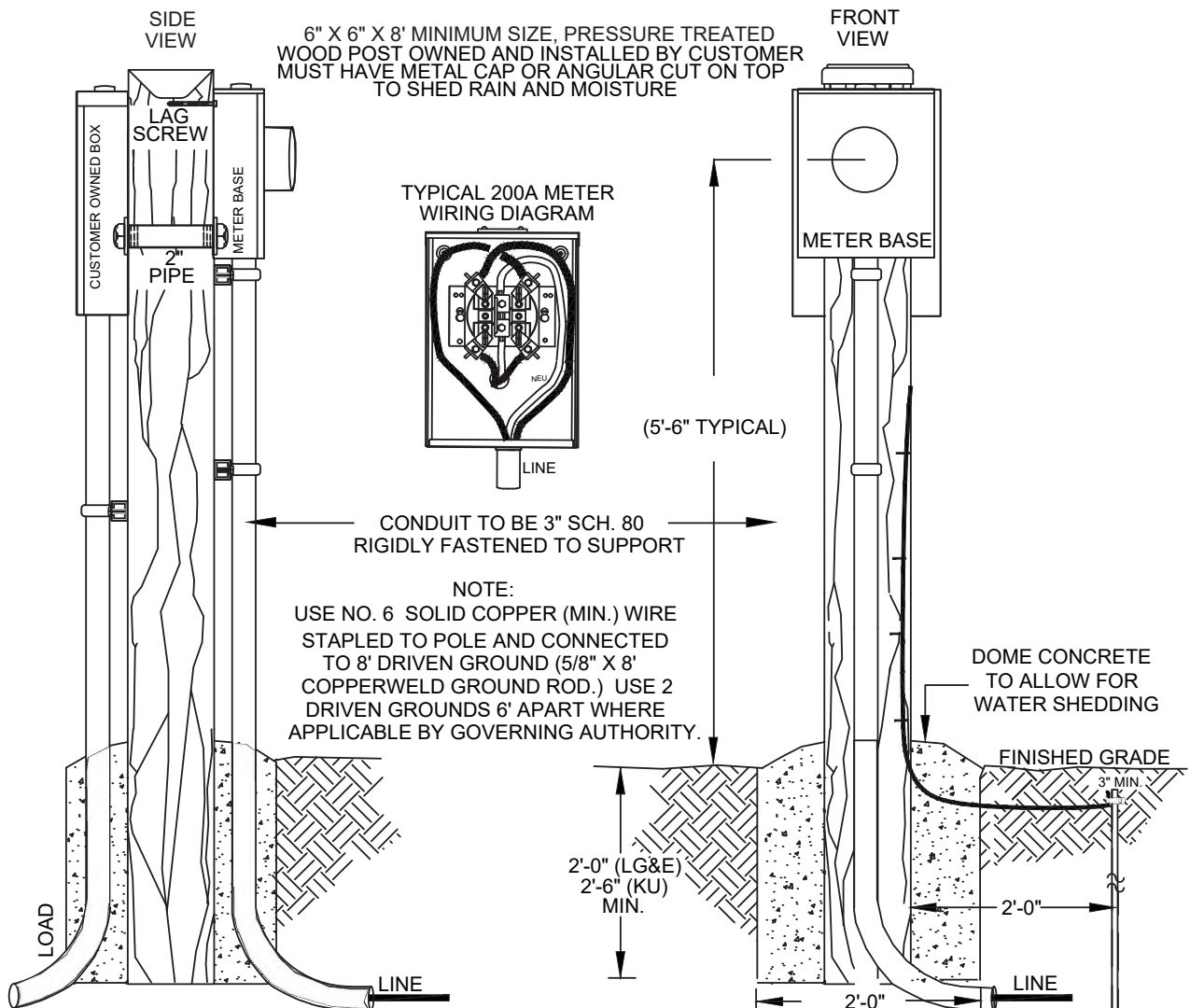

ALTERNATIVE CONSTRUCTION
(TYPICAL DOUBLE POST SUPPORT)

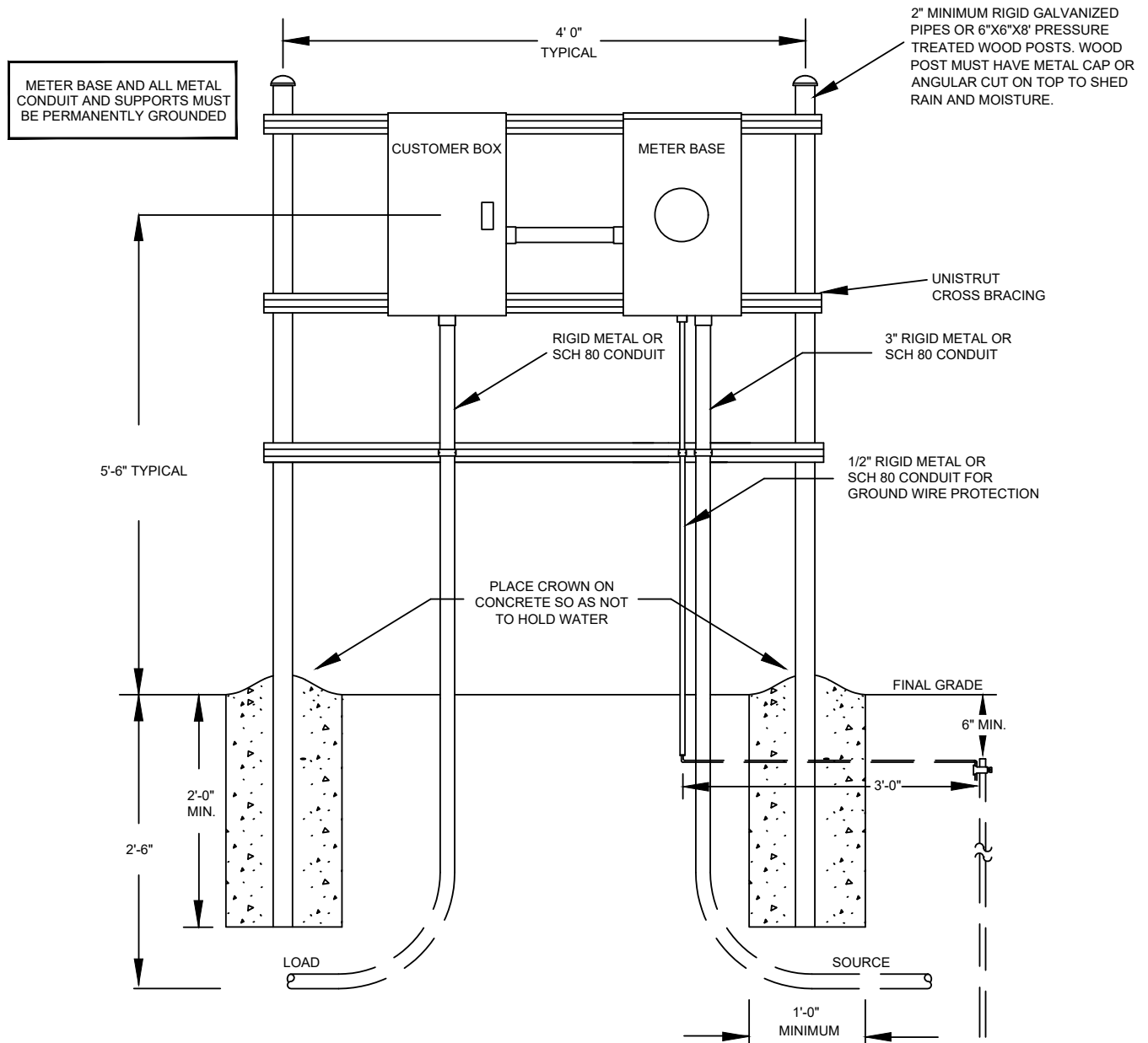

NOTE:

1. THE METER BASE SHOWN IS USED FOR BOTH SINGLE PHASE OVERHEAD AND SINGLE PHASE UNDERGROUND SERVICE.
2. A HUB FOR CONDUIT IS ATTACHED TO THE OVERHEAD METER BASE AT THE TOP. A PLATE IS SUBSTITUTED FOR THE HUB FOR ALL UNDERGROUND SERVICES.
3. TYPICALLY METER BASES ARE INSTALLED 5'-6" FROM CENTER OF METER TO FINISHED GRADE BELOW.
4. MAXIMUM WIRE SIZE FOR THIS 200A METER BASE IS 4/0 ALUM. OR 3/0 CU.
5. THE NEUTRAL USED IN THIS TYPE OF METER WILL BE INSULATED AND CONTINUOUS.
6. METER BASE PROVIDED BY CUSTOMER
7. METER BASES ARE TYPICALLY INSTALLED THREE WAYS.
 - A) TOGGLE BOLTS FOR CONCRETE BLOCK.
 - B) TAPCON SCREWS FOR BRICK MORTAR.
 - C) 2" WOOD SCREWS FOR VINYL SIDING OR WEATHERBOARDING.
8. METER BASE MUST HAVE BYPASS CAPABILITY

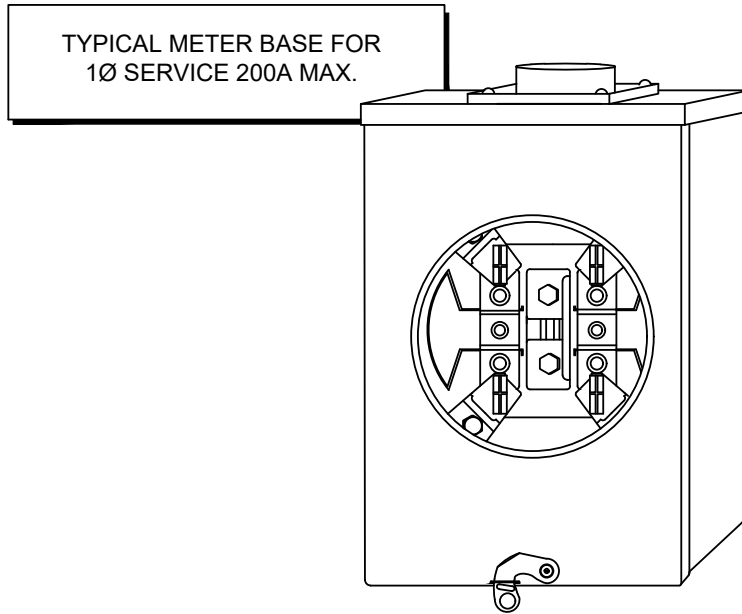

(COVER PLATE PROVIDED WITH BASE)

TYPICAL METER INSTALLATION FOR 1Ø OVERHEAD SERVICE (200A MAXIMUM)

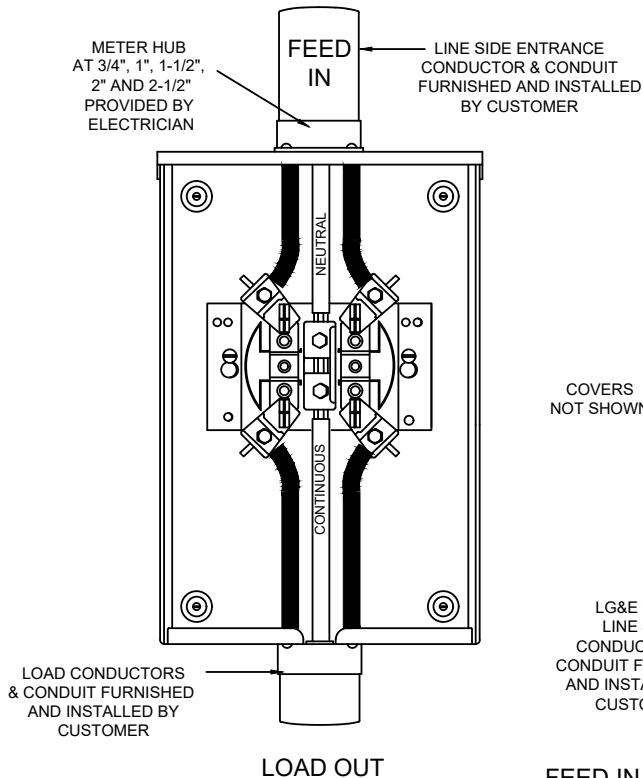

TYPICAL METER INSTALLATION FOR 1Ø UNDERGROUND SERVICE (200A MAXIMUM)

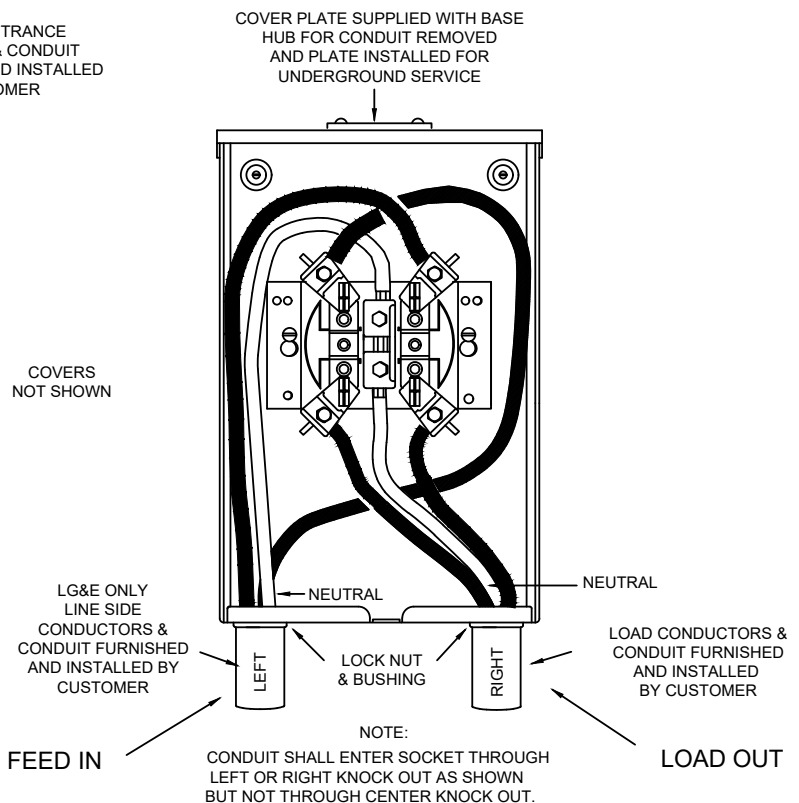

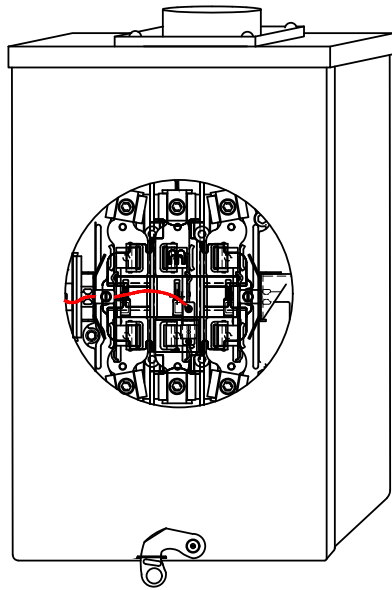

(COVER PLATE PROVIDED WITH BASE)

TYPICAL
SELF-CONTAINED/OVERHEAD METER
SOCKET FOR USE ON 4 WIRE 3Ø
SERVICES. ALL VOLTAGES
UP TO 400 AMP UNDER 300 VOLTS SERVICE

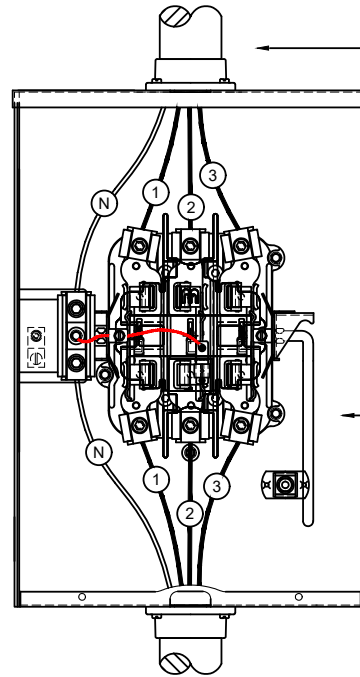

- LINE SIDE ENTRANCE
CONDUCTORS FURNISHED AND
INSTALLED BY CUSTOMER
- PLASTIC PROTECTIVE SHIELD
(NOT SHOWN) MUST BE IN
PLACE
- DELTA 4W HIGH PHASE MUST
BE ON RIGHT HAND SIDE
- BY-PASS LEVER
DO NOT OPERATE UNLESS
METER IS IN PLACE

CUSTOMER SUPPLIED BASES / MAXIMUM AMPS

- 120/240V - 400 AMPS MAX
- 240V DELTA - 120/240V DELTA - 400 AMPS MAX
- 277/480V - 200 AMPS MAX

TYPICAL
SELF-CONTAINED/UNDERGROUND METER
SOCKET FOR USE ON 4 WIRE 3Ø
SERVICES. ALL VOLTAGES
UP TO 400 AMP UNDER 300 VOLTS SERVICE

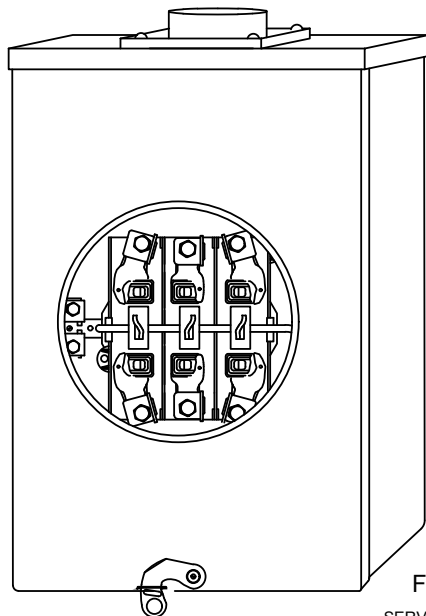

LOOP
FEED IN

SERVICE LATERAL
FURNISHED BY CUSTOMER

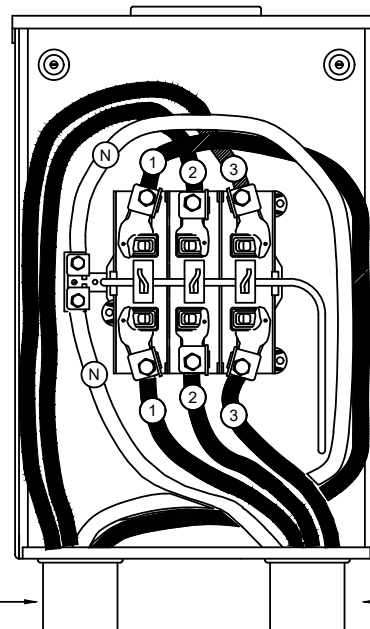

- DELTA 4W HIGH PHASE MUST
BE ON RIGHT HAND SIDE
- PLASTIC PROTECTIVE SHIELD
(NOT SHOWN)
MUST BE IN PLACE
- BY-PASS LEVER
DO NOT OPERATE UNLESS
METER IS IN PLACE

COVER
NOT SHOWN

LOAD OUT

LOAD CONDUCTORS FURNISHED
& INSTALLED BY CUSTOMER

NOTE:

CONDUIT SHALL ENTER SOCKET THROUGH LEFT OR RIGHT
KNOCKOUT BUT NOT THROUGH CENTER KNOCKOUT.

NOTE:

1. Load break disconnect switch is provided/installed by the customer.
2. Distance between meter base and disconnect to be a minimum of 6 inches and a maximum of 3 feet.
3. Meter base to be installed at a typical height of 5'-6" to the center of base above grade.
4. Disconnect to be installed on either side of meter base at the same level. Do NOT install disconnect directly above or below meter base except where approved by LG&E/KU.
5. Line side wires to be connected to top lugs of meter base and the disconnect switch.
6. Load side wires to be connected to bottom lugs of meter base and the disconnect switch.
7. Customer is responsible for the line side connection to the disconnect switch.
8. Customer is responsible for the connection between the load side of disconnect switch and the line side of the meter base.
9. Customer is responsible for the connection to the load side of the meter base.

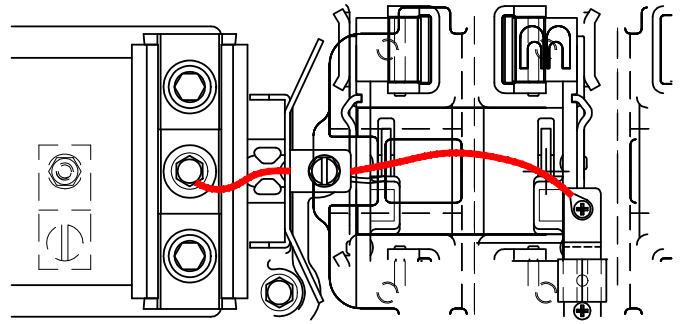

GROUNDING DETAIL

SWITCH REQUIREMENTS

1. Disconnect switch is to be purchased, installed and owned by the customer but will be locked or sealed and controlled by LG&E/KU.
2. Breakers and/or fused disconnects are not allowed.
3. Disconnect must provide a visible opening of the phases.
4. Disconnect must include a handle for operation that is lockable in the open and closed position.
5. Disconnect must be securable by a padlock.
6. Disconnect must be rated for the available fault current per the National Electric Code.

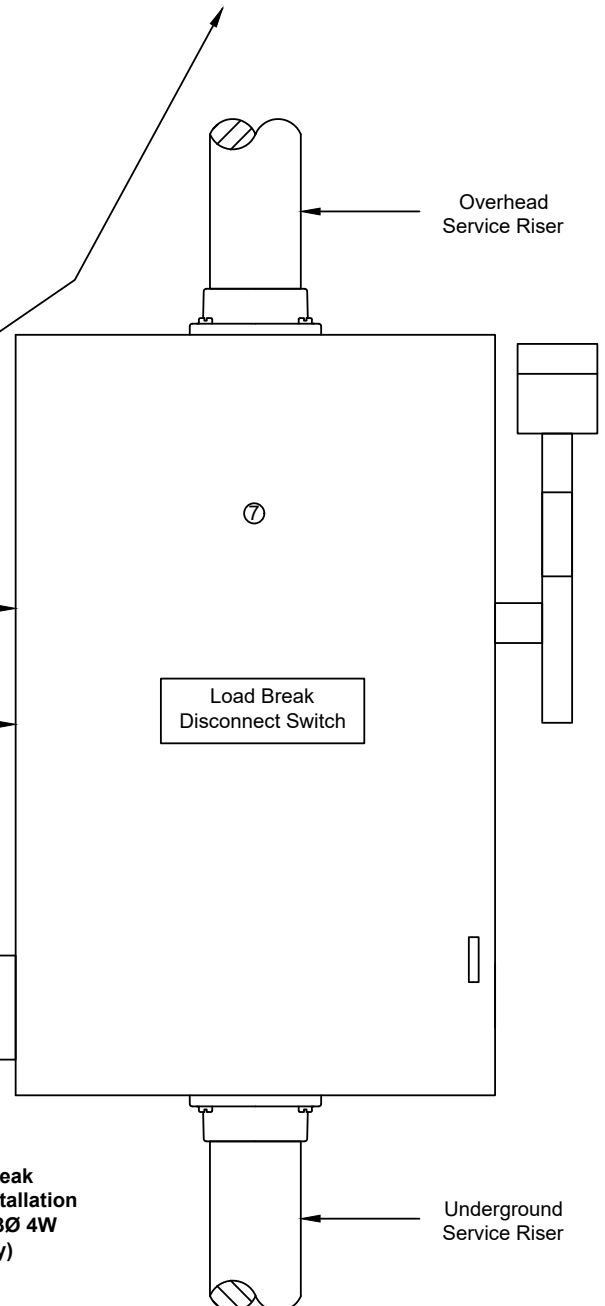
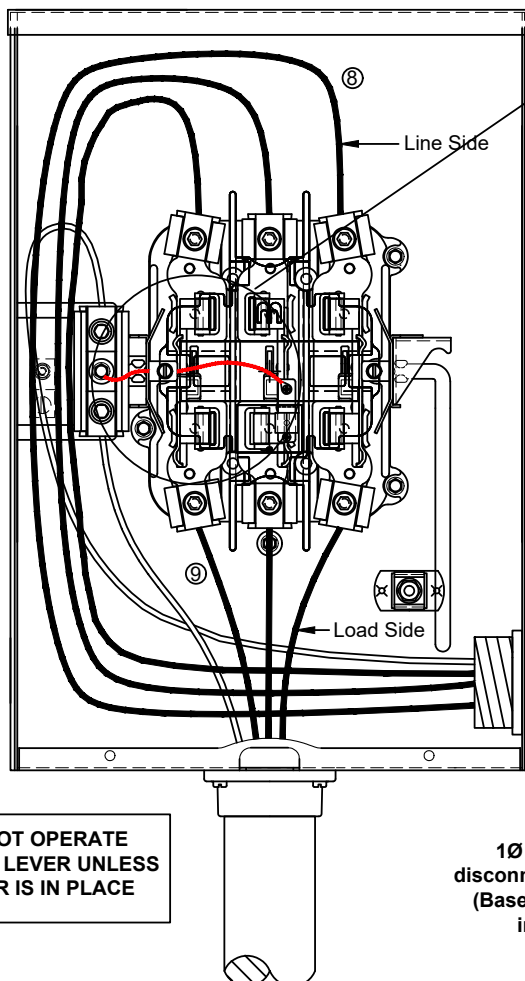

**DO NOT OPERATE
BYPASS LEVER UNLESS
METER IS IN PLACE**

**1Ø and 3Ø loadbreak
disconnect switch installation
(Base shown is for 3Ø 4W
installation only)**



Revised March 2025