

# PRODUCT MANUAL

## Blink Series 9 - Model 9030

Version 3.0



Blink™ Charging Station is a trademark of Blink Network, LLC. All other products or services mentioned are the trademarks, service marks, registered trademarks, or registered service marks of their respective owners.

Copyright ©2023 Blink Network, LLC. All rights reserved.

This material is protected by the copyright laws of the United States and other countries. It may not be modified, reproduced, or distributed without the prior, express written consent of Blink Network, LLC.

**1. Table of Contents**

1.	Table of Contents	2
2.	IMPORTANT SAFETY INSTRUCTIONS	5
3.	PRODUCT OVERVIEW	6
	<b>2.1 External View</b>	<b>7</b>
	<b>2.2 Internal View</b>	<b>8</b>
	<b>2.3 Features And Applications</b>	<b>9</b>
	<b>2.4 Specifications</b>	<b>10</b>
	<b>2.5 Dimensions</b>	<b>12</b>
4.	PLANNING AND DESIGN	13
	<b>Wireless Coverage</b>	<b>13</b>
	<b>3.1 Ventilation and Airflow</b>	<b>14</b>
	<b>3.2 AC Input Supply Requirements</b>	<b>15</b>
	<b>3.3 Grounding Requirements</b>	<b>15</b>
	<b>3.4 Tools Required</b>	<b>16</b>
4.	UNPACKING INSTRUCTIONS	16
	<b>4.1 Unpacking Precautions</b>	<b>16</b>
	<b>4.2 Packaging List</b>	<b>16</b>
	4.2.1 Head Unit.....	16
	4.2.2 Pedestal .....	18
	4.2.3 Wall mount.....	19
	<b>4.3 Unpacking</b>	<b>20</b>
	4.3.1 Unpacking Head Unit.....	20
	4.3.2 Unpacking Pedestal Unit .....	21
	4.3.3 Unpacking Wall Mount.....	22
5.	ASSEMBLY AND INSTALLATION INSTRUCTIONS	23
	<b>5.1 Assembly and Installation Precautions</b>	<b>23</b>
	<b>5.2 Ensuring Compliance with Local Codes and Regulations</b>	<b>23</b>
	<b>5.3 Installing Charger with Pedestal</b>	<b>24</b>
	5.3.1 Anchor Plate Installation .....	24
	5.3.2 Pedestal Assembly.....	27
	5.3.3 Attaching Pedestal to Anchor Plate.....	28

5.3.4	Holster Assembly .....	29
5.3.5	Head Unit Installation on Pedestal .....	29
5.3.6	Final Installation with Pedestal Mount.....	37
<b>5.4</b>	<b>Installing Charger with Wall Mount</b>	<b>38</b>
5.4.1	Wall Mount Installation.....	38
5.4.2	Head Unit Installation on Wall Mount.....	39
5.4.3	Final Installation with Wall Mount .....	44
<b>5.5</b>	<b>Connecting Input Power</b>	<b>45</b>
5.5.1	Connecting to Ac Input Power.....	46
6.	COMMISSIONING INSTRUCTIONS	48
<b>6.1</b>	<b>Commissioning Precautions</b>	<b>48</b>
<b>6.2</b>	<b>Pre-Commissioning</b>	<b>48</b>
6.2.1	Preparation.....	48
6.2.1	Enrollment.....	49
6.2.2	Configuration.....	49
<b>6.3</b>	<b>Activation</b>	<b>49</b>
<b>6.4</b>	<b>Powering The Charger</b>	<b>50</b>
6.4.1	Checklist Prior To Initial Power-Up.....	50
6.4.2	Initial Power-Up Sequence .....	50
6.4.3	System Initialization .....	51
6.4.4	Idle State.....	51
7.	OPERATING INSTRUCTIONS	53
<b>7.1</b>	<b>Operating Precautions</b>	<b>53</b>
<b>7.2</b>	<b>Operating the Charger</b>	<b>54</b>
7.2.1	User Authorization .....	54
7.3	System Charging .....	55
7.3.1	Charging Completed.....	56
<b>7.4</b>	<b>Operation Status</b>	<b>56</b>
<b>7.5</b>	<b>Use Of Emergency Button</b>	<b>57</b>
<b>7.6</b>	<b>Customer Support</b>	<b>57</b>
8.	MAINTENANCE INSTRUCTIONS	57
<b>8.1</b>	<b>Maintenance Precautions</b>	<b>57</b>

---

<b>8.2 Preventive Maintenance</b>	<b>58</b>
8.2.1 Checklist Before, During and After Maintenance .....	58
Before Maintenance .....	58
During Maintenance .....	58
After Maintenance .....	58
Cleaning .....	58
8.2.2 Replacing Filter .....	59
<b>8.3 Troubleshooting</b>	<b>60</b>
<b>8.4 Error Message or Codes</b>	<b>61</b>
<b>8.5 Limited Warranty</b>	<b>63</b>
8.5.1 Warranty Policy .....	63

## 2. IMPORTANT SAFETY INSTRUCTIONS

This document provides instructions to assemble, install, operate, and maintain the DCFC 30kW – Model 9030 Charging Station and should not be used for any other products. This product must be installed in accordance with the National Electrical Code (NEC), the Canadian Electrical Code (CEC) or any applicable local code.

Review this manual and consult a licensed contractor and/or electrician before installation to ensure compliance with local building practices, climate conditions, safety standards, and state and local codes.

The Charging Station should be installed by a licensed contractor/ electrician and inspected by a qualified installer before initial use. Under no circumstances will compliance with the information in this manual relieve the user of responsibility to comply with all applicable codes and safety standards.

This document describes the most common assembly, installation, operations, and maintenance methods. Contact Blink where it is not possible to assemble, install, operate, or maintain using the procedures provided in this document.

The following signs are used on the equipment and on in this manual following ANSI Z535 standard.

#	Signs	Intended Use
1		Situation will result in severe injury or death
2		Situation could result in severe injury or death
3		Situation could result moderate or minor injury
4		Situations that at worst will only result in property damage and will not result in physical injuries

**▲ DANGER** Make sure to TURN OFF the breakers before doing any electrical work! This document is not offered as a formal design document. All designs for the installation of this product are the sole responsibility of the appropriately licensed and/or certified installing contractor.

**▲ WARNING** Blink is not responsible for damage that may occur or result from installations that are not described in this document. Reasonable effort has been made to ensure that the specifications and other information in this manual are accurate and complete at the time of publication. However, this manual's specifications and other information are subject to change at any time without notice.

**▲ CAUTION** SAVE THESE INSTRUCTIONS  
This manual contains important instructions for DC (Direct Current) Charger Model 9030

**NOTICE** IN NO EVENT SHALL BLINK OR ITS AUTHORIZED DISTRIBUTORS BE LIABLE FOR ANY INDIRECT, INCIDENTAL, SPECIAL, PUNITIVE, OR CONSEQUENTIAL DAMAGES, INCLUDING WITHOUT LIMITATION, LOST PROFITS, LOST DATA, LOSS OF USE, COST OF COVER, OR LOSS OR DAMAGE TO THE BLINK CHARGING STATION ARISING OUT OF OR RELATING TO THE USE OR INABILITY TO USE THIS MANUAL, OR RELATED PRODUCT, EVEN IF BLINK OR ITS AUTHORIZED

---

**DISTRIBUTORS HAVE BEEN ADVISED OF THE POSSIBILITY OF SUCH DAMAGES.**

All products or services mentioned are the trademarks, service marks, registered trademarks, or registered service marks of their respective owners. This material is protected by the copyright laws of the United States and other countries. It may not be modified, reproduced, or distributed without the prior, express written consent of Blink Network, LLC.

### **3. PRODUCT OVERVIEW**

The Series 9 30kW DC Fast Charger is the top choice to power battery electric vehicles (BEV) and plug-in electric vehicles (PHEV (Plug in Hybrid Electric Vehicle)). It is designed for quick charging in both public and private locations, such as retail and commercial parking spaces, fleet charging stations, highway service areas, workplace, residence, etc.

The Series 9 DC Fast Charger has the advantage of easy installation. The pedestal mounted design realizes flexible and cost-effective installation for several types of locations. The DC charger also has network communication capability. It can connect with the Blink network platform and provide drivers of electric cars with real-time information, such as the location of charging stations, charging progress, and billing information. The 30kW DC Fast Charger has a user interface with function buttons, safety certifications, and a Type 3R enclosure suitable for outdoor environments.

### 3.1 External View

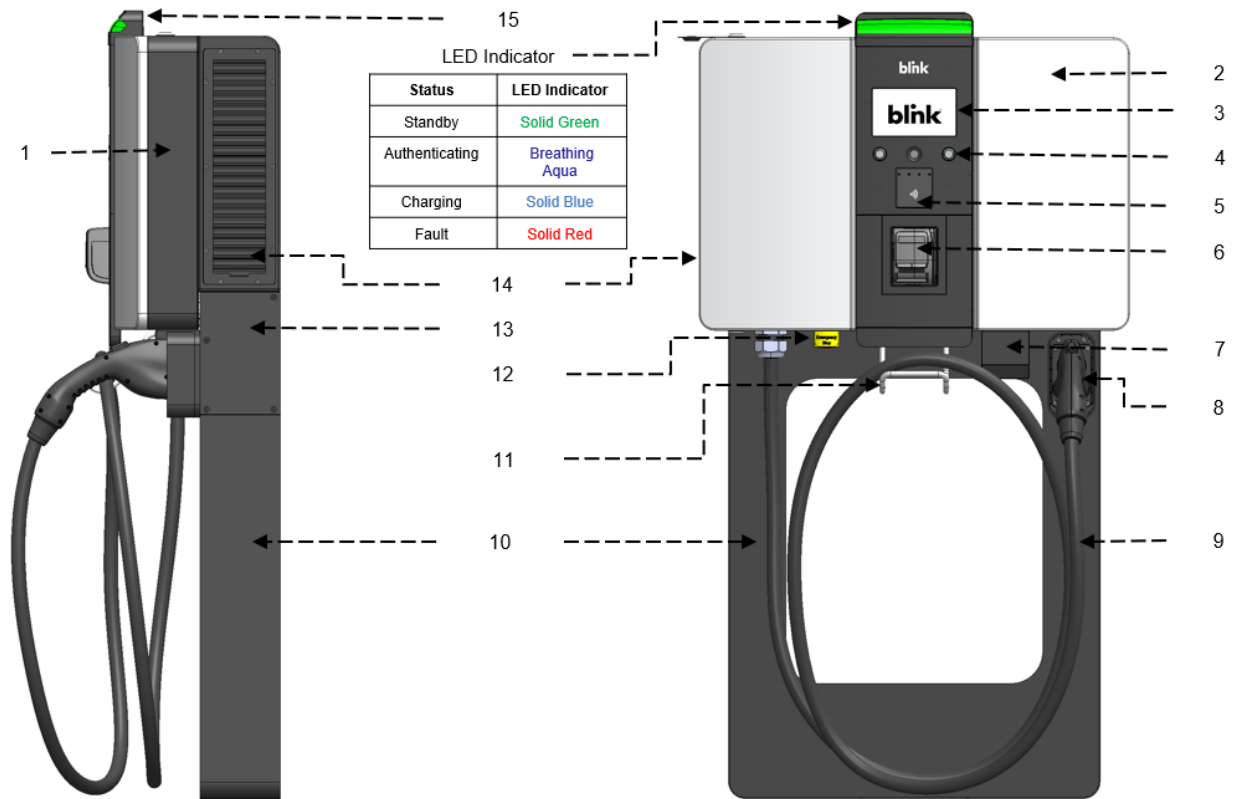

Fig. 1 – External View

- 1 – Rear Enclosure
- 2 – Front Enclosure
- 3 – Display/Screen 7" Inch
- 4 – Camera & Control Buttons
- 5 – RFID Reader
- 6 – Credit Card Reader
- 7 – Ethernet Connection
- 8 – Holster / CCS1 DCFC Cord Mount
- 9 – DC Charging Cable
- 10 – Pedestal
- 11 – Cable Hanger
- 12 – Emergency Stop Button
- 13 – Side Access Plate
- 14 – Vent (Inlet & Outlet)
- 15 – LED Assembly

### 3.2 Internal View

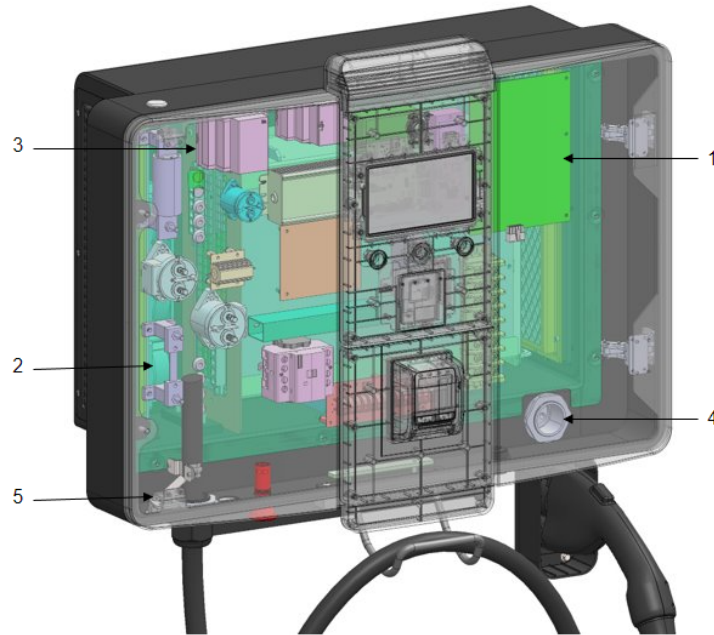

Fig. 2 – Internal View

- 1 – Power Board
- 2 – External Fan
- 3 – IMD
- 4 – AC Power Input
- 5 – Cable Gland for DC Output



### 3.3 Features And Applications

High-level features:

- Pedestal or Wall-Mounted design makes installation easy and flexible.
- Offers customers the convenience of start/stop charging control from an authorized RFID smart card or mobile APP or credit card. Note: Credit card reader is optional.
- Built on latest industry standards for DC charging.
- Cellular 4G LTE, Wi-Fi, and Ethernet Connection.
- Robust, all-weather protection to prevent damage from nature and natural elements.
- Compact footprint with pedestal mount.
- 7-inch LCD daylight readable touchscreen.
- User Friendly Interface.
- ISO15118 based Plug and Charge, NFC (Near Field Communication) and RFID authentication enabled.
- Various payment options, including Credit cards, Apple pay, and Google pay.
- Smart charging, remote access, diagnostics, and Over-the-Air (OTA) software update enabled.
- Charge all electric or plug-in hybrid electric vehicles, including medium- and heavy-duty trucks and buses.
- OCPP (Open Charge Point Protocol) 1.6 enabled and upgradable to future versions
- Optional Fleet Management Software Module delivers powerful capabilities to help you configure, track, and manage your fleet.

Applications of the charger:

- Commercial
- Retail with optional credit card reader
- Fleet
- Dealership
- Highway rest areas

### 3.4 Specifications

Electrical Specification – DC Output	
Number of Ports	One
Power	30 kW Max
Current	60A Max @ 150 ~ 500 VDC; 30A Max @ 1000 VDC
Voltage	150 ~ 1000 VDC
Charging Connector	CCS1
Charging Interface	DIN 70121, ISO 15118
Electrical Specification – AC Input	
Power	32 kVA Max
Current	3-phase: 38A Max
Voltage	277/480V (3P + N + PE)
Frequency	50/60 Hz
Power factor	> 0.98
Safety Specification	
Input Protection	Over/under voltage, over current, overpower, over temperature, surge protection and ground fault detection
Output protection	Over/under voltage, over-current, over temperature, short-circuit protection and insulation monitoring device
Internal protection	Over temperature protection, AC contactor monitoring, DC contactors monitoring, filter clog detection (coming soon)
Surge Protection	6kV/3000A
Network Specification	
Data Communication	Cellular 4G LTE, Wi-Fi, Ethernet
Charging Infrastructure Communication	OCPP 1.6J Compliant
Remote Management	Remote access, diagnostics, Over-the-Air (OTA) software update enabled
Load Management	Smart, dynamic allocation and distribution of power to EVSEs
User Interaction Specification	
Charging Status Indicator	High visibility, multi-color LED visual status indication
Display	7" LCD daylight readable touch screen (touch functionality coming soon)
RFID Authentication	RFID: ISO 14443 Type A & B, MiFare, Felica, ISO 15693
NFC Authentication	NFC: Apple VAS, NEMA, Google Smart Tap (coming soon) ==

	Plug and Charge: ISO 15118
Payment	Optional: Apple/Google Pay, Contactless/Magnetic/EMV Credit Card
Emergency stop button	One for the Charger
<b>Environmental Specification</b>	
Enclosure	NEMA 3R outdoor rated
Operating Humidity	Up to 95% non-condensing
Operating Temperature	-25° C (-13° F) to +50° C (122° F);
Operating Altitude	<=6560 ft
Cooling Method	Forced air
<b>Mechanical Specification</b>	
Dimensions	w/cc reader 24.7" H x 31.9" W x 14.6" D; w/o cc reader 24.7" H x 31.9" W x 12.8" D
Approximate Weights	Device: w/cc reader 158.7 lbs.; w/o cc reader 158.0 lbs. Pedestal mount: 103.6 lbs. Wall mount bracket: 35.27 lbs.
Mounting Option	Wall and Pedestal mount
Cable length	16 ft standard, 23ft optional
Cable organizer	Integrated
<b>Regulation</b>	
Safety	UL 2202 / CSA C22.2 No. 107.1-16, UL 2231-1 / CSA C22.2 No. 281.1-12, UL 2231-2 / CSA C22.2 No. 281.2-12 certified
EMI	FCC Part 15 Class A compliant
Energy Efficiency	Energy Star compliant
Weights and Measurements	California Type Evaluation Program (CTEP) certified
Accessibility	ADA compliant

### 3.5 Dimensions

Charger Dimensions:

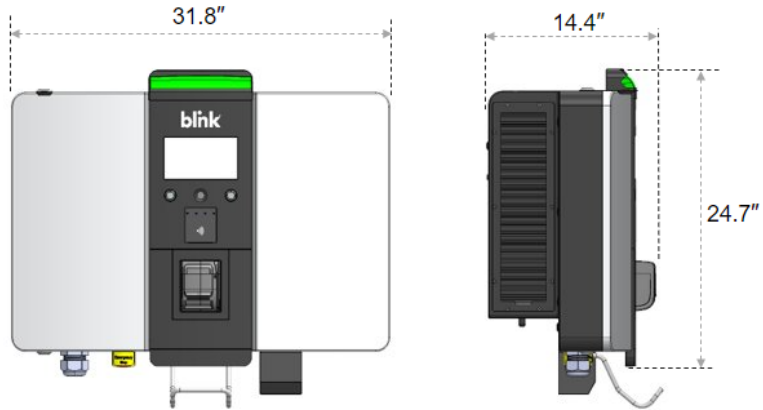

Fig. 3 – Charger Dimensions

Pedestal Dimensions:

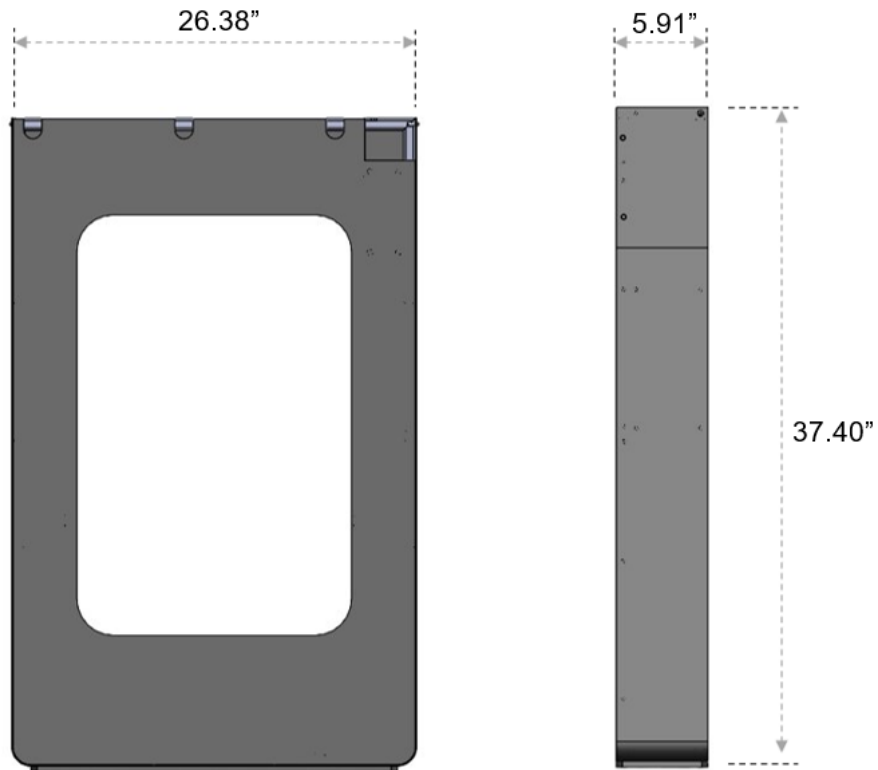

Fig. 4 – Pedestal Dimensions

Pedestal Anchor Plate Dimensions:

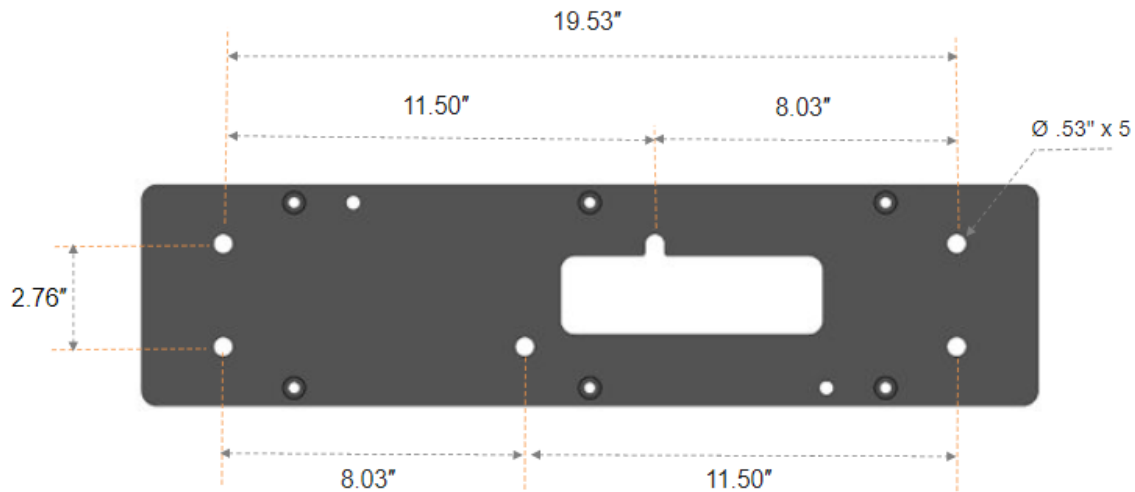

Fig. 5 – Pedestal Anchor Plate Dimensions

### 4. PLANNING AND DESIGN

#### Wireless Coverage

- **CAUTION** The equipment generates, uses, and can radiate radio frequency energy and, if not installed and used in accordance with the instruction manual, may cause harmful interference to radio communications.
- **NOTICE** This equipment has been tested and found to comply with the limits for a Class A digital device, pursuant to Part 15 of the FCC rules. These limits are designed to provide reasonable protection against harmful interference when the equipment is operated in a commercial environment.
- It is recommended to test Wi-Fi and 4G signal strength before charger installation. The RSSI (Received Signal Strength Indication) value should be higher than -65dBm. Poor connection quality might interrupt charging process or data transaction.

Verizon	4G LTE	Band 13 Band 4	RSRP: -95 dBm RSRQ: -13 dB
ATT or T-Mobile	4G LTE	Band 2 Band 4 Band 5 Band 12 Band 13	RSRP: -95 dBm RSRQ: -13 dB

Table 1 – Cellular Carriers and Bands

## 4.1 Ventilation and Airflow

The DC Fast Charger is cooled by forced air. Please keep the charger in a ventilated location and do not block the air vents of the DC Fast Charger.

The following diagram shows the ventilation and airflow of the charger. The charger needs to be installed accordingly.

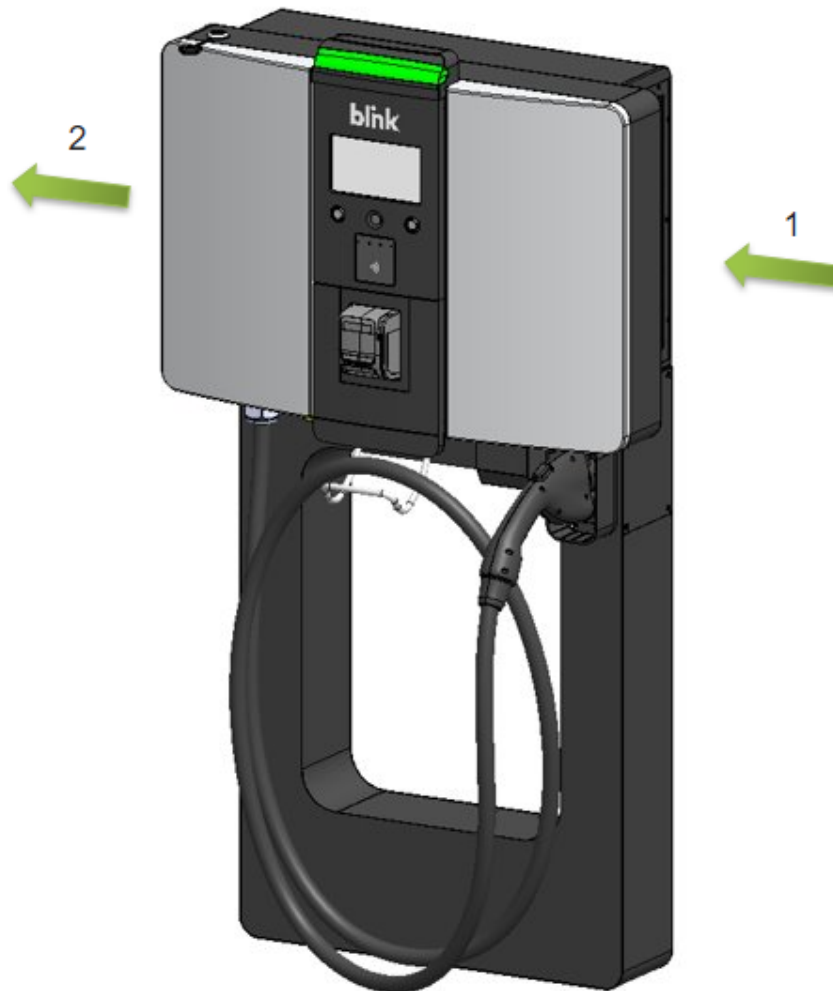

Fig. 6 – Direction of Ventilation Airflow

5. Air Inlet
6. Air Outlet

- ▲WARNING** The product should be installed with at least 24 inches of unobstructed clearance distance to all air ventilation.
- ▲WARNING** Sufficient space is needed for product installation, maintenance, and

ventilation. Please keep not less than 60cm (about 1.97 ft) clearance distance from both sides and front panel.

## 4.2 AC Input Supply Requirements

- ❑ The power source must be a 277/480V 3 Phase Wye electrical system.
- ❑ The electrical capacity must be at least 32.0 kVA to function correctly.
- ❑ The Series 9 30kW DC Fast charger must be fed from a 50 A four pole, common trip circuit breaker.
- ❑ The Series 9 30kW DC Fast charger has an internal 20 mA GFCI circuit, therefore GFCI breakers are not needed unless required by local electrical code.
- ❑ A four pole 63A 480V-AC disconnect switch must be installed in accordance with the National Electric Code, ANSI/NFPA 70.

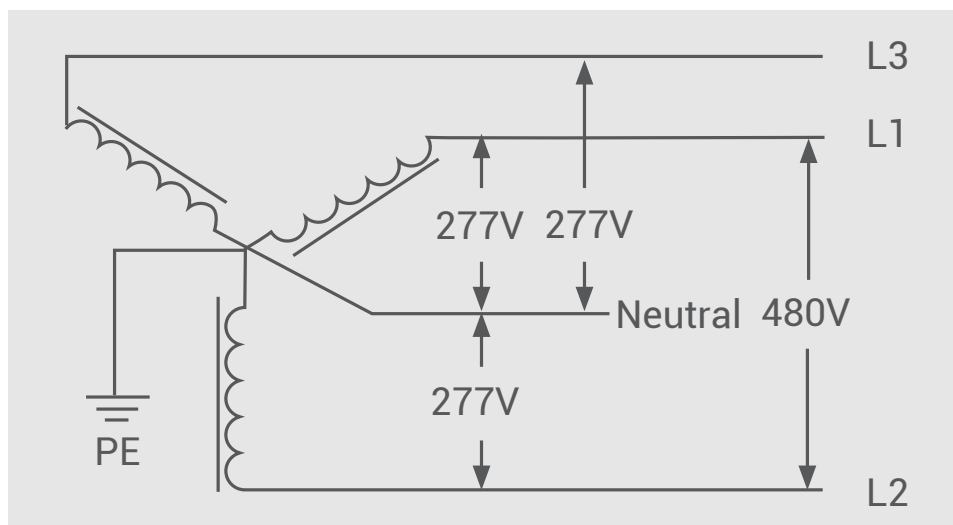

Fig. 7 – 480V Three-Phase Wiring Connection

## 4.3 Grounding Requirements

- ❑ The electrical system must have a complete grounding system, including a main bonding jumper in compliance with all applicable electrical codes.
- ❑ This is fed from a Wye-connection power grid, the Series 9 30kW DC Fast Charger must connect to L1, L2, L3, Neutral, and Ground. Earth ground must be connected to neutral at only one point, normally at the service entrance to the building.
- ❑ Earth Connection is Essential!
- ❑ The Charging Station is grounded through a dedicated conductor to the ground connection at the power distribution panel. The product must be connected to a grounded, metal, permanent wiring system. Connections shall comply with all applicable electrical codes.
- ❑ **⚠ DANGER** Blink EV (Electric Vehicle) charging stations require a solidly grounded electrical system with the presence of a main bonding jumper or system bonding jumper. Ungrounded sources or impedance grounded sources of any type (resistor/reactor) are not suitable for Blink EV charging stations.

## 4.4 Tools Required

Tools required for installation and maintenance (**Note: Does not include tools required for installation of electrical conduit**)

Tool	Notes
Metric Allen Keys (2.5mm, 3mm, 4mm, 5mm, 6mm)	2.5mm only required for air filter replacement
SAE Allen Key (1/4")	Required for pedestal installation only
Right angle driver with 5mm hex bit	(Optional) for pedestal installation
3/4" socket or box wrench	
Wire Stripping tool	For 6 AWG and 8 AWG
Wire Crimping tool	For 6 AWG and 8 AWG non-insulated ring terminals
5/8" masonry drill bit/driver	Required for wall mount installation only
PH3 Philips Screwdriver	Required for Wiring Input AC cables to the Terminal Block

Table 2 – Tools Required

## 4. UNPACKING INSTRUCTIONS

### 4.1 Unpacking Precautions

- **▲ CAUTION** The instructions given for the unpacking are to be carefully followed to avoid any injury or damage to the device and powder coating and painting surfaces.
- **▲ CAUTION** Careful if dismantling any mechanical parts related to hardware items which may cause damage to the cable.

### 4.2 Packaging List

The unit is shipped in two packages as shown below: 1) Head unit and 2) Pedestal unit.

#### 4.2.1 Head Unit





Fig. 8 – Head Unit Box Contents

- 1 – Accessories Box
- 2 – Head Unit

### 4.2.2 Pedestal



Fig. 9 – Pedestal Box Contents

- 1 – Accessories Box
- 2 – Pedestal Unit
- 3 – Anchor Plate Assembly
- 4 – Holster Assembly

### 4.2.3 Wall mount



Fig. 10 – Wall Mount Box Contents

- 1 – Accessories Box
- 2 – Wall Mount Structure
- 3 – Wall Mount Bracket
- 4 – Conduit Cover
- 5 – Holster Assembly

## 4.3 Unpacking

### 4.3.1 Unpacking Head Unit

Unpack the head unit as shown in the diagram below.

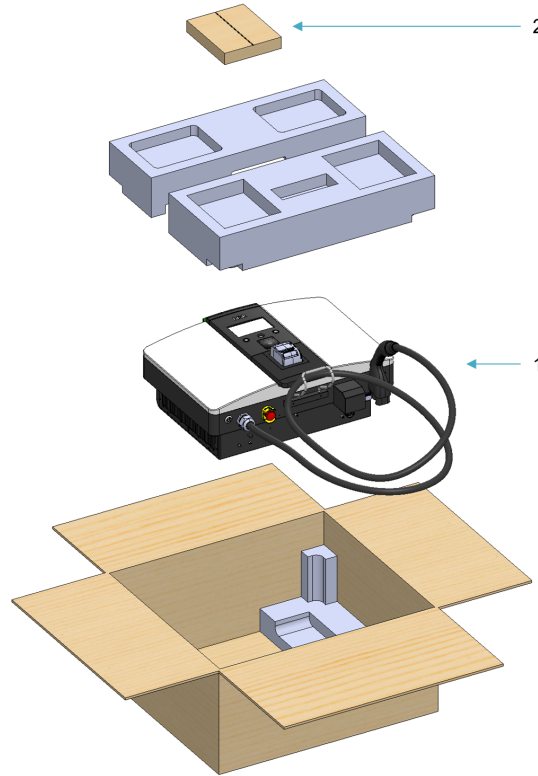

Fig. 11 – Unpacking Head Unit Box

- ❑ **CAUTION** The charger weight is 60 kg (132 lbs.)! Be careful during the time of lifting the head unit out of the box.
- ❑ **NOTICE** We recommend two people to lift the head unit.

Please make sure that the head unit box contains the following items.

1. Head Unit
2. Accessories Box contains the below components:

Item	Quantity
Enclosure locking key (8mm)	2
M6 x 25mm Allen Cap Screw + Spring Washer	8
Ferrite Core for Input Wiring	1
#6 AWG Ring Terminal Connectors for M6 Stud	4
#6 AWG Ring Terminal Connector for M5 Stud	1
Heat Shrink Tube (12.7mm)	16 cm
Nylon Cable Tie	2

Table 3 – Head Unit Accessories Box contents

### 4.3.2 Unpacking Pedestal Unit

Unpack the pedestal unit as show in the diagram below:

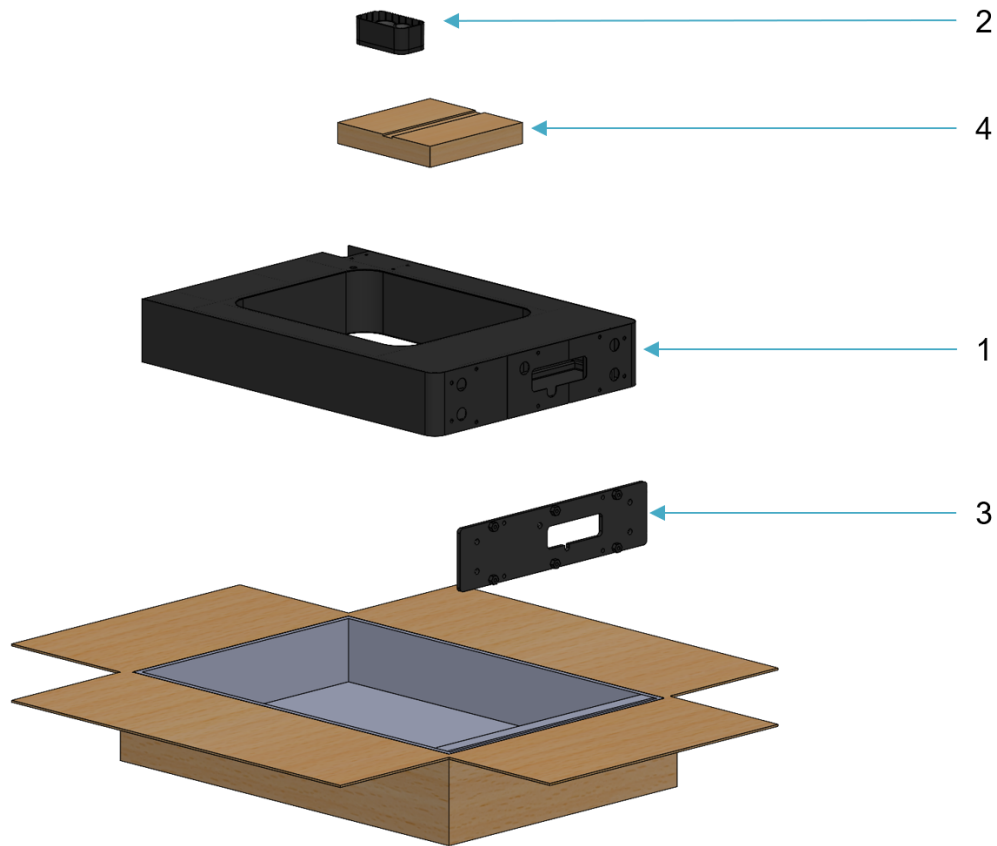

Fig. 12 – Unpacking Pedestal Box

Please make sure that the box contains the following items.

1. Pedestal
2. Holster Assembly
3. Anchor Plate
4. Accessories Box contains the below components:

Item	Quantity
M6 x 30mm Button Head Screw + Spring Washer	4
J-Bolts with Nut and Washer (1/2"-13 x 10")	6
5/16"-18 x 1-3/4" Socket Cap Screw, Stainless Steel	6
5/16" High Collar Lock Washer, Stainless Steel	6
5/16"-18 x 1-1/4" Socket Cap Screw, Galvanized (Sacrificial Bolts)	6

Table 4 – Pedestal Accessories Box contents

### 4.3.3 Unpacking Wall Mount

Unpack the Wall Mount unit as show in the Steps below:

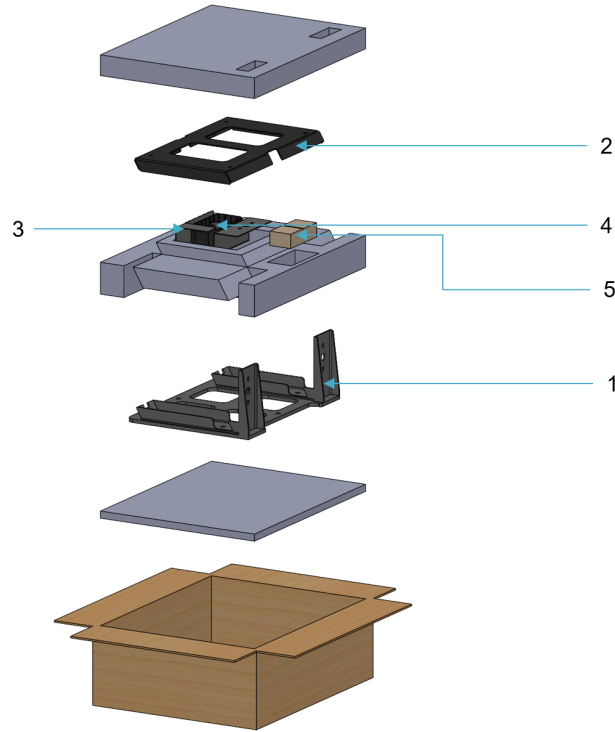

Fig. 13 – Unpacking Wall Mount Box

Please make sure that the box contains the following items.

1. Wall Mount Full Assembly
2. Wall Mount Bracket
3. Conduit Cover
4. Wall Mount Structure
5. Holster Assembly
6. Accessories Box contains the below components.

Item	Quantity
M6 x 20mm Allen Cap Screw + Spring Washer	4
1/2"-13 x 5-1/2" Stud Anchors, Stainless Steel	6

Table 5 – Wall Mount Accessories Box contents

## 5. ASSEMBLY AND INSTALLATION INSTRUCTIONS

Read all the instructions before using and installing this product.

### 5.1 Assembly and Installation Precautions

- **⚠ CAUTION** Follow the instructions given for the installation to avoid any injury or damage to the device.
- **⚠ CAUTION** The product should be installed only by a licensed contractor and/or licensed technician in accordance with all building codes, national / local electrical codes, and safety standards. For installation in Canada, the installation shall be in accordance with the Canadian Electrical Code, Part I.
- **⚠ CAUTION** TURN OFF the circuit breakers before doing any electrical work!
- **⚠ CAUTION** Verify input power is de-energized and “locked out” at Circuit Breaker panel when installing, servicing, or maintaining the charger.
- **⚠ CAUTION** Use appropriate personal protective equipment when connecting to the main power distribution network.
- **⚠ CAUTION** Always connect the Protective Earth (PE) first, before connecting the other power input wires.
- **📌 NOTICE** Perform a voltage check to ensure electrical power is disconnected from the system
- **📌 NOTICE** Use appropriate tools for each task.
- Chassis Plate mounting screws torque must not be increased above 3 Nm.
- Air vent sub assembly torque value must not be increased above 3-4 Nm.

### 5.2 Ensuring Compliance with Local Codes and Regulations

The below picture shows the height of the operable parts and Push button from the top and bottom of the charger. It is the installer's responsibility to use this information to define the height at which to install the Model 9030 DC30 charger from the ground and ensure compliance with local codes and regulations (for example, ADA Requirements in the USA)

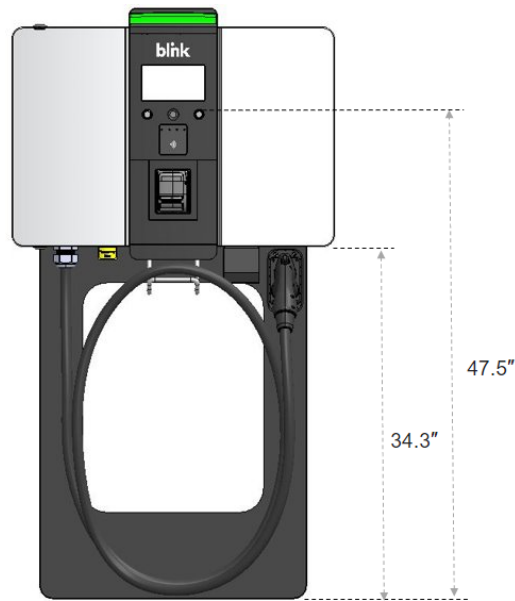

Fig. 14 – Charger on Pedestal Dimensions

## 5.3 Installing Charger with Pedestal

### 5.3.1 Anchor Plate Installation

The anchor plate must be installed on a freshly poured concrete pad, with the wiring conduit emerging through the rectangular opening in the anchor plate (maximum conduit diameter 1.5").

- Ensure that at least 54" of wire extends out of the conduit.
- The side of the anchor plate with (6) welded nuts should face downwards.
- Install (6) 5/16" x 1 1/4" Sacrificial bolts into the welded nuts. (These will be removed after the concrete is set).
- Install (6) J-bolts into the holes in the anchor plate as shown.
- Insert the anchor plate into the concrete immediately after pouring the concrete.
- It is recommended to vibrate the concrete to remove any air bubbles.
- The anchor plate should be installed level with the ground.



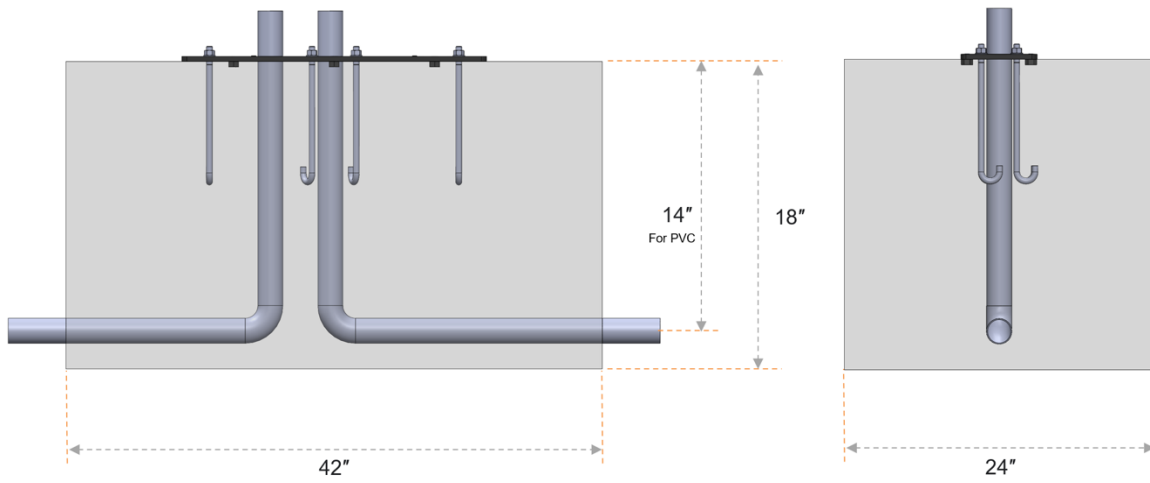

Fig. 15 – Concrete Pad Dimensions

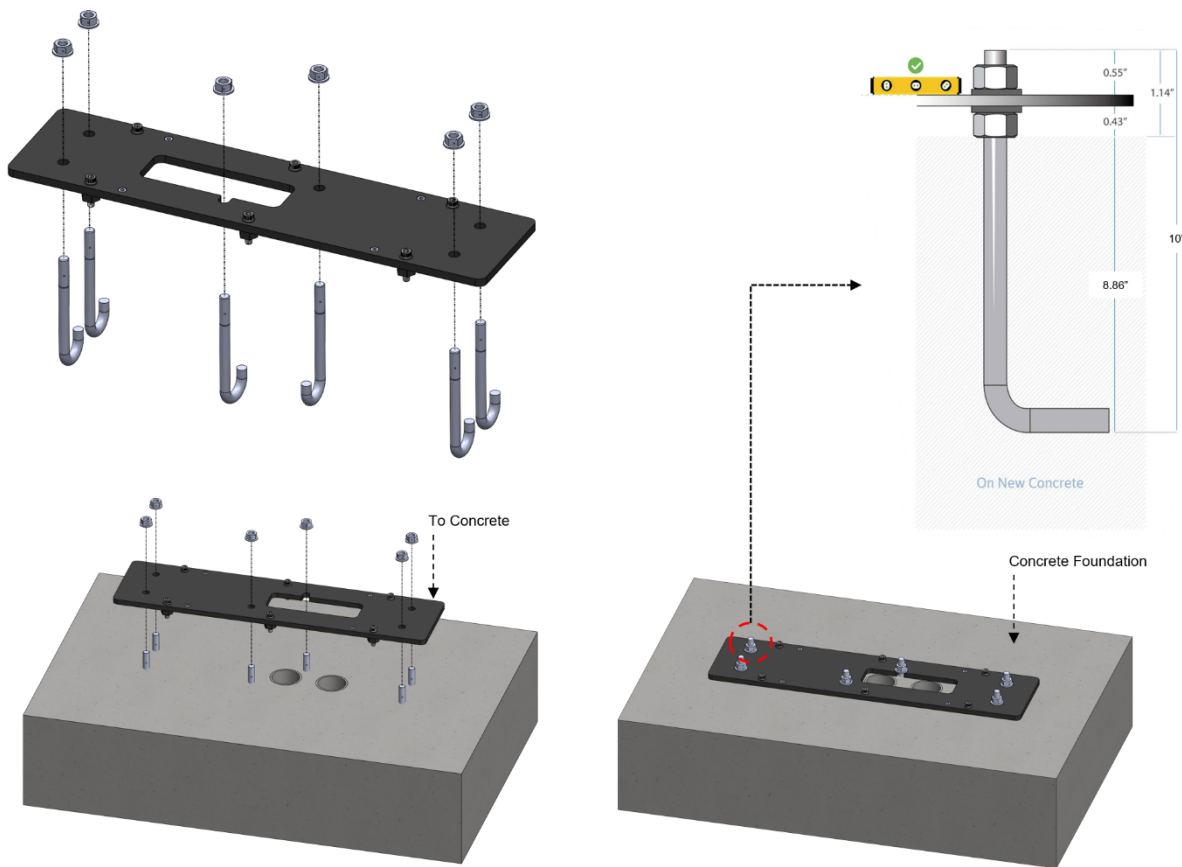

Fig. 16 – Anchor Plate Mounting

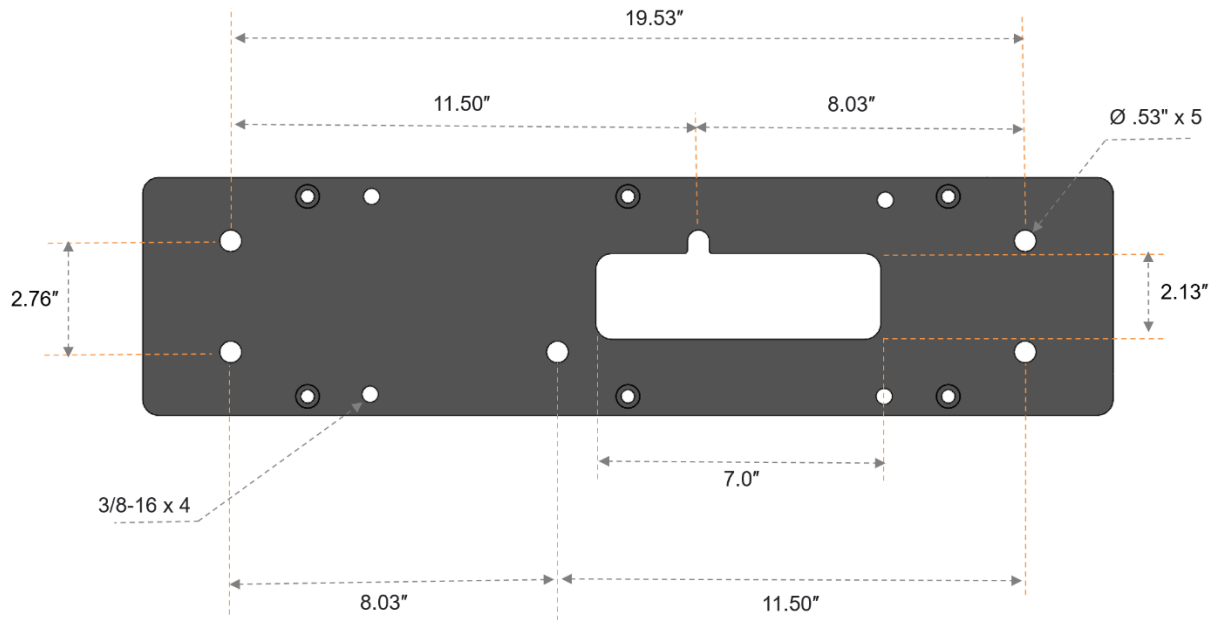

Fig. 17 – Anchor Plate Hole Dimensions

Refer to above anchor hole dimensions for anchor plate installation.

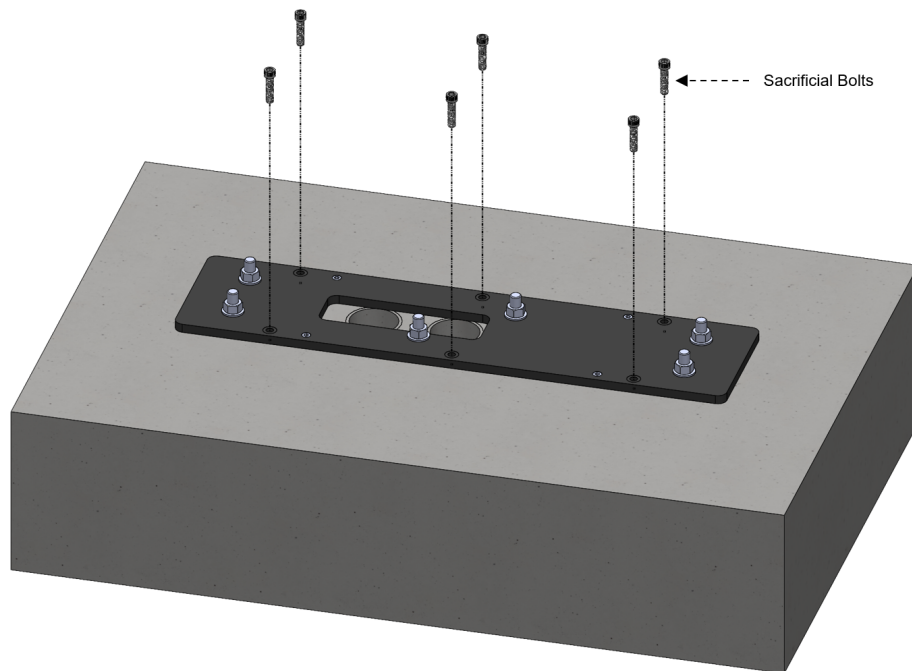

Fig. 18 – Sacrificial Bolts

Take out the Sacrificial Bolts once the concrete is set.

### 5.3.2 Pedestal Assembly

Follow the diagram below to assemble the pedestal unit:

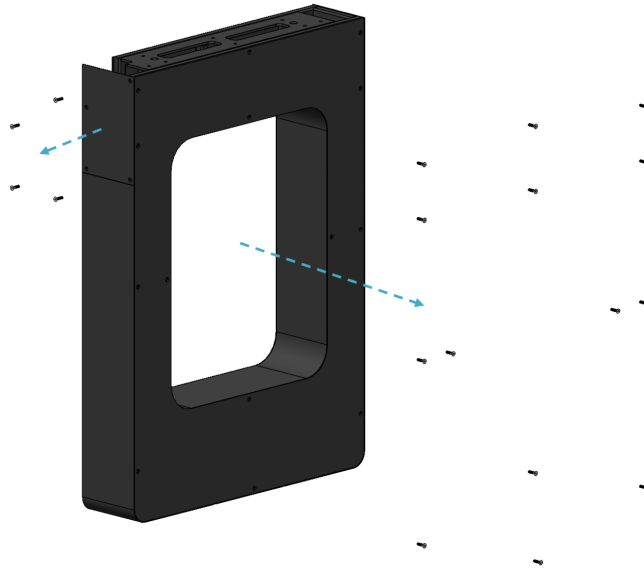

Fig. 19 – Pedestal back plate fasteners

Remove the highlighted pedestal back plate fasteners (M5 Allen Head screws, Qty 14)

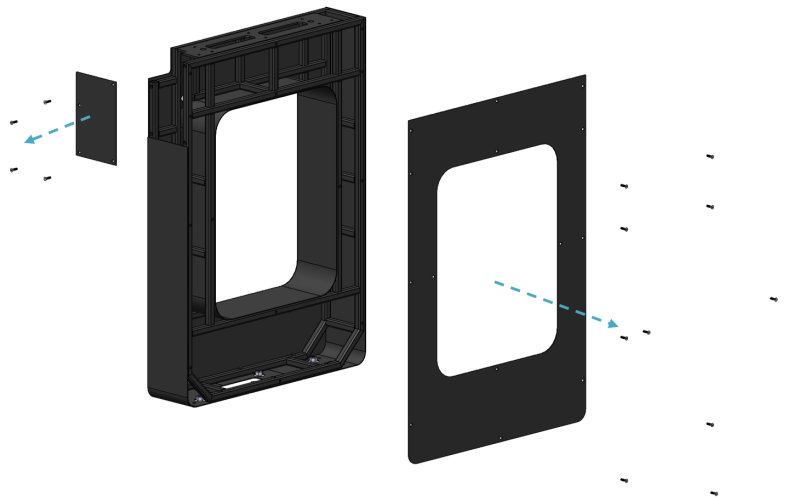

Fig. 20 – Remove pedestal back plate

Remove the pedestal back plate from the pedestal.

### 5.3.3 Attaching Pedestal to Anchor Plate

Now you are ready to install the Pedestal Unit. Carefully place the Pedestal Unit over the Anchor Plate, conduit, and any wires.

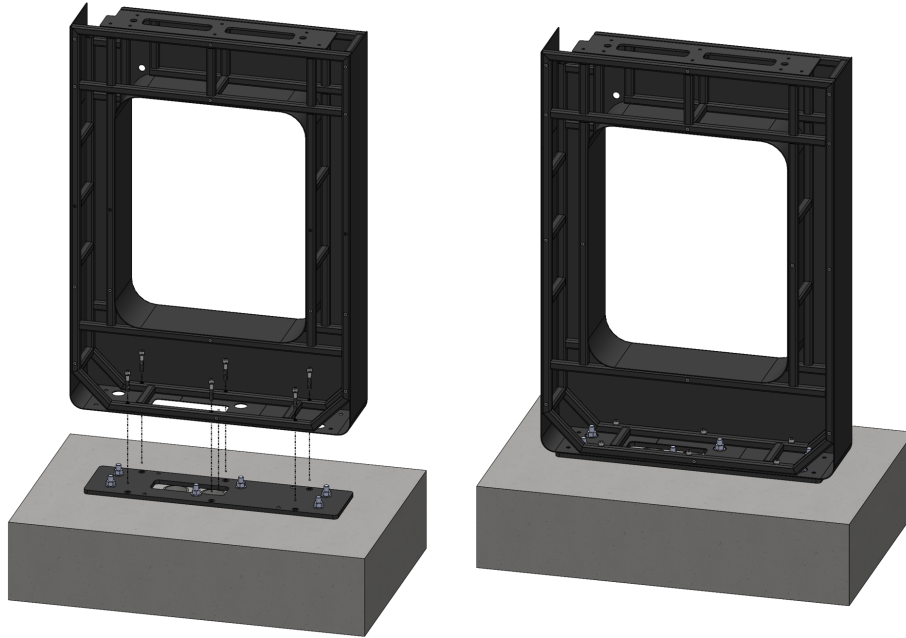

Fig. 21 – Attaching Pedestal to Anchor Plate

- Place the Pedestal Unit on the Anchor Plate aligning with the J-bolts.
- Ensure that the electric wires can be easily accessed inside pedestal structure to Head Unit.
- Ensure that at least 54" of wire extends out of the conduit.

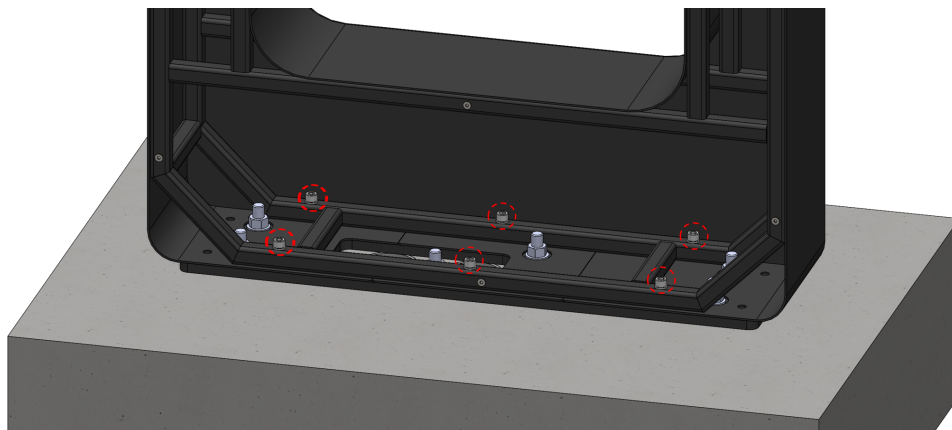

Fig. 22 – Pedestal Anchor Bolts

Attach pedestal to anchor plate using (6) 5/16" x 1 3/4" Socket Cap Screws and spring washers (torque 10-12Nm).

### 5.3.4 Holster Assembly

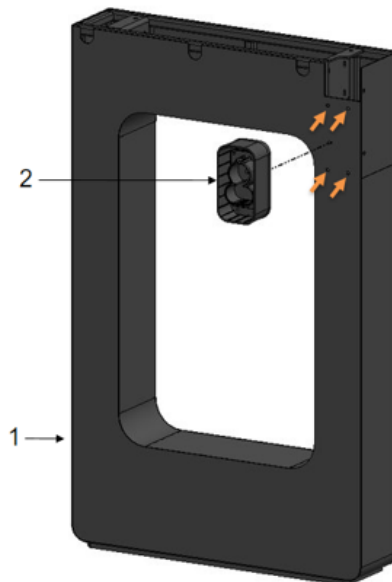

Fig. 23 – Holster Assembly

Affix holster assembly to the pedestal using (4) M6x30mm screws and Spring washers.

1. Pedestal
2. Holster Assembly

### 5.3.5 Head Unit Installation on Pedestal

Follow the diagram below for installing the head unit.

- **CAUTION** While mounting the head unit to the pedestal proper alignment should be ensured.

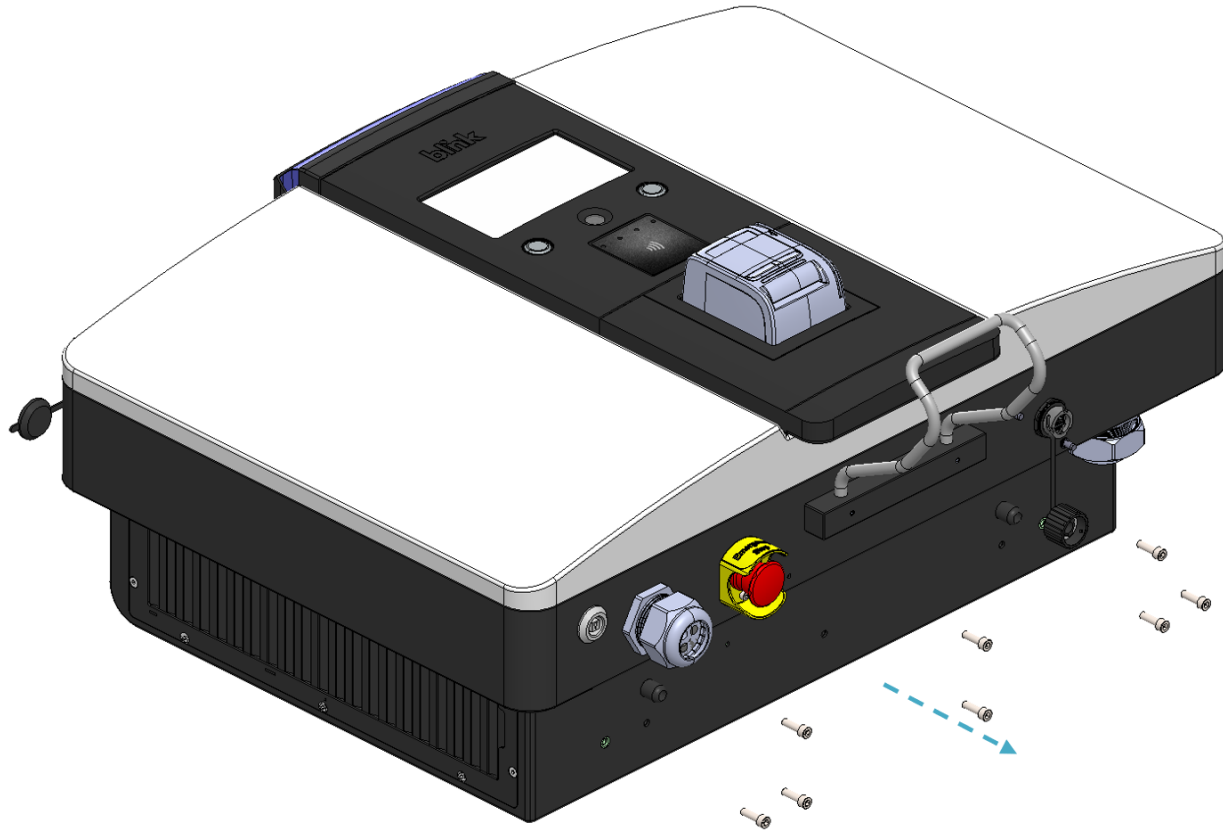

Fig. 24 – Head Unit mounting bolts

After unwrapping the Head unit take off the above **Red** highlighted 8x M6 Allen Head Metric Screws from the Head unit.



Fig. 25 – Mounting Head Unit on Pedestal

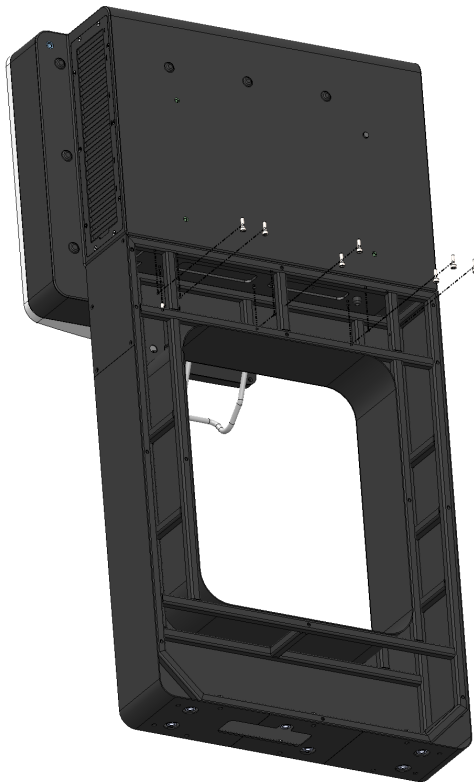

Fig. 26 – Securing Head Unit to Pedestal

Mount Head Unit above Pedestal assembly as shown in above images and attach to Pedestal using (8) M6 Allen Head Screws (Torque = 10-12 Nm) using a ratchet or angle screwdriver.



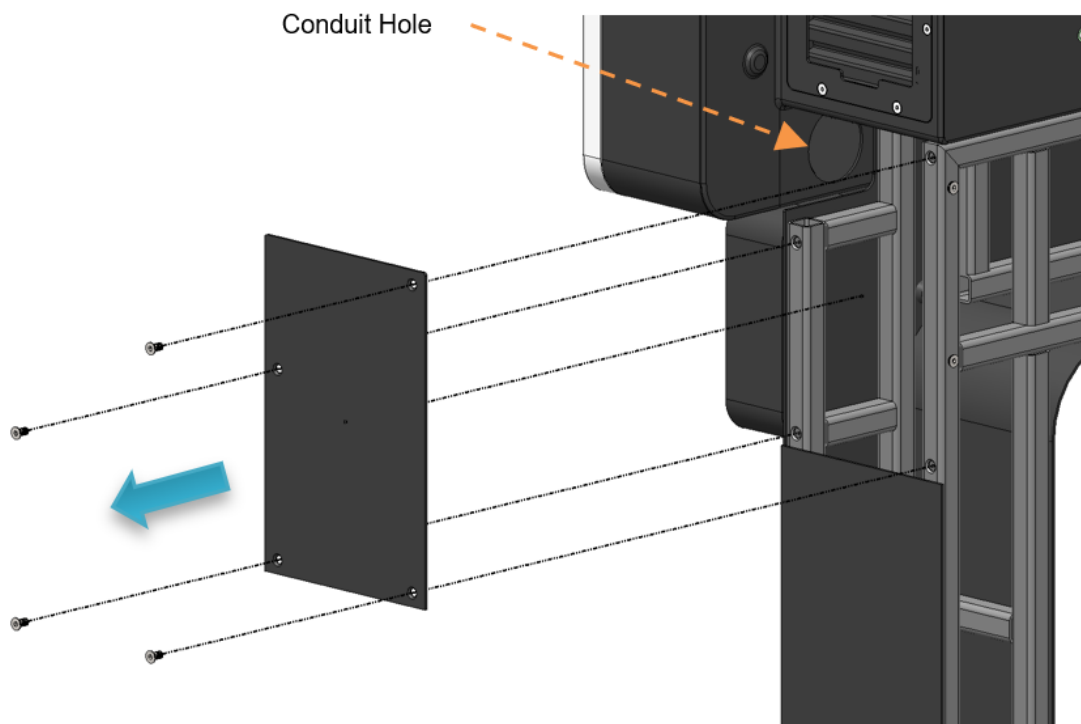

Fig. 27 – Side Access Panel and Conduit Hole location

Open the side access panel by removing (4) M5 CSK Screw to get access to the conduit hole. (Conduit hole size is 2", therefore 1 ½" conduit is recommended.)

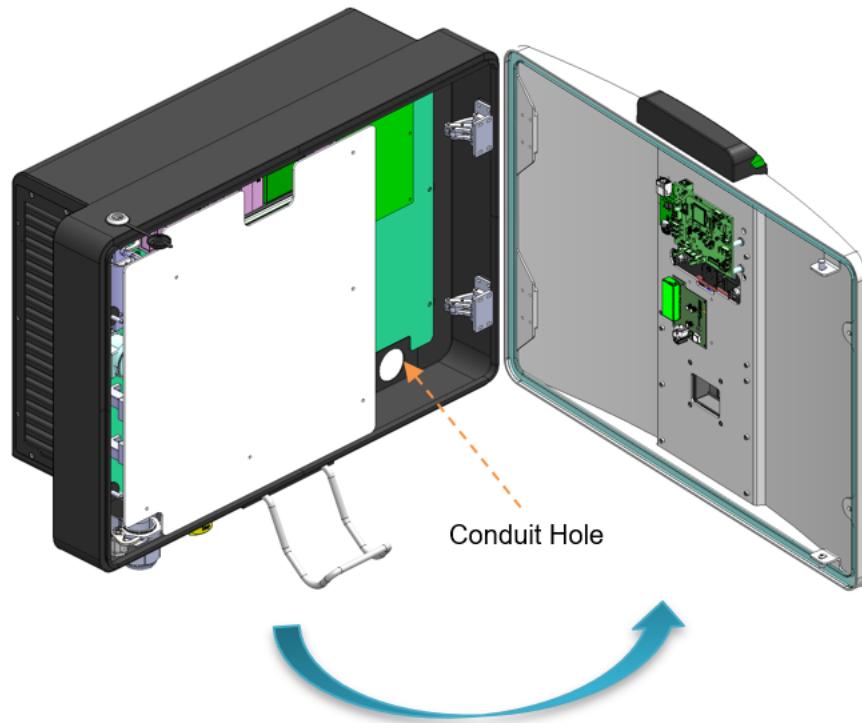

Fig. 28 – Open Front Enclosure

Unlock the Front Enclosure using 8mm Key. Fit the conduit to the Rear Enclosure

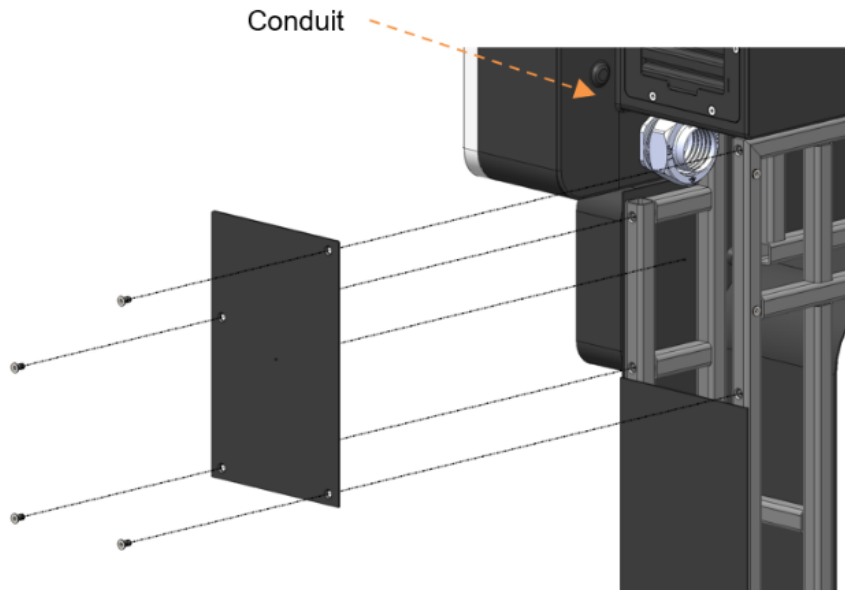

Fig. 29 – Attach conduit fitting

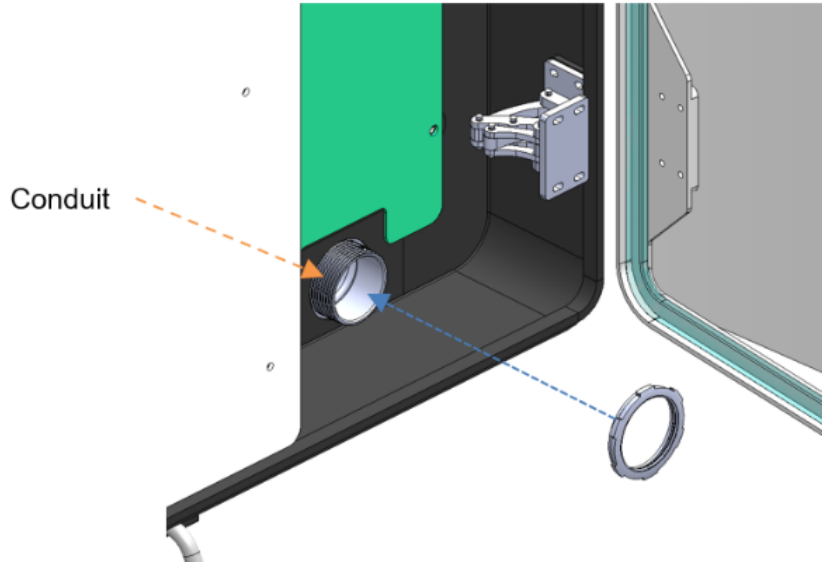

Fig. 30 – Attach conduit fitting

Affix conduit to the Rear Enclosure as shown in above image.

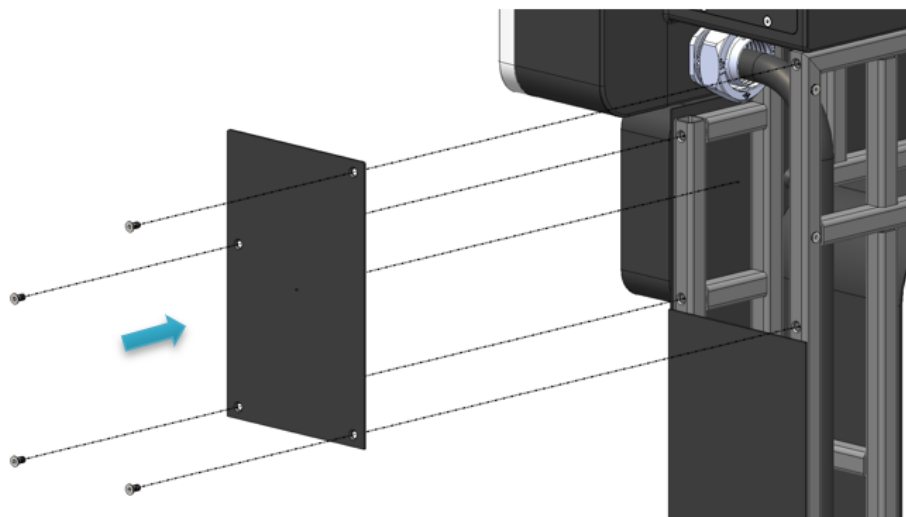

Fig. 31 – Input cable routing

Route the Input cable through the conduit and reattach the side access panel.

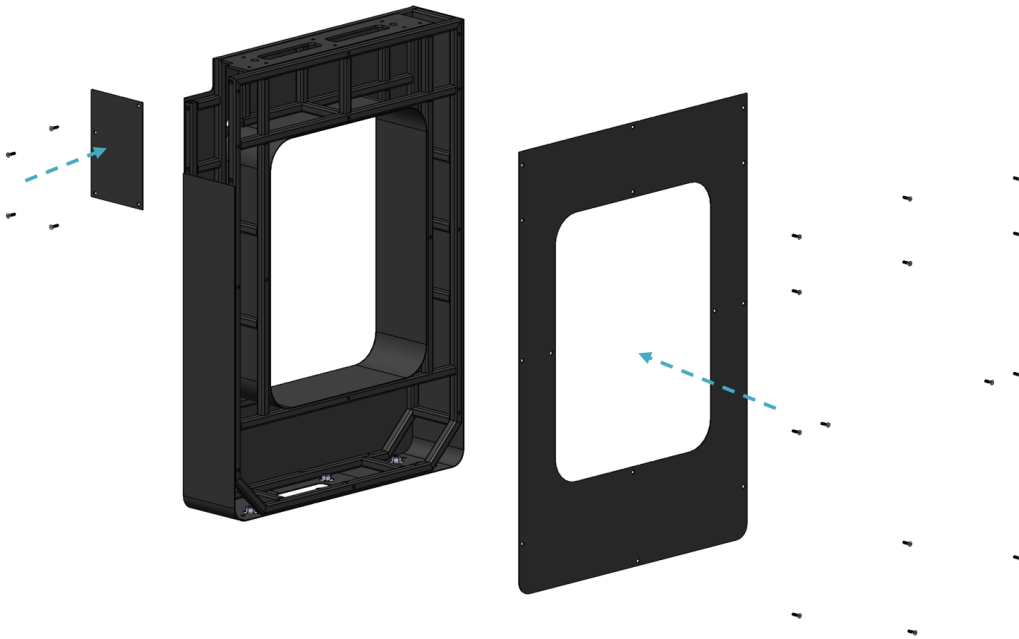

Fig. 32 – Replace pedestal back plate

Reattach the pedestal back plate to the pedestal.

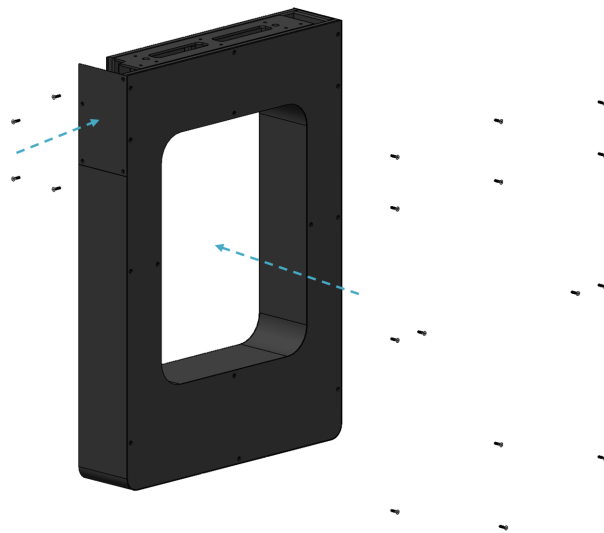

Fig. 33 – Reattach pedestal back plate.

Affix all the above highlighted (14) Pedestal Back plate fasteners by using M5 Allen Head CSK Screws (Torque = 5-6 Nm)

### 5.3.6 Final Installation with Pedestal Mount

Assemble the complete charger as shown in the diagram below:



Fig. 34 – Final Assembly of S9 Device with Pedestal

**Proceed to section 5.5 (CONNECTING TO INPUT POWER) for instructions on connecting the AC input wiring.**

## 5.4 Installing Charger with Wall Mount

### 5.4.1 Wall Mount Installation

Follow the diagram below for installing the head unit with wall mount.

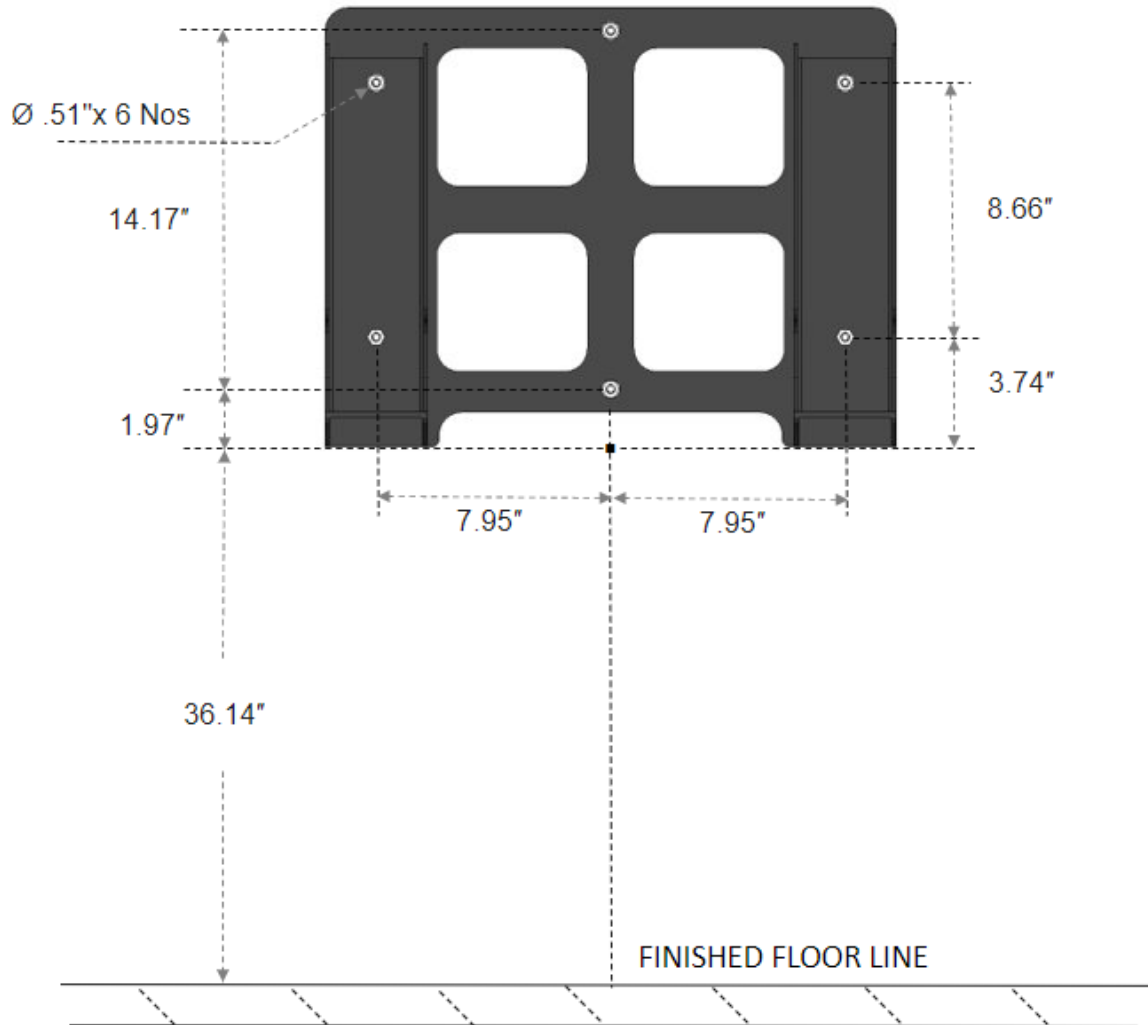

Fig. 35 – Wall Mount Dimensions

By using above template dimensions make Anchor holes (Ø.5" Inch) on wall to fix wall mount

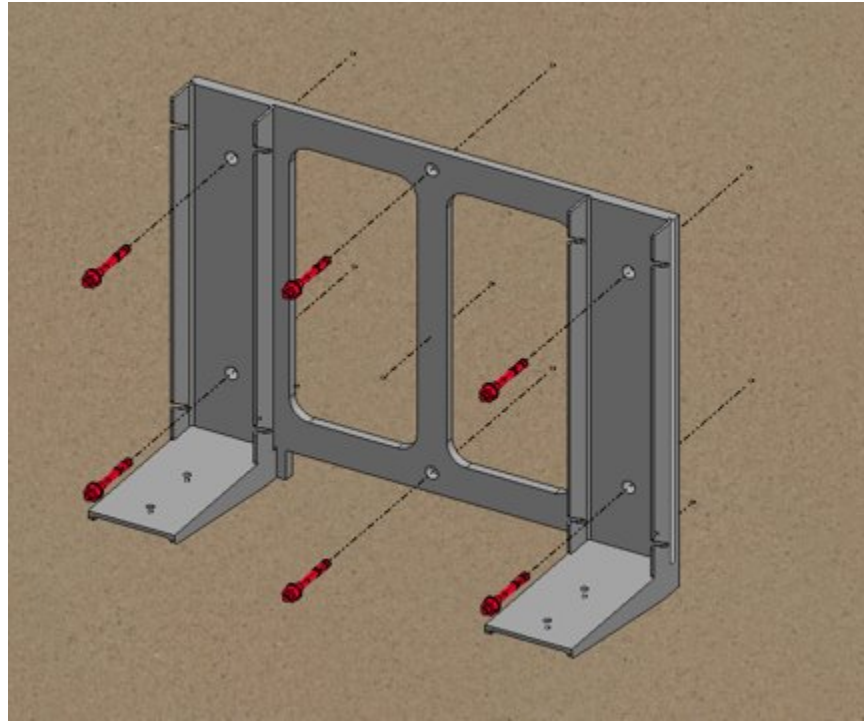

Fig. 36 – Wall mount anchor bolts

Installation Of Wall Mount Structure to Wall with Ø 1/2" inch Anchor Bolts – Qty 6

### 5.4.2 Head Unit Installation on Wall Mount

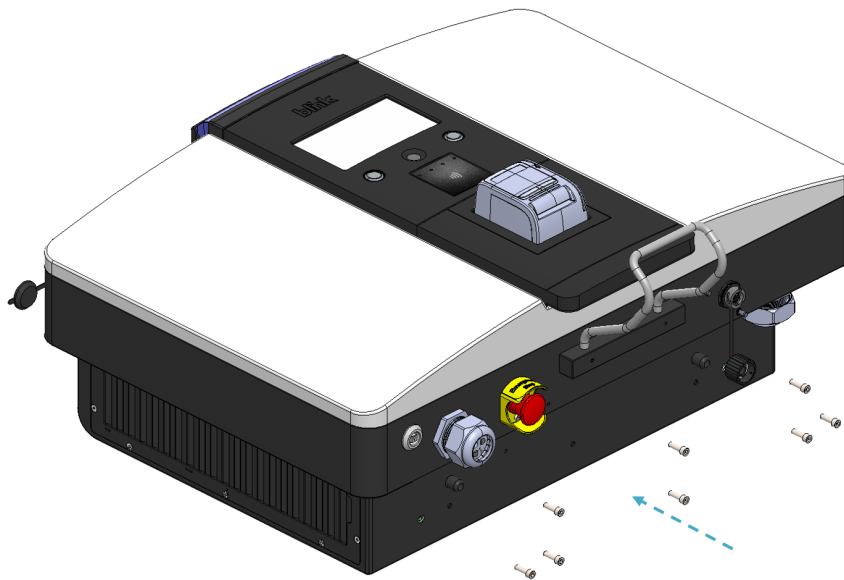

Fig. 37 – Head Unit mounting bolts

After unwrapping the Head unit take off the above **Red** highlighted 8x M6 Allen Head Metric Screws from the Head unit.

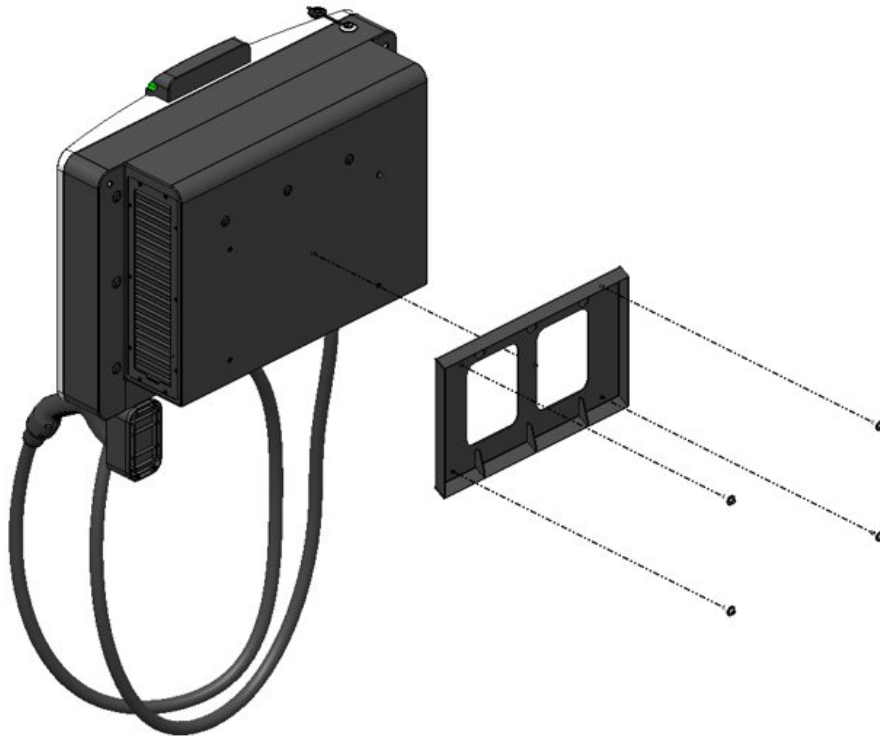

Fig. 38 – Attach Wall Bracket

Affix Wall Mount Bracket to the Head Unit Using M6x20mm Allen Screws with Plain Washer



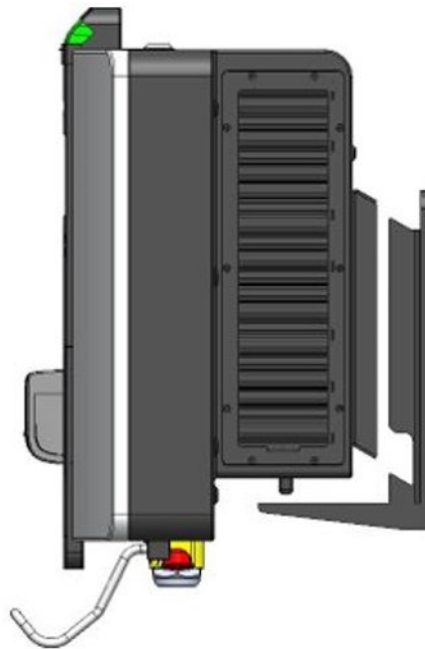

Fig. 39 – Hanging Head Unit to Wall Mount

Align/hang the head unit to the wall mount.

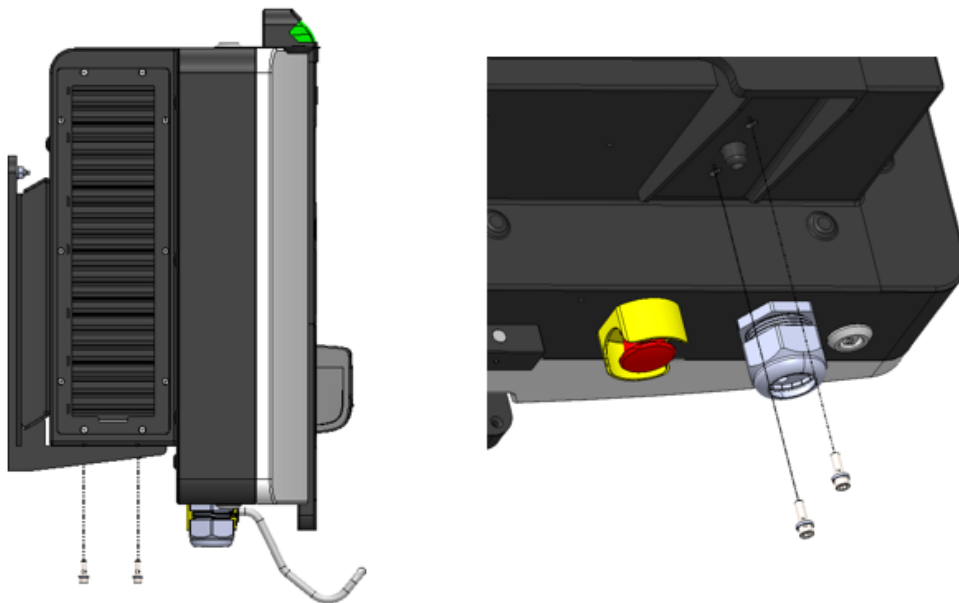

Fig. 40 – Securing Head Unit to Wall Mount

Lock the Head Unit after mounting it to the wall mount with (2) M6x30mm Allen cap screws + spring washer on output cable side as shown in above image (Torque 8-10Nm).

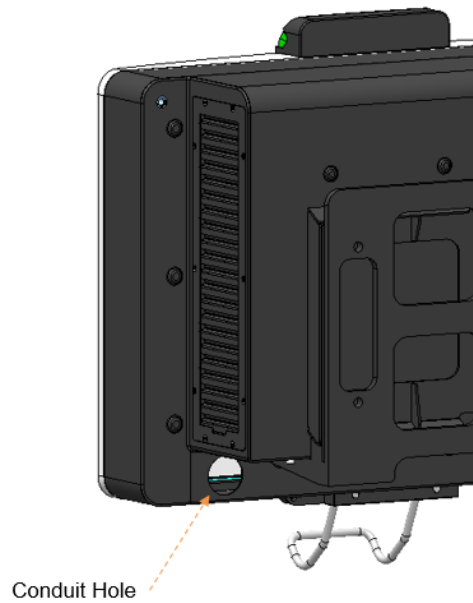

Fig. 41 – Conduit hole location

Locate conduit hole in the rear of the enclosure (Conduit hole size is 2", therefore 1 ½" conduit is recommended).

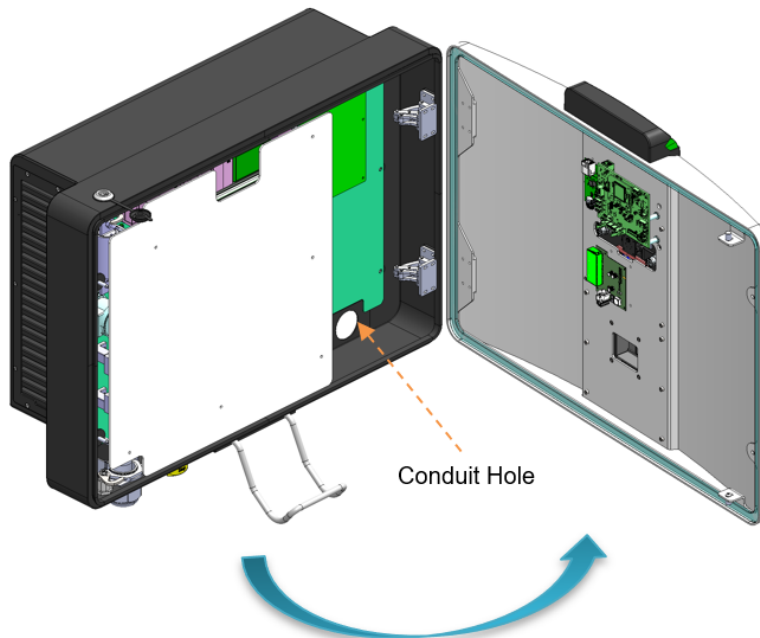

Fig. 42 – Open Front Enclosure

Unlock the Front Enclosure using provided 8mm Key. Fit the conduit to the Rear Enclosure

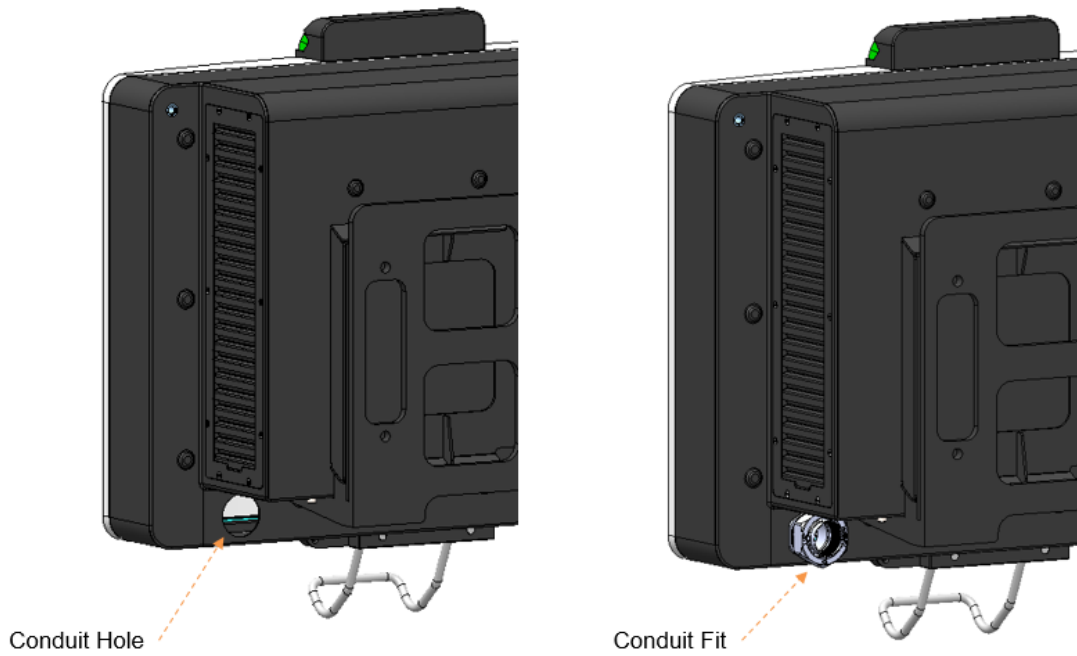

Fig. 43 – Attach conduit fitting

Affix conduit to the Rear Enclosure and route the input cable through the conduit. Ensure at least 18" of wire extends out of the conduit.

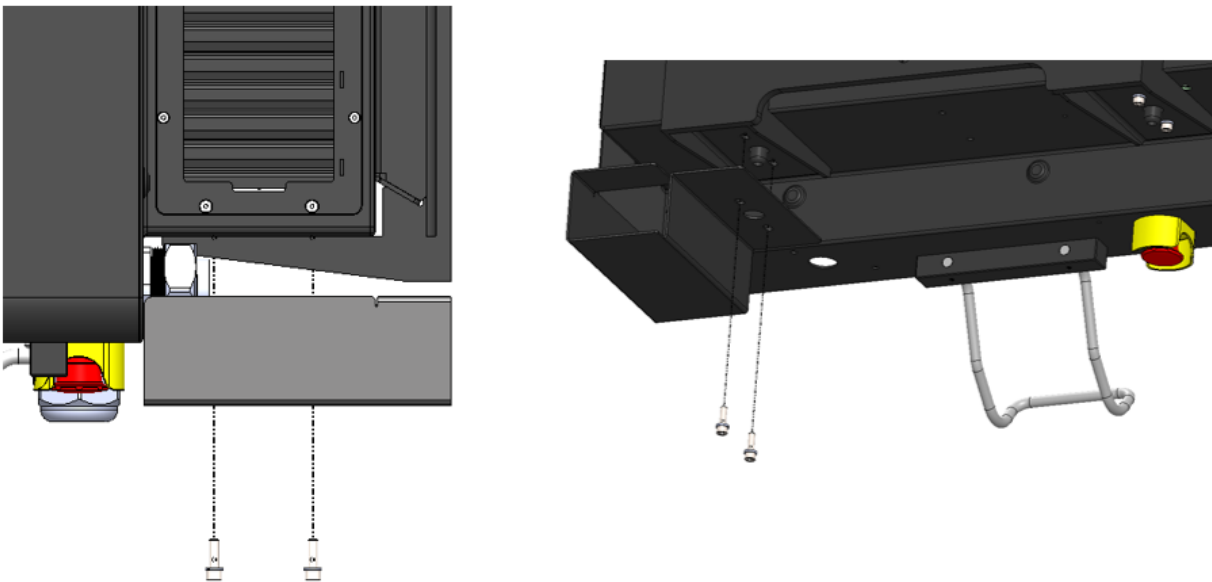

Fig. 44 – Attach Conduit Cover

After attaching the conduit, install the conduit cover using 2x M6x30mm Allen cap screws with spring washer (Torque 8-10Nm).

### 5.4.3 Final Installation with Wall Mount

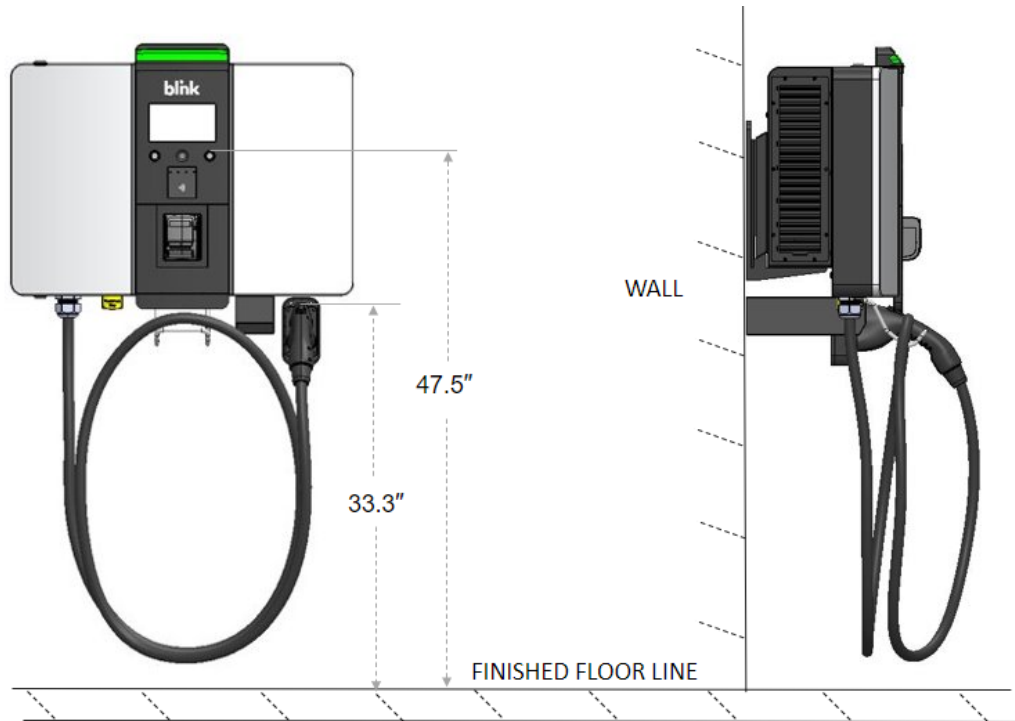

Fig. 45 – Charger with Wall Mount Dimensions

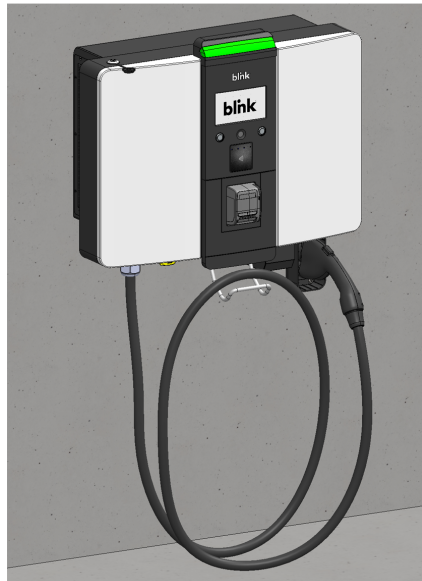

Fig. 46 – Final Assembly with Wall Mount

**Proceed to Section 5.5 (CONNECTING TO INPUT POWER) for instructions on connecting the AC input wiring**

### **5.5 Connecting Input Power**

Follow the diagram below for connecting the charger to 3-Phase AC input power.

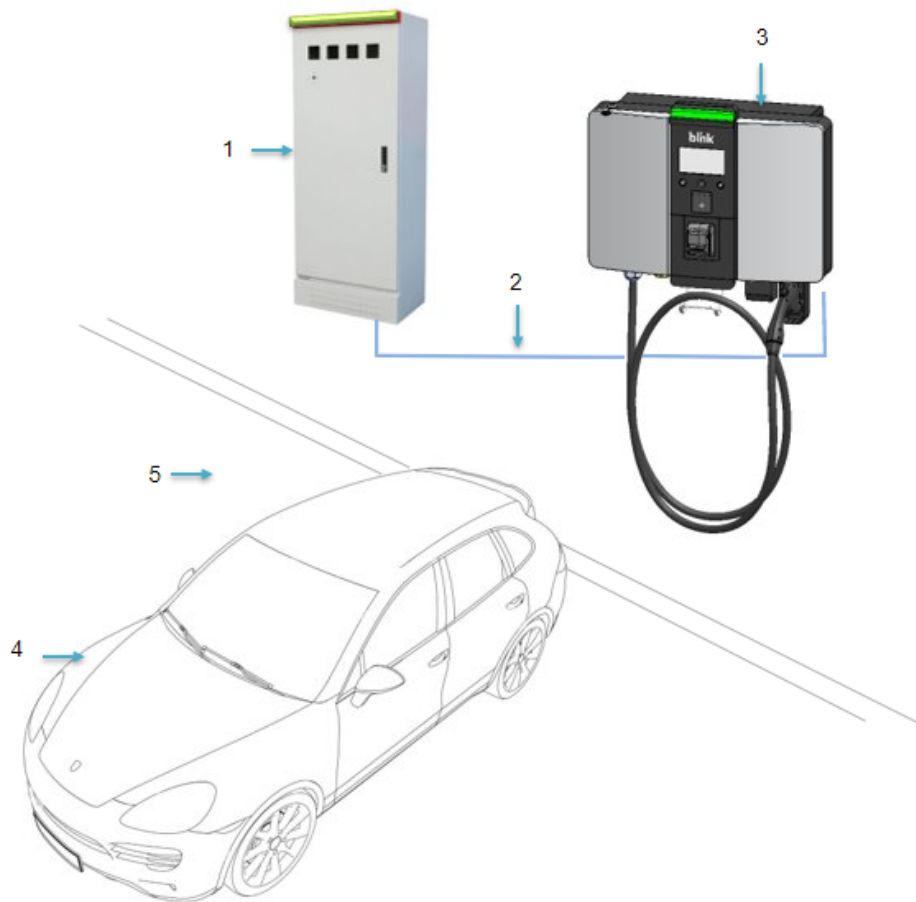

Fig. 47 – Input Power Diagram

1. 277/480V Circuit breaker panel
2. Power Input cable in conduit (3P + N + PE)
3. S9 DC30 Charger
4. Electric vehicle
5. Parking space for charging

### 5.5.1 Connecting to Ac Input Power

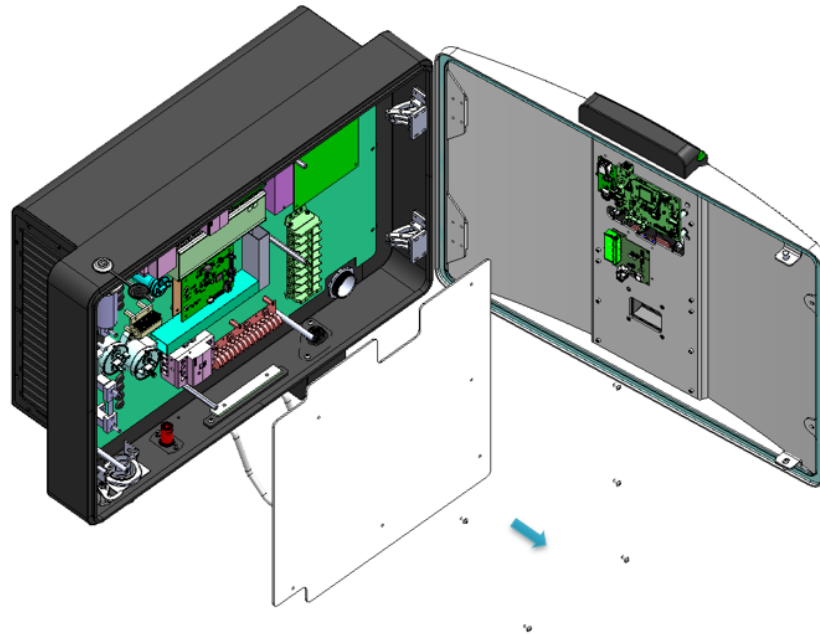

Fig. 48 – Remove plexiglass shield

- Assemble Ring Terminal connectors and supplied heat shrink tubing (Cut about 30 mm) on all AC input wires (6 AWG M6 connectors for 3P + N, 6 AWG M5 connector for Ground/PE)
- Insert (3P + N) input wires through the provided ferrite core. Secure the ferrite core using the provided cable tie(s).
- Remove the plastic cover from the AC input wiring terminal block. Connect (3P + N) wires to the corresponding terminals on the terminal block (torque = 3 Nm). Replace the plastic cover.

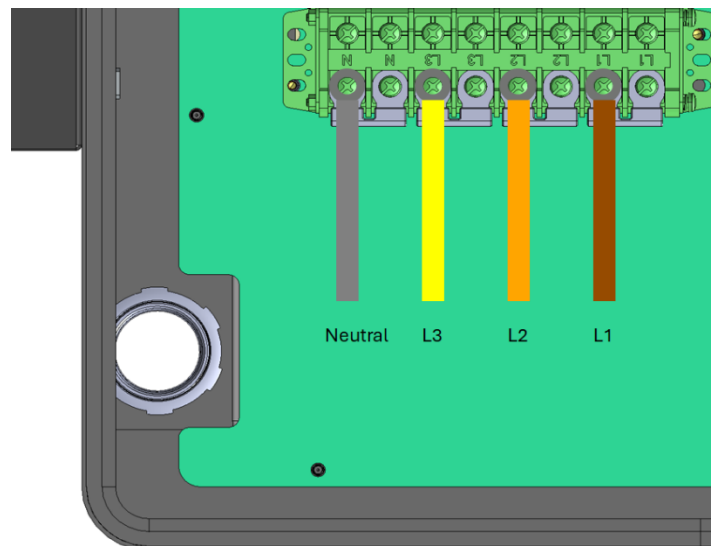

Fig. 49 – AC Input wiring terminals

Remove the large plexiglass shield (6x M4 screws). Connect the Ground/PE wire to the Ground Bus (torque = 4 Nm). Replace the plexiglass shield.



Fig. 50 – Input Ground wire connection

Close the Front Enclosure and lock using the provided 8mm key.

## 6. COMMISSIONING INSTRUCTIONS

### 6.1 Commissioning Precautions

- ❑ **⚠ WARNING** Please ensure the unit is properly installed in accordance with the installation instructions before it is commissioned.

### 6.2 Pre-Commissioning

The following steps are typically performed by the production team at the factory.

#### 6.2.1 Preparation

- ❑ The URL and Charger ID is programmed to the charger at the factory.

#### 6.2.1 Enrollment

- ❑ Station sends its first request in Boot Notification message to server with following parameters.



<b>Serial Number</b>	BAExxxxxx
<b>Volts</b>	277
<b>Amperage</b>	38
<b>Organization</b>	Blink Pending Installs
<b>Access Type</b>	Open

Table 6 – Enrollment parameters

### 6.2.2 Configuration

- If required, the program manager modifies the configuration parameters – Serial #, Volts and Amperage, and Access type. The program manager also assigns the station to the designated organization.

<b>Serial Number</b>	BAExxxxxx
<b>Volts</b>	277
<b>Amperage</b>	38
<b>Organization</b>	“New Organization Name”
<b>Access Type</b>	Open

Table 7 – Configuration parameters

### 6.3 Activation

Activation is typically done by the customer success team.

- Site hosts fill out a form on pricing plan etc.
- Site / Org admin or program manager configures station with following information based on the information filled out.

<b>Serial Number</b>	BAExxxxxx
<b>Volts</b>	277
<b>Amperage</b>	38
<b>Organization</b>	New Organization Name

<b>Access Type</b>	Open / Member Only/ Member & Public
<b>Pricing</b>	Pricing Plan
<b>Location</b>	Location name & address
<b>Name</b>	Station Name

Table 8 – Activation parameters

## 6.4 Powering The Charger

The following steps must be performed prior to initial power-up:

**▲ CAUTION** Be Aware of High Voltage!

### 6.4.1 Checklist Prior To Initial Power-Up

1. Verify DCFC AC source breaker and any AC source isolation disconnects are OFF and locked out.
2. Verify DCFC is not powered on at input terminals.
3. Verify input connections (L1, L2, L3, N, and Ground/PE) are properly connected and secured.
4. Check for any damage on the DCFC exterior cover and metal frame.
5. Verify the airflow of the DCFC is unobstructed.
6. Verify there are no short circuits after the AC source breaker or AC source isolation disconnect by measuring the resistance on DCFC's AC input terminals.
  - a. between phases should be  $> 0.5M\Omega$
  - b. between phases and ground should be infinite
7. Verify continuity between Neutral and PE
8. Measure Resistance between the DC+ and DC- on DCFC output EV connector(s)  $> 1M\Omega$
9. Measure Resistance between DC+ and PE, and DC- and PE on DCFC output EV connector(s)  $> 1M\Omega$
10. Verify all flash covers are installed and DCFC is closed securely.
11. Verify all AC source equipment covers are installed and equipment is closed securely.

### 6.4.2 Initial Power-Up Sequence

1. Remove Lockout equipment from AC source breaker or AC source isolation disconnect.
2. Energize DCFC at source breaker or isolation disconnect.
3. Open DCFC Front Enclosure
4. Verify voltage is 277V from each phase to PE (+/- 10%)
5. Verify voltage is 277V from each phase to neutral (+/- 10%)
6. Verify voltage is 0V from neutral to PE
7. Verify voltage is 480V between each phase (+/- 10%)
8. Close and lock DCFC Front Enclosure

### 6.4.3 System Initialization

- When the charger is powered on, it starts with the “Blink” Initializing page.
- The image below will be displayed on the screen after powering on and when the system is being initialized (Fig. 51).
- The initializing process will take around 2 minutes.



Fig. 51 – Bootup screen

### 6.4.4 Idle State

- After the system is initialized, the screen will cycle through its idle screens as shown below.
- There is a total of (5) five idle pages in the rotating cycle as shown below (Fig. 52 – 56)

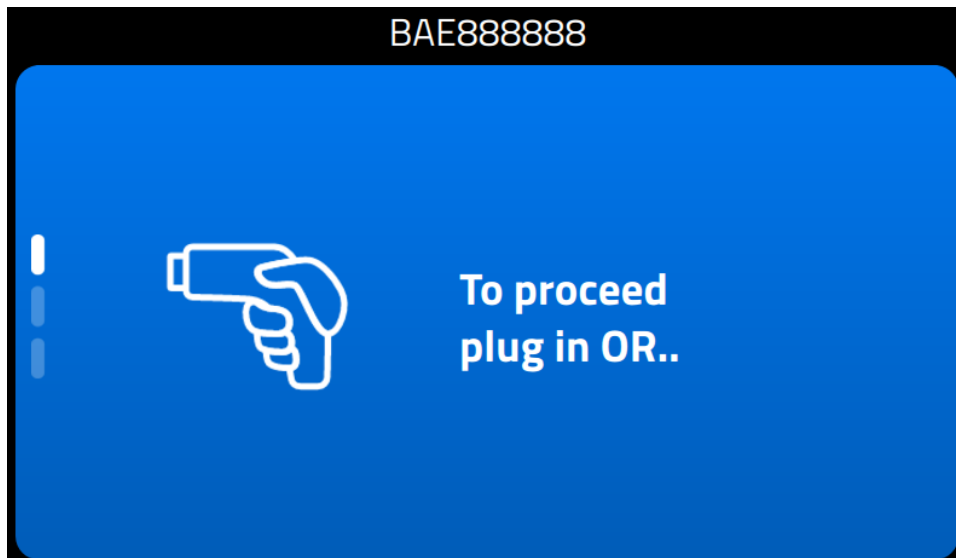

Fig. 52 – Idle screen plugin request

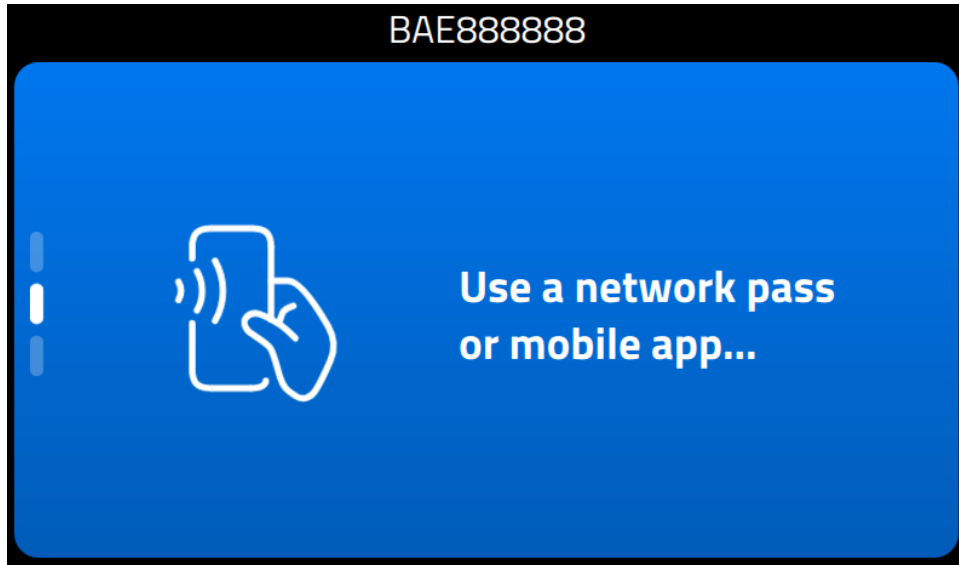

Fig. 53 – Idle screen authorization request

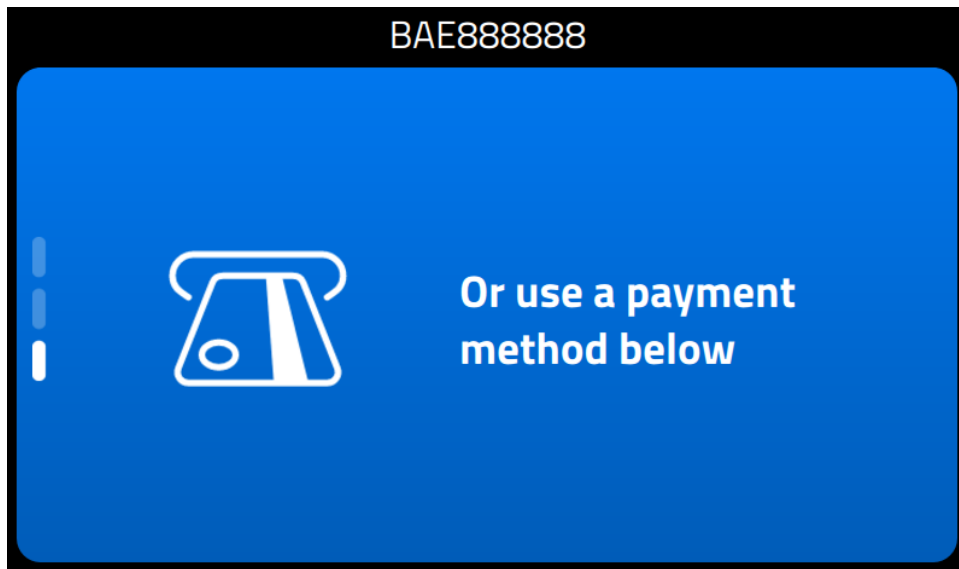

Fig. 54 – Idle screen authorization request

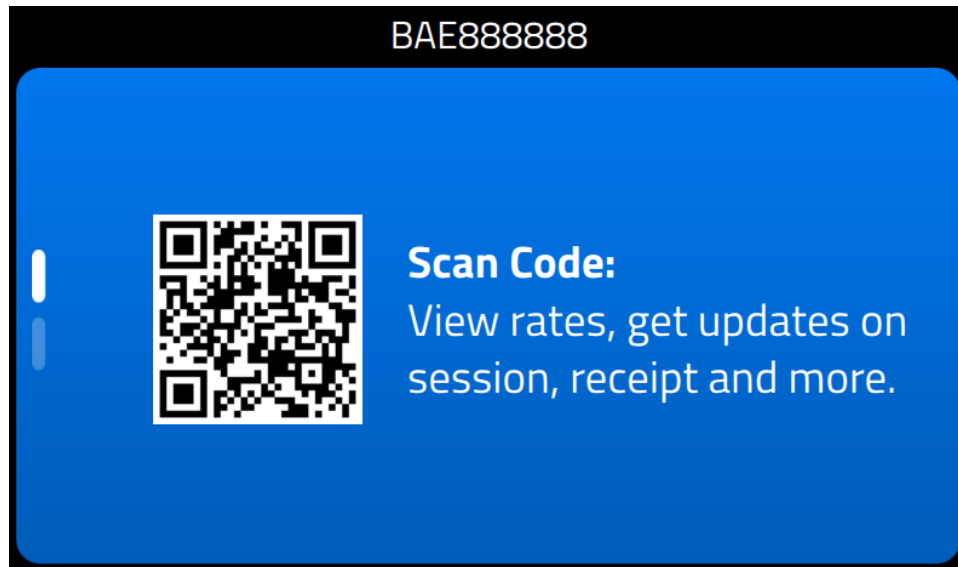

Fig. 55 – Idle screen QR code

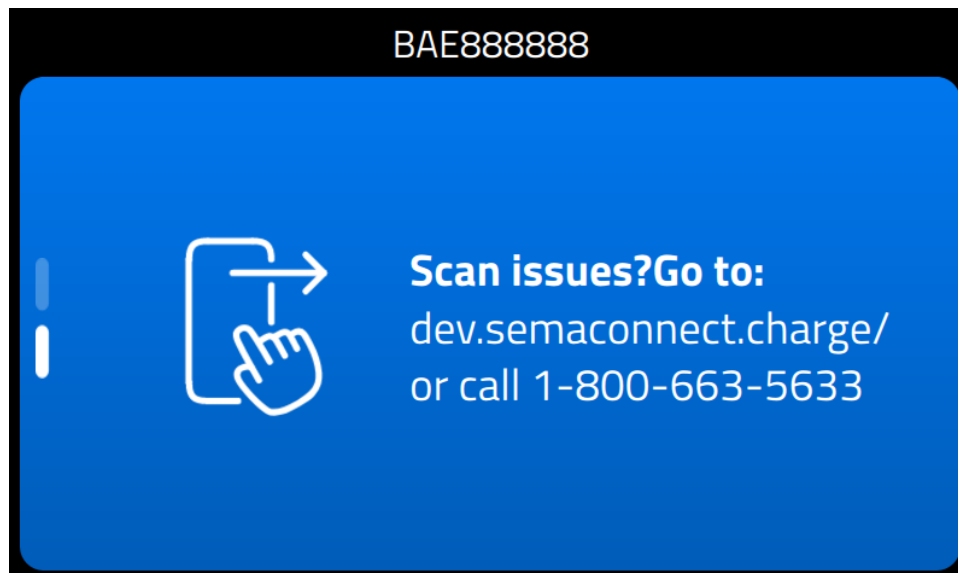

Fig. 56 – Idle screen customer service contact

## 7. OPERATING INSTRUCTIONS

Read all the instructions before operating this product.

### 7.1 Operating Precautions

- **⚠ WARNING** Please make sure that the unit is properly commissioned in accordance with the commissioning instructions before it is used.
- **⚠ WARNING** Do not use this product if the enclosure or charging connector are broken or

- open or if it is damaged or been tampered with.
- **⚠ WARNING** Do not use the charger if there is water intruding into the charger.
- **⚠ WARNING** Do not use this product if the power cable or charging cable have any damage.
- **⚠ WARNING** Do not put any tool, material, finger or other body part into the charging connector or EV connector.
- **⚠ CAUTION** The product should be inspected by a qualified installer prior to initial use. Under no circumstances will compliance with the information in this manual relieve the user of his /her responsibilities to comply with all applicable codes and safety standards.
- **NOTICE** When using the DC Fast Charger please handle it properly. Do not strike or scrape the cabinet or touch screen.

## 7.2 Operating the Charger

Following are the necessary steps for the operation of the charger.

### 7.2.1 User Authorization

- From the idle pages the user can authorize the system for charging.
- Authorization of the station can be done via RFID card, mobile app, mobile number, QR code (when using the Blink app) or credit card  
Note: Optional credit card reader is required to use credit card.
- Once authorized, the user can plug in the charging cable to the vehicle.  
Note: For Tesla drivers, please use the Tesla CCS1 adapter.
- Fig. 57 demonstrates a system that has been plugged in and waiting for authorization.

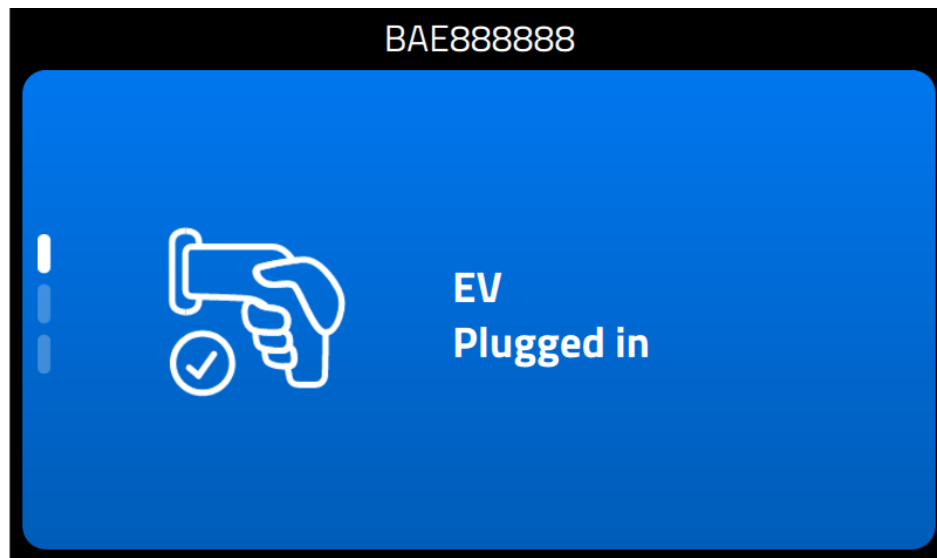

Fig. 57 – EV Plugged in

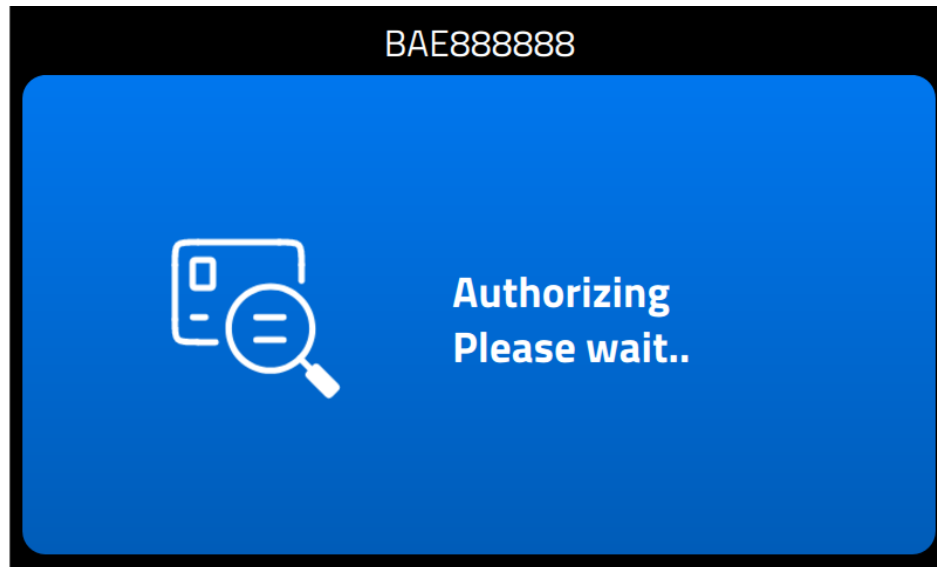

Fig. 58 – Authorizing

### 7.3 System Charging

- ❑ Once the station has been authorized and plugged in, the display will show the charging page.
- ❑ The charging page will display the current rate, time connected, kilowatt-hours consumed, battery state-of-charge (SoC), and current wattage transfer rate.
- ❑ The display updates as the session continues.
- ❑ Fig. 59 shows an active charging session.

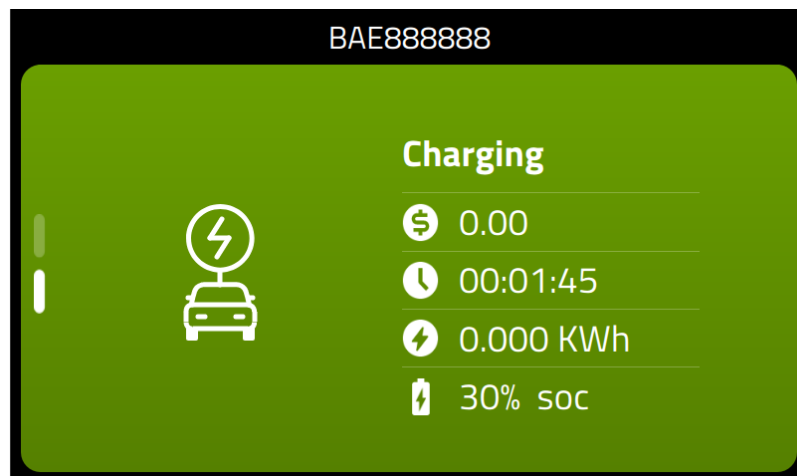

Fig. 59 – Active Charging display

### 7.3.1 Charging Completed

- Once the charging session is completed, the display shall update to show the total cost of the charging along with the current rate, total time, total kilowatt hours consumed and a thank you message will be visible on the charging complete page
- Fig. 60 shows a charge completed page

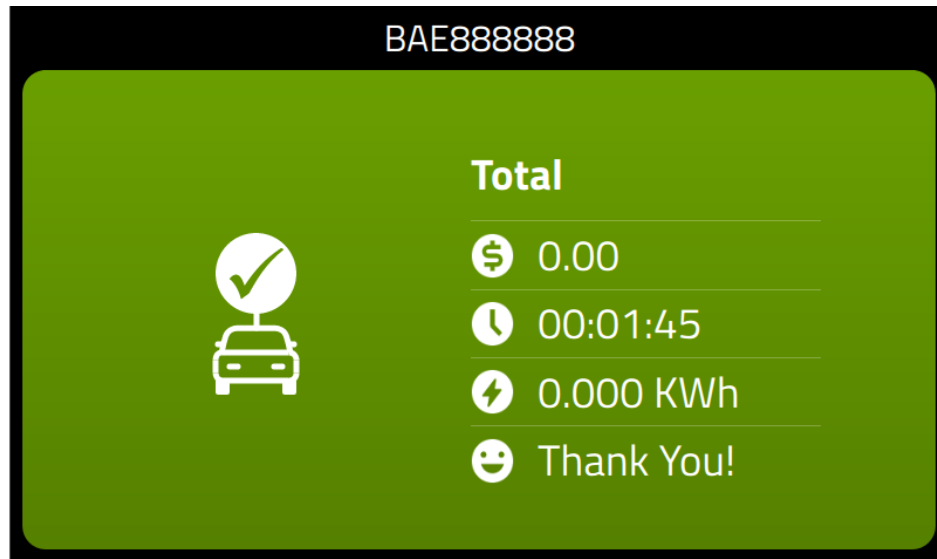

Fig. 60 – Charge Complete

- **NOTICE** Please make sure the charging connector is returned to the holder of the charging connector after charging to prevent damage.

### 7.4 Operation Status

The following table provides the LED indicator and the corresponding status:

Status	LED Indicator	Description
Standby	Solid Green	When the station is in a standby state
Authenticating	Breathing Aqua	When the station is authorizing the charging session
Charging	Solid Blue	During a charging session
Fault	Solid Red	Whenever an error is encountered

Table 9 – Operation Status Indicators



## 7.5 Use Of Emergency Button

- **NOTICE** For emergency, push the Emergency Stop Button to stop charging immediately.



Fig. 61 – Emergency Stop Button location

## 7.6 Customer Support

Please contact customer support

- If the enclosure or screen is broken, cracked, opened, or shows any other indication of damage.
- If there is damage to the charging connector, charging cable or holder of the charging connector.
- If there is water intruding into the DC Fast Charger, please cut off the power source immediately and contact Blink customer success team for repair.
- Please record the status code number (if any) on the LCD monitor before calling customer support.

The following is the contact information for customer support.

- **Customer Support: 888-998-2546 or [customerservice@blinkcharging.com](mailto:customerservice@blinkcharging.com)**

## 8. MAINTENANCE INSTRUCTIONS

### 8.1 Maintenance Precautions

- **⚠ WARNING** Maintenance of the DC Fast Charger shall be conducted only by a qualified technician.
- **⚠ CAUTION** Turn OFF power at the circuit breaker and any external disconnect switches

before working on the equipment or removing any component. Do not remove circuit protective devices or any other component until the power is turned OFF. Turn OFF the main breaker and auxiliary breaker before opening the front door of the DC Fast Charger for any maintenance work.

- ❑ **⚠ CAUTION** Disconnect electrical power to the DC Fast Charger before any maintenance work to ensure it is separated from the supply of AC mains. Failure to do so may cause physical injury or damage to the electrical system and charging unit.
- ❑ **⚠ CAUTION** Each of the capacitors in this device have a high voltage for a time after shutting off the input power supply, allow 1 minute after powering down before servicing internal components.

## 8.2 Preventive Maintenance

### 8.2.1 Checklist Before, During and After Maintenance

#### Before Maintenance

1. Ensure the LCD display and LEDs are lit and functioning normally.
2. Check for any abnormal sounds or odors from the unit.
3. Ensure that there is no external corrosion or other damage to the charger enclosure, display, charging cable, or CCS connector.

#### During Maintenance

1. Check for corrosion of internal mechanical components and wire connections.
2. Ensure that there are no foreign objects/particles present in the Charger.
3. Check for excessive dust/debris in the air filters. The filters can be replaced as described in section 8.2.3.
4. Ensure that there are no dangling or unconnected wires present in the Charger.
5. Check for any water presence in the charger and contact customer support in case of excess water presence in the Charger.
4. Ensure that all the screws are assembled before closing the Charger.

#### After Maintenance

1. Prior to closing the charger, check the Ground/Earth resistance and make sure it is within acceptable limits, as per the Electric Code.
2. Power ON the external circuit breaker(s) and ensure AC input voltages are within acceptable limits.
3. After closing the charger, ensure the LCD display and LEDs are lit and functioning normally.

#### Cleaning

- ❑ **NOTICE** The housing was made of welding process and surface painting. Clean the DC fast Charger at least three times a year and keep the exterior clean.
- ❑ Clean the outside of the cabinet with a damp cloth or wet cotton towel, only use low-pressure tap water and cleaning agents with PH level between 6 to 8.
- ❑ Do not apply high-pressure water jets.
- ❑ Do not use cleaning agents with abrasive components and do not use abrasive tools. Improper

cleaning agents might spoil coating, painting, surface, brightness, and durability of all exterior parts.

### 8.2.2 Replacing Filter

- **⚠ WARNING** Moving part – Risk of Injury. Make sure the fans are turned off and the station is not used during maintenance. Moving fans can be dangerous and cause injuries.
- **⚠ CAUTION** Careful while opening & closing the front enclosure near gasketing area.
- **⚠ CAUTION** Vent assembly mounting & dismounting should be carefully handled due to ingress protection.
- **NOTICE** To ensure the DC Fast Charger works properly, replace the ventilation filter every six to eight months (depending on environmental conditions).
- Filters can be replaced, and accessibility as described below. The filters are inside the filter cartridge. Contact Blink support for spare filter parts.

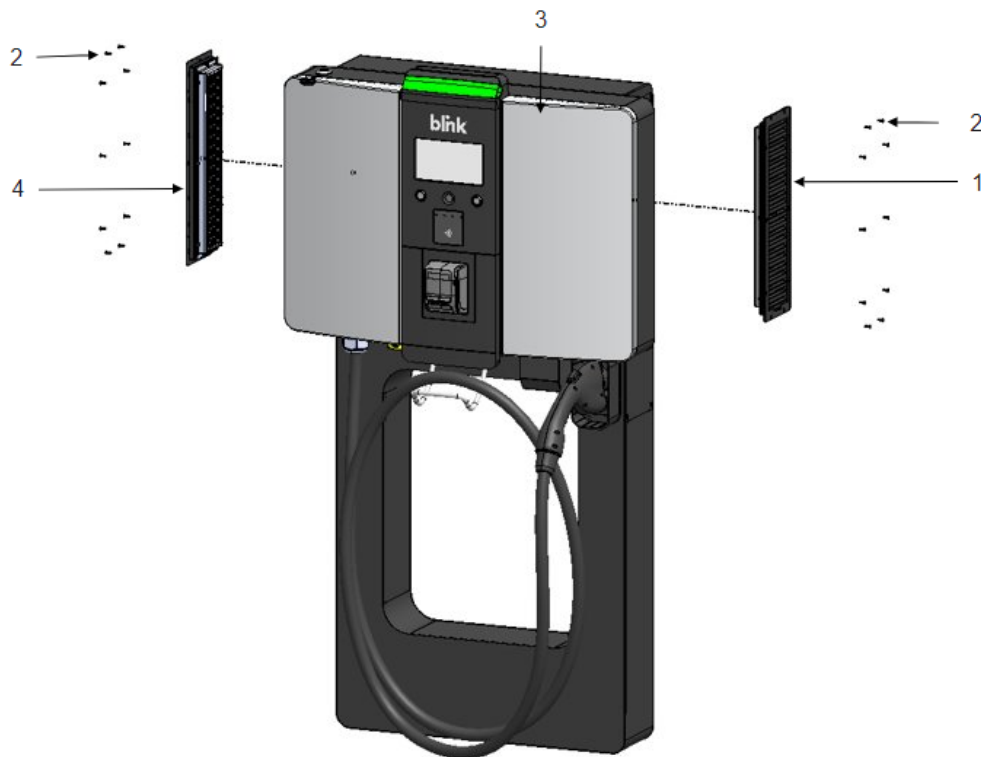

Fig. 62 – Air vent assemblies

1. Vent Assembly Right
2. M4x12mm (about 0.47 inch) CSK Socket Head Screws (Qty 20)
3. Head Unit
4. Vent Assembly Left

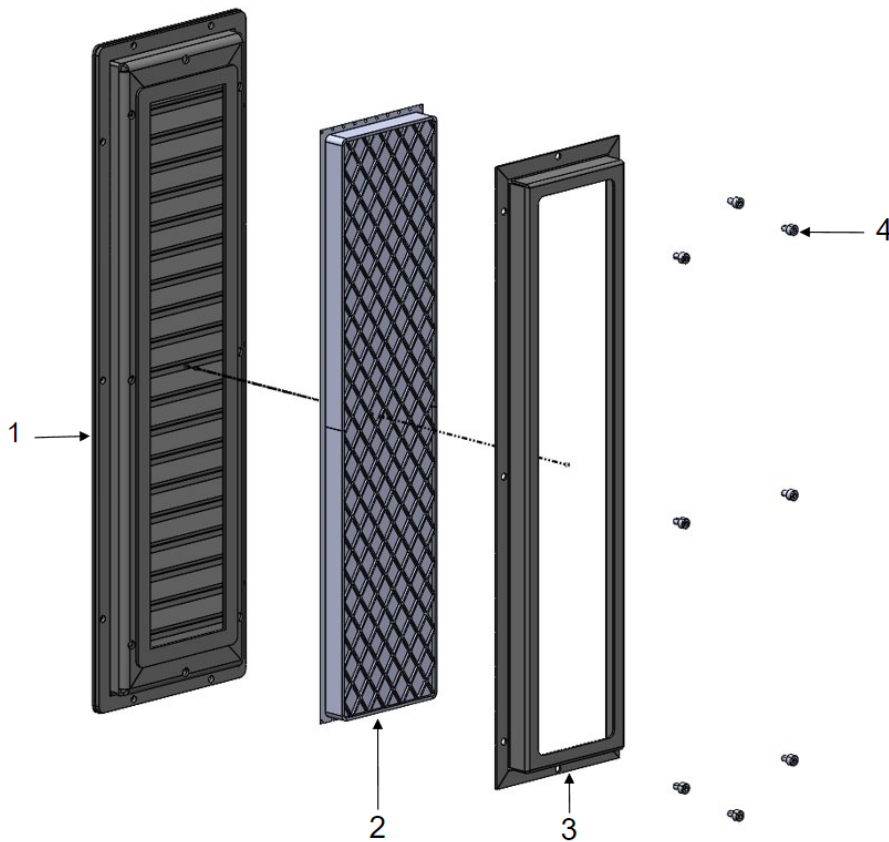

Fig. 63 – Air filter assembly

1. Vent assembly
2. Air filter
3. Air filter cover
4. M4x6mm (about 0.24 in) Allen head screws (Qty 8)

### 8.3 Troubleshooting

- If there are any issues with the system, a status message will be displayed on the screen. The following screen shows an error code as an example.



Fig. 64 – Error status message

- Contact Blink customer success team with status codes for troubleshooting any issue

## 8.4 Error Message or Codes

The following table provides the list of commonly used error message codes displayed on the charger.

Error Message or Code	Description
Emergency button pressed, release to resume charging	Emergency button is pressed
Ground isolation error	IMD error
Fault occurred during normal operation or self-test	AC Contactor error
Communication module or link connection fault	SLAC error
There was a problem operating pre-charge contactor	Pre-charge contactor error (DCFC)

There was a problem operating primary contactor	Primary Contactor error (DCFC)
Internal Temperature sensor fault	Temperature sensor error
Fault in Air cooling system	Aircooling system error
Error occurred during AC to DC conversion	Power module error
GF 0001	GFCI_FLAG_TRIP_EVENT
GF 0002	GFCI_FLAG_GROUND_TEST_FAIL
GF 0004	GFCI_FLAG_TRIP_EVENT_ON_CLOSURE
GF 0008	GFCI_FLAG_TRIP_EVENT_MAX_COUNT_EXCEEDED
GF 0010	GFCI_FLAG_RELAY_CLOSE_FAIL
GF 0040	GFCI_FLAG_RELAY_OPEN_FAIL
GF 0080	GFCI_FLAG_WELDED
GF 0200	GFCI_FLAG_CLOSE_RELAY
GF 0400	GFCI_FLAG_RELAY_IS_CLOSED
GF 0800	GFCI_FLAG_GROUND_CONNECTION_FAIL
GF 1000	GFCI_FLAG_GROUND_TEST_COMPLETED
J(STATE) 01	J1772_ERROR_NONE
J(STATE) 02	J1772_ERROR_VENTILATION_NOT_AVAILABLE

J(STATE) 04	J1772_ERROR_STATE_E
J(STATE) 08	J1772_ERROR_STATE_F
J(STATE) 10	J1772_ERROR_STATE_INVALID

Table 10 – Error code list

## 8.5 Limited Warranty

### 8.5.1 Warranty Policy

The Limited Product Warranty (“The Warranty”) applies to the Blink 9030 DCFC (Direct Current Fast Charge) charger (station) purchased from Blink or one of Blink’s authorized distributors or resellers. The Warranty shall cover the station from any manufacturer and/or workmanship defects for the period specified at the time of purchase. Upon verification of a valid warranty claim, Blink shall repair the station.

The following instances and events are not covered under the warranty policy (exclusions):

- Damage due to factors out of supplier’s control such as power surges, lightning, earthquake (i.e., “Acts of God”), etc.
- Damage due to negligence, failure to maintain the product, or any other event beyond Blink Charging’s reasonable control.
- Alteration and/or modification to the product without prior approval from with Blink Charging.
- Use of software, interfaces or parts not approved by Blink Charging.
- Any damage to the EV charging cord unless it is the result of manufacturing defects in the cord or connector assembly.
- Acts of vandalism.
- Abuse, physical damage, misapplication, or damages due to station usage not outlined in official Blink documentation.
- Installation or relocation of the station unless performed by a certified electrician or Blink approved technician.
- Improper site preparation or maintenance.
- Consumables such as door key, RFID card, air filter, fuse, cable, internal wires and connectors.

For additional information about the warranty policy, please refer to the official Blink Limited Warranty documentation or contact a Blink representative via the contact information provided in this document.